

6" Tall Rip Fence Extrusion For RIKON's 10-325 Bandsaw

MOUNTING THE FENCE ON THE CARRIER

1. Remove the current/old fence that is mounted on your machine. On the fence carrier bracket, loosen the two knobs that secure the carriage bolts to the fence, then slide the old fence off of the bolts.

The re-saw bar that was supplied on the 10-325 fence will not fit the new 6" tall fence, so it should also be removed and set aside.

NOTE: Refer to your bandsaw's original Operator's Manual for instructions on the proper steps to safely perform this operation on your particular machine model.

2. Install the new 6" Tall Rip Fence onto the bandsaw's fence carrier. The new fence has mounting channels in its design that duplicate the channels/tracks of the old fence. To attach the new fence on the 10-325 fence carrier bracket, simply slide the new fence onto the two carriage bolts and secure in position with the two knobs that were loosened in step 1.

ADJUSTING THE FENCE TO THE TABLE

Check that the fence is lying flat or parallel to the table surface. The gap between the table and the bottom of the fence should be equal along the whole length of the fence. The rear, bottom of the fence includes a Nylon Plate (Parts List #5) that helps in sliding the fence over the table. A small gap between the fence and table results from this plate.

If there is a sizeable gap, refer to your 10-325 manual for the mounting and re-positioning of the front fence rail.

RE-SAWING

A re-saw guide bar is supplied to help correct any blade wandering during certain re-sawing operations.

For re-sawing, attach the re-saw bar to the slot on the fence. Position the re-saw bar so that it is aligned with the front of the blade. Draw a reference line down the workpiece. Use the bar as a pivot point, angling the wood left or right while against the bar, to follow the line through the cut. Fig. 1.

NOTE: The re-saw bar is not needed for all re-saw operations. Proper blade tension and selection, as well as proper guide set up, will allow re-sawing flat stock against the fence without the use of the re-saw bar.

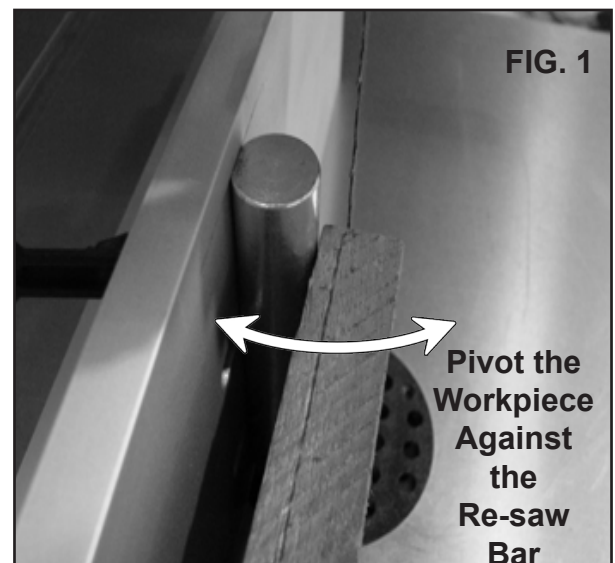

NOTE: Please reference the Part Number when calling in for replacement parts.

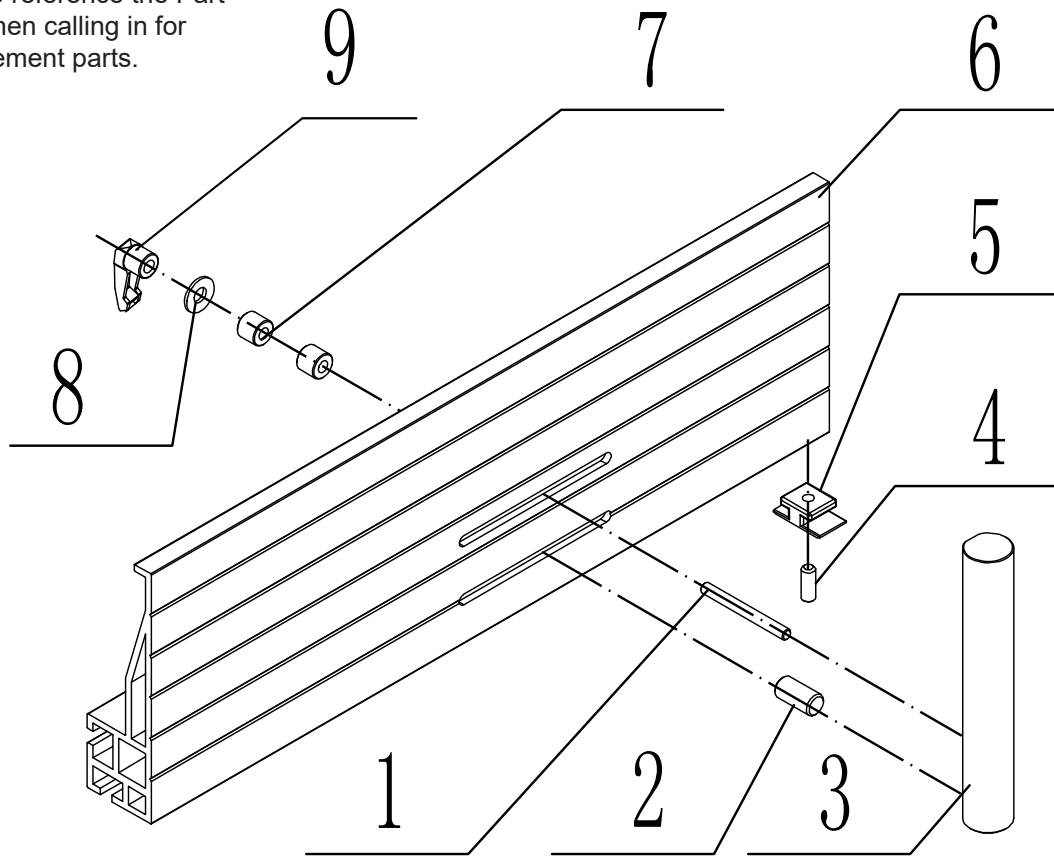

KEY NO.	DESCRIPTION	QTY.	PART NO.
1	Bolt	1	P10-921-1
2	Screw	1	P10-921-2
3	Re-Saw Bar	1	P10-921-3
4	Set Screw M6x16	1	P10-921-4
5	Nylon Pad	1	P10-921-5
6	Fence	1	P10-921-6
7	Tube	2	P10-921-7
8	Washer	1	P10-921-8
9	Locking Handle	1	P10-921-9

SAVE THESE INSTRUCTIONS.

Store them with your Bandsaw's Operator's Manual for future reference.

For technical support or parts questions, email techsupport@rikontools.com or call toll free at (877)884-5167

CALIFORNIA PROPOSITION 65 WARNING: This product contains chemicals known to the State of California to cause cancer and birth defects or other reproductive harm.

NOTE: The specifications, photographs, drawings and information in this manual represent the current model when the manual was prepared. Changes and improvements may be made at any time, with no obligation on the part of Rikon Power Tools, Inc. to modify previously delivered units.