

FLEXIBLE/EXPANDABLE ROLLER STAND 200LB CAPACITY
SUPPORT de ROULEAU FLEXIBLE/EXTENSIBLE 200LB CAPACITE
PLATAFORMA de RODILLOS FLEXIBLE/EXPANDIBLE con CAPACIDAD de 200 LIBRAS

SPECIFICATIONS

Number of Rollers	9
Roller Length.....	13-3/4" (349.25 mm)
Roller Daimeter.....	1-1/2" (38.10 mm)
Expanded Length.....	50" (1,270 mm)
Compacted Length.....	14-3/4" (374.65 mm)
Adjustable Height.....	23" to 36" (584.20 to 914.40 mm)
Number of Locking Casters	4
Caster Diameter.....	3" (76.20 mm)
Load Capacity.....	200 lbs (90.72 kg)
Net Weight	46 lbs (20.87 kg)

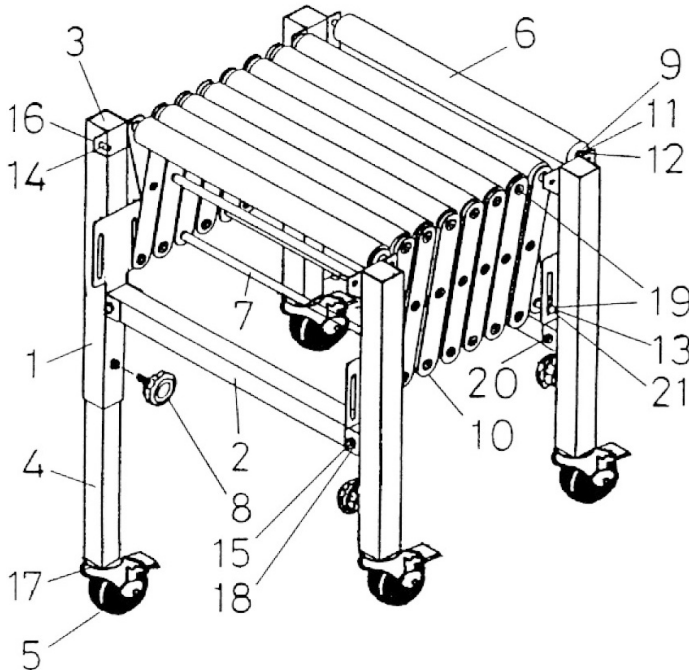
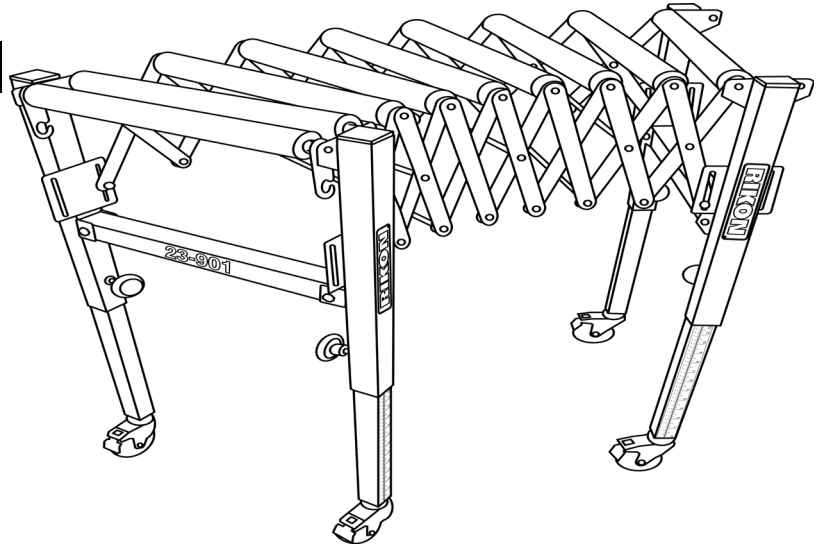

KEY NO.	DESCRIPTION	QTY	MFG. PART NO.
1	OUTER LEG	4	P23-901-1
2	BASE TUBE	2	P23-901-2
3	END CAP	4	P23-901-3
4	INNER EXTENSION LEG	4	P23-901-4
5	LOCKING CASTER 3"	4	P23-901-5
6	ROLLER 1-1/2" x 13-3/4"	9	P23-901-6
7	TUBE SPACER	13	P23-901-7
8	LOCK KNOB	4	P23-901-8
9	COUPLER	1	P23-901-9
10	SIDE EXPANSION PLATES	2	P23-901-10
11	COUPLER	2	P23-901-11
12	RING	2	P23-901-12
13	CARRIAGE BOLT 1/4" x 1"	4	P23-901-13
14	HEX HEAD BOLT 1/4" x 1"	2	P23-901-14
15	HEX HEAD BOLT M8-55	4	P23-901-15
16	HEX NUT 1/4"	4	P23-901-16
17	HEX NUT 1/2"	4	P23-901-17
18	WASHER 5/16"	8	P23-901-18
19	LOCK NUT 1/4"	32	P23-901-19
20	LOCK NUT M8	4	P23-901-20
21	WASHER 1/4"	4	P23-901-21

NOTE: Please reference the Manufacturer's Part Number when calling for Replacement Parts.

REMARQUE: Veuillez citer le numéro de pièce du fabricant lorsque vous appelez pour remplacer des pièces.

NOTA: Por favor, referencia al Número del fabricante cuando llamas a pedir Partes de reemplazo.

