

17" Floor Drill Press



Operator's Manual

Record the serial number and date of purchase in your manual for future reference.

The serial number can be found on the specification label on the rear of your machine.

Serial Number: _____ Date of purchase: _____

For technical support or parts questions, email techsupport@rikontools.com or call toll free at (877)884-5167

TABLE OF CONTENTS

Specifications.....	2
Safety Instructions	3 - 6
Getting To Know Your Machine	7
Contents of Package	7 - 8
Installation	8
Assembly	9 - 12
Adjustments.....	12 - 15
Operation	15
Maintenance	16
Electricals & Wiring Diagram	5 & 16
Parts Diagrams & Parts Lists	17 - 21
Troubleshooting	22
Accessories	23
Warranty	23

SPECIFICATIONS

Motor	1 HP, TEFC
Motor Speed (no load).....	1,720 RPM
Volts	120 V
Amps, Hertz	13.5 A, 60 Hz
Swing	17"
Chuck Size	5/8"
Chuck Taper	JT3
Drilling Capacity	1"
Spindle Travel	3-1/8"
Spindle Taper	MT2
Head Rotates	360°
Speed Range (RPM)	200 - 3,630
Speeds	16
Quill Diameter	66mm (2-19/32")
Table Size	13-3/4" x 13-3/4"
Table Tilts	90° Left & Right
Table Rotates	360°
Maximum Chuck to Table	25-1/4"
Maximum Chuck to Base	44-13/16"
Column Diameter	80mm (3-1/8")
Height	64-3/8"
Base Size (LxW)	22-1/2" x 17-1/2"
Net Weight	188 lbs.

NOTE: The specifications, photographs, drawings and information in this manual represent the current model when the manual was prepared. Changes and improvements may be made at any time, with no obligation on the part of Rikon Power Tools, Inc. to modify previously delivered units. Reasonable care has been taken to ensure that the information in this manual is correct, to provide you with the guidelines for the proper safety, assembly and operation of this machine.

SAFETY INSTRUCTIONS

IMPORTANT! Safety is the single most important consideration in the operation of this equipment. **The following instructions must be followed at all times.** Failure to follow all instructions listed below may result in electric shock, fire, and/or serious personal injury.

There are certain applications for which this tool was designed. We strongly recommend that this tool not be modified and/or used for any other application other than that for which it was designed. If you have any questions about its application, do not use the tool until you have contacted us and we have advised you.

SAFETY SYMBOLS



SAFETY ALERT SYMBOL: Indicates DANGER, WARNING, or CAUTION. This symbol may be used in conjunction with other symbols or pictographs.



Indicates an imminently hazardous situation, which, if not avoided, could result in death or serious injury.



Indicates a potentially hazardous situation, which, if not avoided, could result in death or serious injury.



Indicates a potentially hazardous situation, which, if not avoided, could result in minor or moderate injury.

NOTICE: Shown without Safety Alert Symbol indicates a situation that may result in property damage.

GENERAL SAFETY

KNOW YOUR POWER TOOL. Read the owner's manual carefully. Learn the tool's applications, work capabilities, and its specific potential hazards.

BEFORE USING YOUR MACHINE

To avoid serious injury and damage to the tool, read and follow all of the Safety and Operating Instructions before operating the machine.

1. Some dust created by using power tools contains chemicals known to the State of California to cause cancer, birth defects, or other reproductive harm.

Some examples of these chemicals are:

- Lead from lead-based paints.
- Crystalline silica from bricks, cement, and other masonry products.
- Arsenic and chromium from chemically treated lumber.

Your risk from these exposures varies, depending on how often you do this type of work. To reduce your exposure to these chemicals: work in a well ventilated area and work with approved safety equipment, such as those dust masks that are specially designed to filter out microscopic particles.

2. **READ** the entire Owner's Manual. **LEARN** how to use the tool for its intended applications.

3. **GROUND ALL TOOLS.** If the tool is supplied with a 3 prong plug, it must be plugged into a 3-contact electrical receptacle. The 3rd prong is used to ground the tool and provide protection against accidental electric shock. **DO NOT** remove the 3rd prong. See Grounding Instructions on the following pages.

4. **AVOID A DANGEROUS WORKING ENVIRONMENT.** **DO NOT** use electrical tools in a damp environment or expose them to rain.

5. **DO NOT** use electrical tools in the presence of flammable liquids or gasses.

6. **ALWAYS** keep the work area clean, well lit, and organized. **DO NOT** work in an environment with floor surfaces that are slippery from debris, grease, and wax.

7. **KEEP VISITORS AND CHILDREN AWAY. DO NOT** permit people to be in the immediate work area, especially when the electrical tool is operating.

8. **DO NOT FORCE THE TOOL** to perform an operation for which it was not designed. It will do a safer and higher quality job by only performing operations for which the tool was intended.

9. **WEAR PROPER CLOTHING. DO NOT** wear loose clothing, gloves, neckties, or jewelry. These items can get caught in the machine during operations and pull the operator into the moving parts. The user must wear a protective cover on their hair, if the hair is long, to prevent it from contacting any moving parts.

10. **CHILDPROOF THE WORKSHOP AREA** by removing switch keys, unplugging tools from the electrical receptacles, and using padlocks.

11. **ALWAYS UNPLUG THE TOOL FROM THE ELECTRICAL RECEPTACLE** when making adjustments, changing parts or performing any maintenance.

SAFETY INSTRUCTIONS

12. KEEP PROTECTIVE GUARDS IN PLACE AND IN WORKING ORDER.

13. AVOID ACCIDENTAL STARTING. Make sure that the power switch is in the “OFF” position before plugging in the power cord to the electrical receptacle.

14. REMOVE ALL MAINTENANCE TOOLS from the immediate area prior to turning “ON” the machine.

15. USE ONLY RECOMMENDED ACCESSORIES. Use of incorrect or improper accessories could cause serious injury to the operator and cause damage to the tool. If in doubt, check the instruction manual that comes with that particular accessory.

16. NEVER LEAVE A RUNNING TOOL UNATTENDED. Turn the power switch to the “OFF” position. **DO NOT** leave the tool until it has come to a complete stop.

17. DO NOT STAND ON A TOOL. Serious injury could result if the tool tips over, or you accidentally contact the tool.

18. DO NOT store anything above or near the tool where anyone might try to stand on the tool to reach it.

19. MAINTAIN YOUR BALANCE. DO NOT extend yourself over the tool. Wear oil resistant rubber soled shoes. Keep floor clear of debris, grease, and wax.

20. MAINTAIN TOOLS WITH CARE. Always keep tools clean and in good working order. Keep all blades and tool bits sharp, dress grinding wheels and change other abrasive accessories when worn.

21. EACH AND EVERY TIME, CHECK FOR DAMAGED PARTS PRIOR TO USING THE TOOL. Carefully check all guards to see that they operate properly, are not damaged, and perform their intended functions. Check for alignment, binding or breaking of moving parts. A guard or other part that is damaged should be immediately repaired or replaced.

22. DO NOT OPERATE TOOL WHILE TIRED, OR UNDER THE INFLUENCE OF DRUGS, MEDICATION OR ALCOHOL.

23. SECURE ALL WORK. Use clamps or jigs to secure the work piece. This is safer than attempting to hold the work piece with your hands.

24. STAY ALERT, WATCH WHAT YOU ARE DOING, AND USE COMMON SENSE WHEN OPERATING A POWER TOOL.

A moment of inattention while operating power tools may result in serious personal injury.

25. ALWAYS WEAR A DUST MASK TO PREVENT INHALING DANGEROUS DUST OR AIRBORNE PARTICLES, including wood dust, crystalline silica dust and asbestos dust. Direct particles away from face and body. Always operate tool in well ventilated area and provide for proper dust removal. Use dust collection system wherever possible. Exposure to the dust may cause serious and permanent respiratory or other injury, including silicosis (a serious lung disease), cancer, and death. Avoid breathing the dust, and avoid prolonged contact with dust. Allowing dust to get into your mouth or eyes, or lay on your skin may promote absorption of harmful material. Always use properly fitting NIOSH/OSHA approved respiratory protection appropriate for the dust exposure, and wash exposed areas with soap and water.

26. USE A PROPER EXTENSION CORD IN GOOD CONDITION. When using an extension cord, be sure to use one heavy enough to carry the current your product will draw. The table on the following page shows the correct size to use depending on cord length and nameplate amperage rating. If in doubt, use the next heavier gauge. The smaller the gauge number, the larger diameter of the extension cord. If in doubt of the proper size of an extension cord, use a shorter and thicker cord. An undersized cord will cause a drop in line voltage resulting in a loss of power and overheating.
USE ONLY A 3-WIRE EXTENSION CORD THAT HAS A 3-PRONG GROUNDING PLUG AND A 3-POLE RECEPTACLE THAT ACCEPTS THE TOOL’S PLUG.

27. ADDITIONAL INFORMATION regarding the safe and proper operation of this product is available from:

- Power Tool Institute
1300 Summer Avenue
Cleveland, OH 44115-2851
www.powertoolinstitute.org
- National Safety Council
1121 Spring Lake Drive
Itasca, IL 60143-3201
www.nsc.org
- American National Standards Institute
25 West 43rd Street, 4th Floor
New York, NY 10036
www.ansi.org
- ANSI 01.1 Safety Requirements for Woodworking Machines and the U.S. Department of Labor regulations
www.osha.gov

28. SAVE THESE INSTRUCTIONS. Refer to them frequently and use them to instruct others.

SAFETY INSTRUCTIONS

ELECTRICAL SAFETY

⚠ WARNING: THIS 120V TOOL MUST BE GROUND-ED WHILE IN USE TO PROTECT THE OPERATOR FROM ELECTRIC SHOCK.

IN THE EVENT OF A MALFUNCTION OR BREAKDOWN, grounding provides the path of least resistance for electric current and reduces the risk of electric shock. This tool is equipped with an electric cord that has an equipment grounding conductor and requires a grounding plug (not included). The plug **MUST** be plugged into a matching electrical receptacle that is properly installed and grounded in accordance with **ALL** local codes and ordinances.

DO NOT MODIFY ANY PLUG. If it will not fit the electrical receptacle, have the proper electrical receptacle installed by a qualified electrician.

IMPROPER ELECTRICAL CONNECTION of the equipment grounding conductor can result in risk of electric shock. The conductor with the green insulation (with or without yellow stripes) is the equipment grounding conductor. **DO NOT** connect the equipment grounding conductor to a live terminal if repair or replacement of the electric cord or plug is necessary.

CHECK with a qualified electrician or service personnel if you do not completely understand the grounding instructions, or if you are not sure the tool is properly grounded when installing or replacing a plug.

USE ONLY A 3-WIRE EXTENSION CORD THAT HAS THE PROPER TYPE OF A 3-PRONG GROUNDING PLUG THAT MATCHES THE MACHINE'S 3-PRONG PLUG AND ALSO THE 3-POLE RECEPTACLE THAT ACCEPTS THE TOOL'S PLUG. *

REPLACE A DAMAGED OR WORN CORD IMMEDIATELY.

This tool is intended for use on a circuit that has an electrical receptacle as shown in **FIGURE A**. It shows a 3-wire electrical plug and electrical receptacle that has a grounding conductor. If a properly grounded electrical receptacle is not available, an adapter as shown in **FIGURE B** can be used to temporarily connect this plug to a 2-contact ungrounded receptacle. The adapter has a rigid lug extending from it that **MUST** be connected to a permanent earth ground, such as a properly grounded receptacle box. **THIS ADAPTER IS PROHIBITED IN CANADA.**

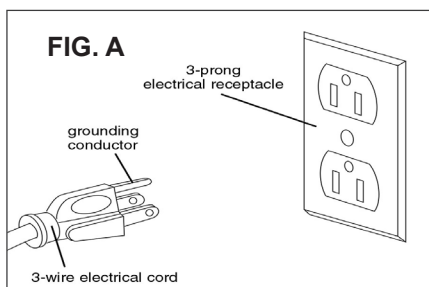

EXTENSION CORDS

⚠ WARNING: THE USE OF AN EXTENSION CORD WITH THIS MACHINE IS NOT RECOMMENDED. For best power and safety, plug the machine directly into a dedicated, grounded electrical outlet that is within the supplied cord length of the machine.

If an extension cord needs to be used, it should only be for a limited operation of the machine. The extension cord should be as short as possible in length, and have a minimum gauge size of 14AWG.

⚠ WARNING: Check extension cords before each use. If damaged replace immediately. Never use a tool with a damaged cord, since touching the damaged area could cause electrical shock, resulting in serious injury.

Use a proper extension cord. Only use cords listed by Underwriters Laboratories (UL). Other extension cords can cause a drop in line voltage, resulting in a loss of power and overheating of tool. When operating a power tool outdoors, use an outdoor extension cord marked "W-A" or "W". These cords are rated for outdoor use and reduce the risk of electric shock.

MINIMUM RECOMMENDED GAUGE FOR EXTENSION CORDS (AWG)

120 VOLT OPERATION ONLY				
	25' LONG	50' LONG	100' LONG	150' LONG
0 to 6 Amps	18 AWG	16 AWG	16 AWG	14 AWG
6 to 10 Amps	18 AWG	16 AWG	14 AWG	12 AWG
10 to 12 Amps	16 AWG	16 AWG	14 AWG	12 AWG

⚠ WARNING: Keep the extension cord clear of the working area. Position the cord so that it will not get caught on lumber, tools or other obstructions while you are working with your power tool.

* Canadian electrical codes require extension cords to be certified SJT type or better.

** The use of an adapter in Canada is not acceptable.

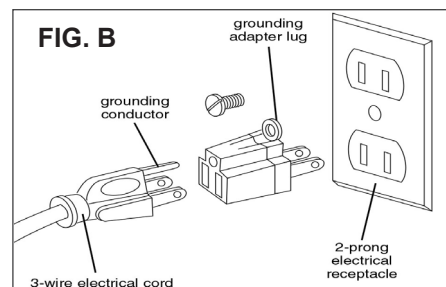

SAFETY INSTRUCTIONS

SPECIFIC SAFETY INSTRUCTIONS FOR DRILL PRESSES

This machine is intended for the drilling of wood, composite materials, plastics, ferrous and non-ferrous metals. The permissible workpiece dimensions must be observed (see Technical Specification). Any other use not as specified, including modification of the machine or use of parts not tested and approved by the equipment manufacturer, can cause unforeseen damage and invalidate the warranty.

ATTENTION: Use of this drill press still presents risks that cannot be eliminated by the manufacturer. Therefore, the user must be aware that wood working machines are dangerous if not used with care and all safety precautions are adhered to.

1. Do not operate the Drill Press until it is assembled and you have read all of the instructions.
2. Do not operate the Drill Press unless you are familiar with its safe operation. If you are not familiar with the operation of a Drill Press seek advice from your supervisor, instructor or other qualified individual.
3. If you are using a bench top Drill Press, it must be securely fastened to a stand or bench.
4. If you are operating a floor Drill Press it must be securely fastened to the floor.
5. Always clear the table and work area before turning on the Drill Press.
6. Always use drill bits, cutting tools and accessories with a 1/2" shank or less.
7. Never place hands near the drill bit, cutting tool or accessory while operating the Drill Press.
8. Always wear approved, safety eye wear and hearing protection while operating the Drill Press.
9. Never wear loose clothing, gloves or ties while operating the Drill Press. Tie loose hair back.
10. Always wear a dust mask and use adequate dust collection and proper ventilation.
11. Always have a firm footing while operating the Drill Press.
12. Always keep the work surface and work areas clear of debris.
13. Never attempt to do set-up work, assembly or layout work on the Drill Press while it is in operation.
14. Always lock all table, column and head locks before turning on the Drill Press.
15. Never start the Drill Press with the drill bit, cutting tool or accessory in contact with the work piece.
16. Never operate the Drill Press with a damaged drill bit, cutting tool or accessory.
17. Always check that the drill bit, cutting tool or accessory is held tight in the chuck.
18. Never operate the Drill Press with the chuck key in the chuck.
19. Always adjust the depth stop to avoid drilling into the table surface.
20. Never drill material unless it is properly supported. Non flat work pieces require additional support.
21. Always clamp the work piece to the table.
22. Always support large work pieces at the same height as the table.
23. Never remove the work piece or clear the table until the Drill Press comes to a complete stop.
24. Never operate the Drill Press with missing, damaged, worn, loose or defective parts.
25. Never adjust, change speeds or perform maintenance on the Drill Press while it is operating.
26. Always clean the work surface and work area when finished operating the Drill Press.
27. Always disconnect the power when adjusting or performing maintenance on the Drill Press.
28. Always disconnect the power when finished using the Drill Press to prevent accidental operation.

SAVE THESE INSTRUCTIONS. Refer to them often.

This owner's manual is not a teaching aid. Use of this owner's manual is intended to show assembly, adjustments, and general use.



WARNING: Drilling, sawing, sanding or machining wood products can expose you to wood dust, a substance known to the State of California to cause cancer. Avoid inhaling wood dust or use a dust mask or other safeguards for personal protection.

For more information go to www.P65Warnings.ca.gov/wood.

GETTING TO KNOW YOUR MACHINE

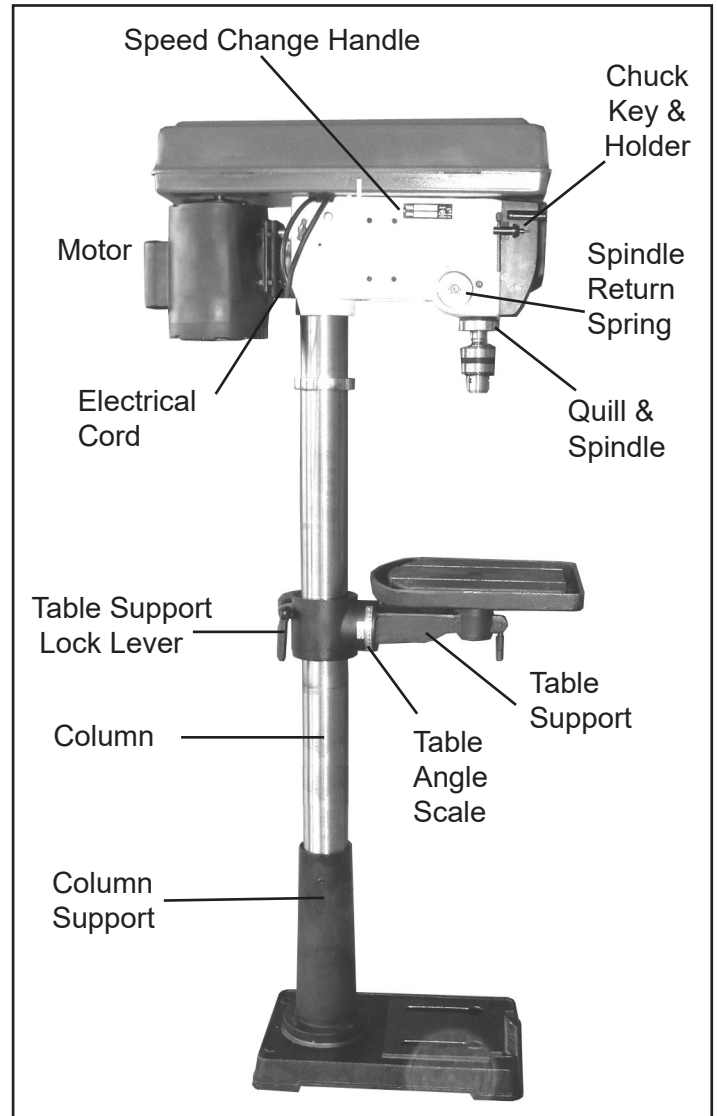
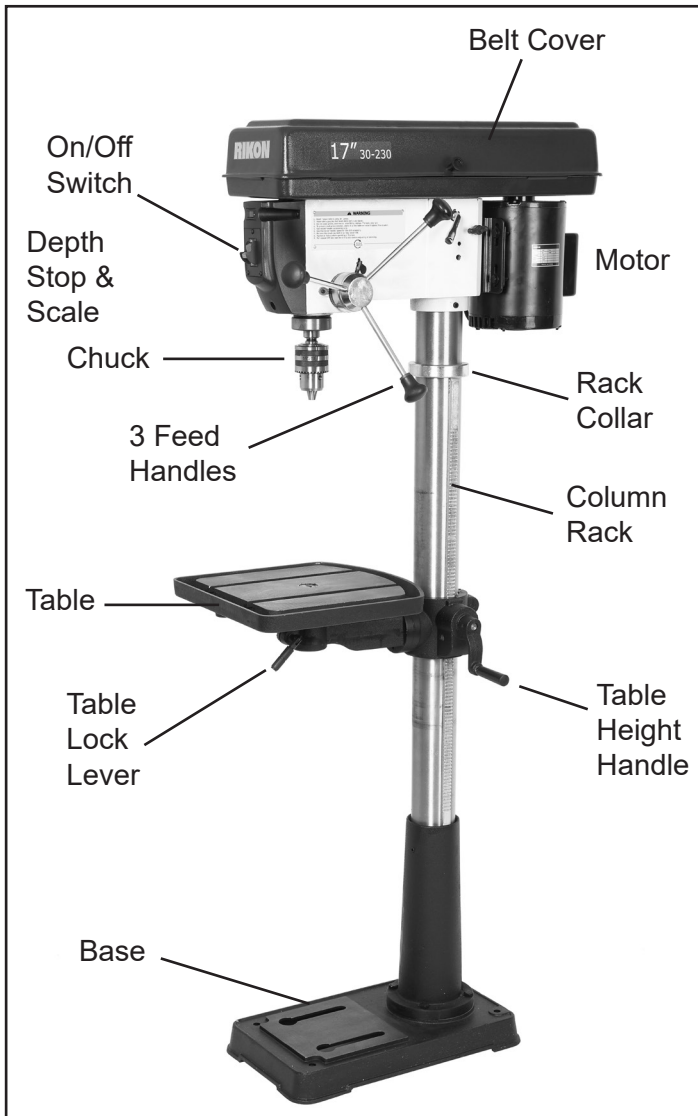

CONTENTS OF PACKAGE

Model #30-230 17" Drill Press is shipped complete in one box.

Unpacking and Clean-up

1. Carefully remove all contents from the shipping carton. Compare the contents with the list of contents to make sure that all of the items are accounted for, before discarding any packing material. Place parts on a protected surface for easy identification and assembly. If any parts are missing or broken, please call RIKON Customer Service (877-884-5167) as soon as possible for replacements. DO NOT turn your machine ON if any of these items are missing. You may cause injury to yourself or damage to the machine.
2. Report any shipping damage to your local distributor. Take photographs for any possible insurance claims.
3. Clean all rust protected surfaces with ordinary house hold type grease or spot remover. Do not use; gasoline, paint thinner, mineral spirits, etc. These may damage painted surfaces.
4. Apply a coat of paste wax to the table to prevent rust. Wipe all parts thoroughly with a clean dry cloth.
5. Set packing material and shipping carton aside. Do not discard until the machine has been set up and is running properly.

CONTENTS OF PACKAGE

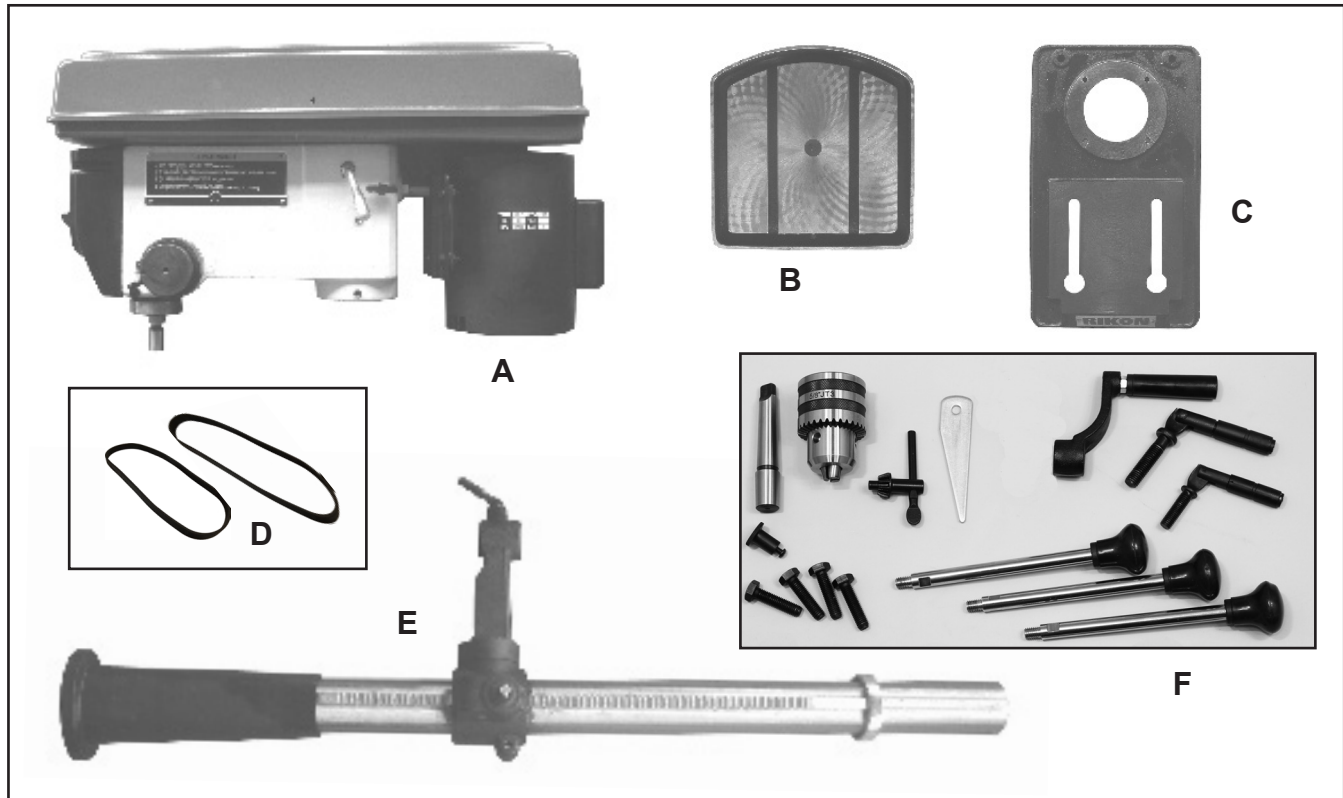

LIST OF LOOSE PARTS

- | | |
|---|---|
| <p>A Drill Press Head Assembly
 B Table
 C Base
 D Drive Belts
 E Column Assembly</p> | <p>F Parts Bags include:
 Chuck, Chuck Arbor, Chuck Key,
 Drift Key, Handles (3), Lid Knob,
 Bolts (4), Feed Handles (3)
 G Owner's Manual &
 Warranty Card (not shown)</p> |
|---|---|

Tools Needed for Assembly

- Phillips Screwdriver
- 10mm, 16mm, 24mm or Adjustable Wrench
- Rubber Mallet or Hammer & Block of Wood

INSTALLATION

MOVING & INSTALLING THE DRILL PRESS

CAUTION When moving the assembled Drill Press, at least two people are needed. The machine is extremely heavy, and top heavy. Tilt the drill press backwards so that one person can hold the head section. Then the base can be lifted by the second person, and the machine moved to the desired new location. **DO NOT** move or carry the Drill Press with the work table, chuck or operating handles, as this may damage the machine.

1. Position the machine on a solid, level foundation that is located in an area that has ample space in front and to both sides of the drill press for the moving of lumber and projects to be drilled.

2. Align the machine so that during use, any kickback will not face aisles, doorways, or other work areas that bystanders may be in. Do not locate or use the machine in damp or wet conditions.

3. If possible, secure the machine to the floor with lag screws or other fasteners (not supplied). This will ensure the stability of the machine and reduce any possible vibration during use. If this is not possible, the base can be bolted to a larger piece of plywood to help stabilize the machine. **DO NOT** use a mobile base with this machine.

4. For best power and safety, the Drill Press should be directly plugged into a dedicated grounded electrical outlet that is within the supplied cord length of the machine. The use of an extension cord is not recommended.

ASSEMBLY

⚠ WARNING THE MACHINE MUST NOT BE PLUGGED IN AND THE POWER SWITCH MUST BE IN THE OFF POSITION UNTIL ASSEMBLY IS COMPLETE.

BASE AND COLUMN ASSEMBLY

1. Place the base (A-Fig. 1) on a level floor where the machine will be used.
2. Attach the column (B-Fig.1) to the base (A-Fig. 1) using four M10x40 hex bolts. Tighten all four bolts.

NOTE: The column is shipped with the toothed Rack (#15A), Collar Rack (#2A) and Table Arm Assembly pre-assembled on the column. The column should be positioned on the base with the table arm facing forward with the rack to the right side of the column.

3. Check the Hex Screw (#13A) on the side of the support column (B-Fig. 1), and the Hex Screw (#1A) on the Collar Rack (#2A) to make sure that they are secure.

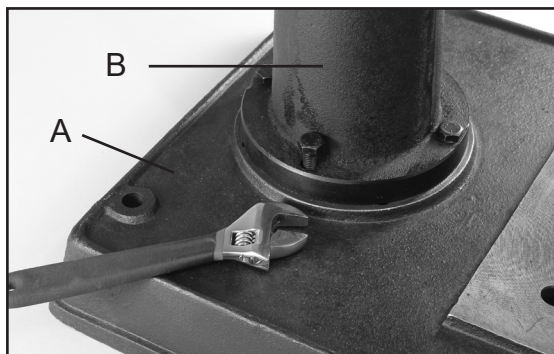

Figure 1

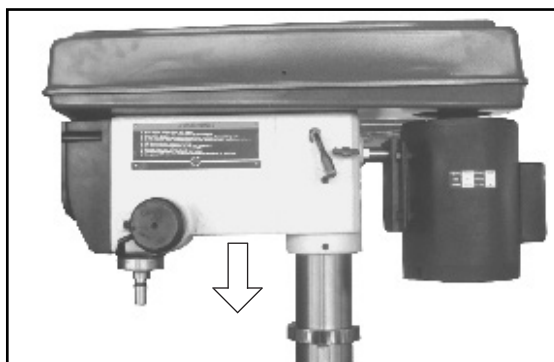

Figure 2

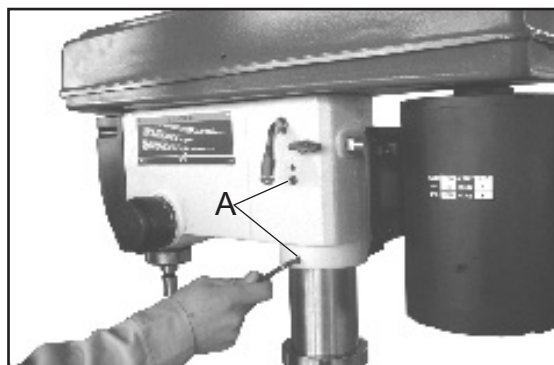

Figure 3



Figure 4

HEAD ASSEMBLY

⚠ CAUTION Assistance is needed for this next step.

1. Place the drill press head onto the column as far down as it will go (Figure 2). Then align the drill press head with the base of the drill press.
2. Tighten the drill press head to the column by tightening the two set screws on the right side of the head as shown (A-Figure 3).
3. Install the three feed Handles (#9D) into the threaded holes in the Handle Seat/Hub (#7D). Use a 10mm or adjustable wrench (not supplied) to secure the handles in place. (Figure 4).

ASSEMBLY

⚠ WARNING THE MACHINE MUST NOT BE PLUGGED IN AND THE POWER SWITCH MUST BE IN THE OFF POSITION UNTIL ASSEMBLY IS COMPLETE.

4. To install the belt cover Knob (#12C), open the belt cover and insert the Phillips head screw through the hole in the center from the inside. Thread the handle on the outside of the belt cover and tighten in place with a screwdriver (Figure 5).



Figure 5

5. Install the idler pulley and drive belts, if they have not been pre-installed at the factory. Simply slide the pivot post of the idler pulley into the corresponding hole in the drill press head. The small drive belt (#17C) is mounted to the motor pulley and the large drive belt (#4C) is mounted to the spindle pulley (Figure 6).



Figure 6

6. Release the locking knobs on the both sides of drill press head. Release the tension on the belt by swinging the tension lever from right to left (Figure 7).

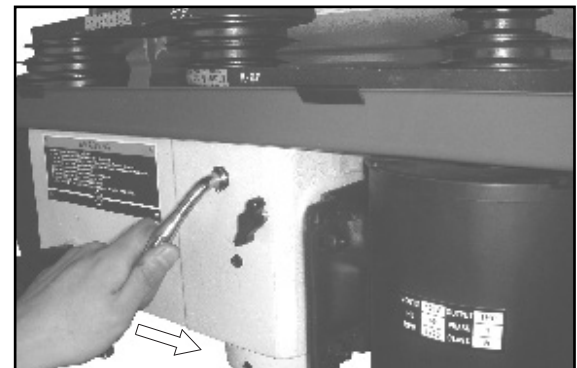

Figure 7

Choose the desired speed by referring to the speed selection chart under the belt cover.

See page 12 for instructions on changing speeds.

INSTALLING & REMOVING THE CHUCK

IMPORTANT! It is very important that the tapered hole in the chuck, tapered hole in the spindle and both tapered ends of the arbor are free of any grease, oil, lacquer or rust protection.

These tapered surfaces must be absolutely clean for a precision fitting of the parts, so slipping of the chuck during use does not occur unless there is extreme rotational pressure during use. This is a safety feature of this type of friction fit joint.

ASSEMBLY

INSTALLING THE CHUCK

1. Carefully insert the arbor's short, JT3 tapered end into the rear tapered hole of the chuck. (Figure 8).
2. Next, take the chuck and insert the long, MT2 tapered end of the arbor into the drill press spindle's tapered hole. Make sure to align the flat part of the arbor with the slot in the spindle. (Figure 9).
3. Open the jaws of the chuck until the 3 jaws are completely hidden inside of the chuck body.
4. Using a rubber mallet, or hammer with a block of wood protecting the chuck, tap the chuck with its arbor into the drill press spindle. This will securely seat the chuck in place for drilling. (Figure 10).

CAUTION NEVER HIT THE CHUCK WITH A METAL HAMMER. This could damage the chuck assembly, arbor or drill press spindle.

REMOVING THE CHUCK

1. Open the chuck jaws as wide as possible to prevent damage in the following steps.
2. Lower the spindle until the slot in the spindle is exposed and lock it in place. (Figure 11). See page 13 for instructions on locking the spindle.
3. Turn the chuck until the slots in the spindle (#11B) and Quill (#6B) align, and a through-hole is exposed.
4. Insert the Key-Drift (#10B), into the slots and hole above the chuck arbor, with the drift's flat side up. (Figure 11).
5. Gently tap the key-drift with a mallet to release the chuck. **NOTE:** Be prepared to catch the chuck as it is released to prevent any damage to it or the arbor.

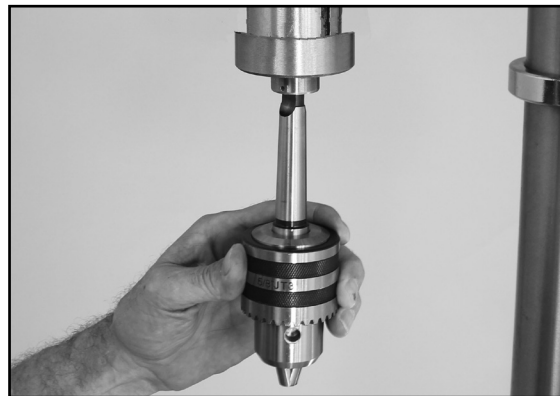

Figure 8

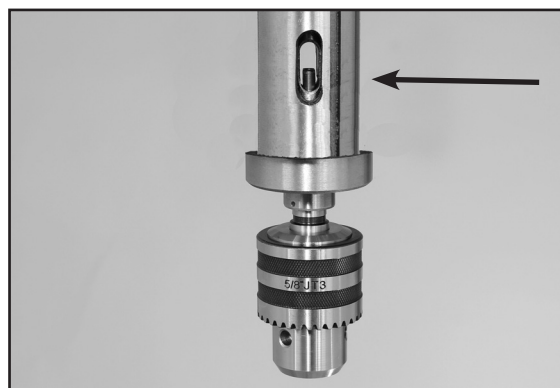

Figure 9



Figure 10

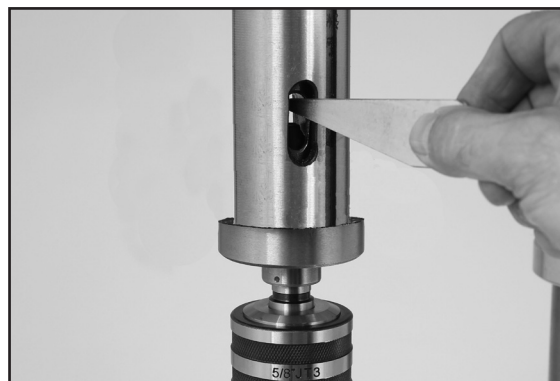

Figure 11

ASSEMBLY

⚠ WARNING THE MACHINE MUST NOT BE PLUGGED IN AND THE POWER SWITCH MUST BE IN THE OFF POSITION UNTIL ASSEMBLY IS COMPLETE.

INSTALLING THE TABLE

1. Install the large Locking Lever (#16A) onto the rear joint of the table support bracket and tighten the locking lever. (Figure 12).

2. Install the table raising/lowering crank Handle (#4A) to the side shaft of the Table Support (#17A) with a hex wrench. (Figure 13).

3. If not pre-installed at the factory, install the small Locking Lever (#7A, Figure 14, A) onto the front joint of the Table Support Bracket (#9A, B). (Figure 14).

4. Insert the table post (C) into the table support bracket (B) as shown in Figure 14. Tighten the locking lever (A) to secure the table in position.

NOTE: The table can rotate 360° by loosening the table lock handle and turning to the desired position.

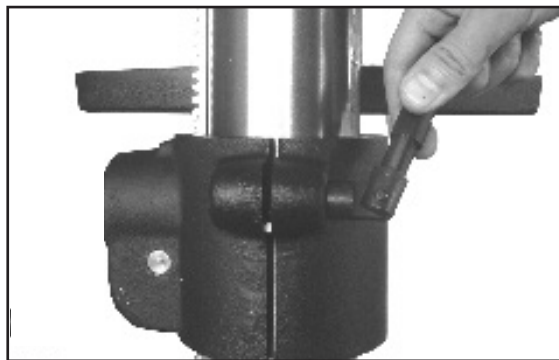

Figure 12



Figure 13

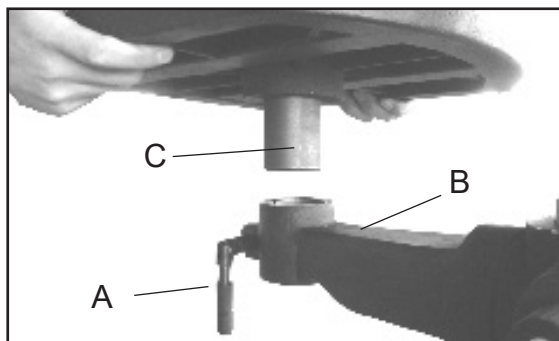

Figure 14

ADJUSTMENTS

CHANGING SPINDLE SPEEDS

1. **⚠ WARNING** Turn off and disconnect the power to the Drill Press.

2. Open the machine's top belt cover.

3. Release the locking knobs (#1D) on the both sides of drill press head. Release the tension on the belt by swinging the tension lever (#3D) from right to left (Figure 15).

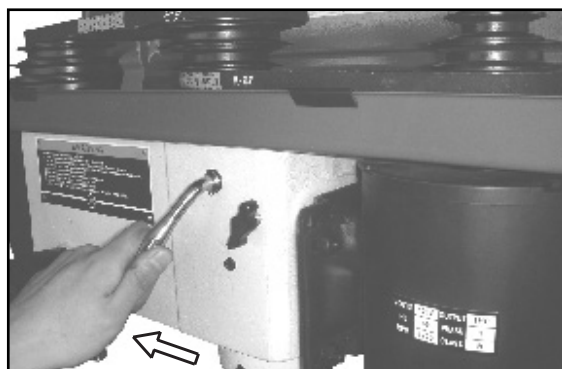

Figure 15

CONTINUED ON NEXT PAGE

ADJUSTMENTS

4. Choose the desired speed by referring to the speed selection chart that is attached to the lid interior.

5. Position the belts on the pulleys in relation to the speed chosen on the speed selection chart starting with the motor pulley first. (Figure 16).

6. When both belts are in the desired positions on the pulleys, swing back the tension lever until there is approximately 1/2" deflection in the belt.

7. Tighten the locking knob on the both sides of drill press head to secure the belt position and tension in place for operation.

SPINDLE SPEEDS IN R.P.M.			
200	290	350	430
500	580	640	720
800	870	1440	1630
1820	2380	2540	3630

Figure 16

8. Close the top belt guard cover and the drill press is ready to be plugged in to use.

⚠ WARNING THE MACHINE MUST NOT BE PLUGGED IN AND THE POWER SWITCH MUST BE IN THE OFF POSITION UNTIL ALL ADJUSTMENTS ARE COMPLETE.

SETTING THE SPINDLE LOCK

1. Loosen the depth stop collar locking screw (#6D) that extends out from the hub. (Figure 17, A).

2. Lower the spindle to the desired depth for drilling.
NOTE: Photo shown without drill bit installed in the drill chuck. (Figure 18)

3. Turn the depth stop collar clockwise until the collar stops (Figure 17, B).

4. Tighten the depth stop collar lock.

NOTE: Figure 18 shows the spindle in the locked position.

SETTING THE DRILL DEPTH

1. With the spindle in the up position, loosen the depth stop collar lock as shown. (Figure 17, A)

2. Turn the depth stop collar clockwise until the pointer reads the desired drill depth on the scale (Figure 17, B).

3. Tighten the depth stop collar lock. The drill press is now set for repetitive drilling to the same depth.

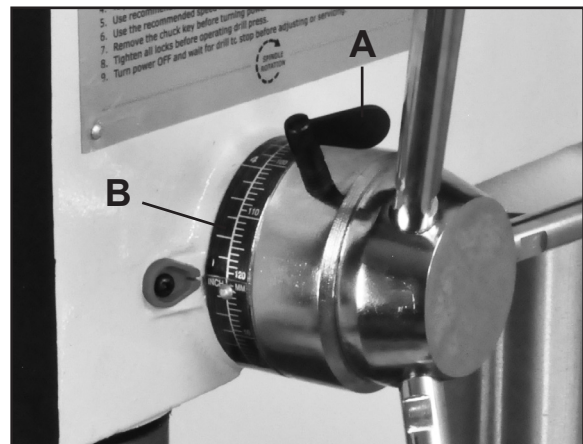

Figure 17

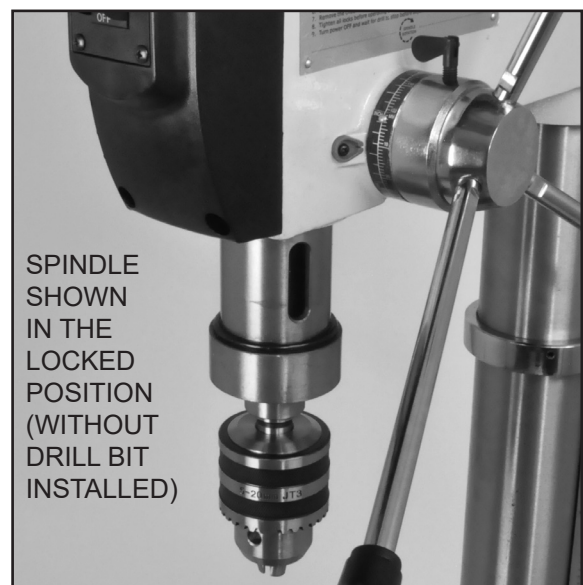

Figure 18

ADJUSTMENTS

⚠ WARNING THE MACHINE MUST NOT BE PLUGGED IN AND THE POWER SWITCH MUST BE IN THE OFF POSITION UNTIL ALL ADJUSTMENTS ARE COMPLETE.

RAISING AND LOWERING THE TABLE

1. Loosen the column lock handle (Figure 19, A) on the table support bracket (B).
2. Turn the crank handle (C) to raise or lower the table to the desired height.
3. Tighten the column lock handle (A).

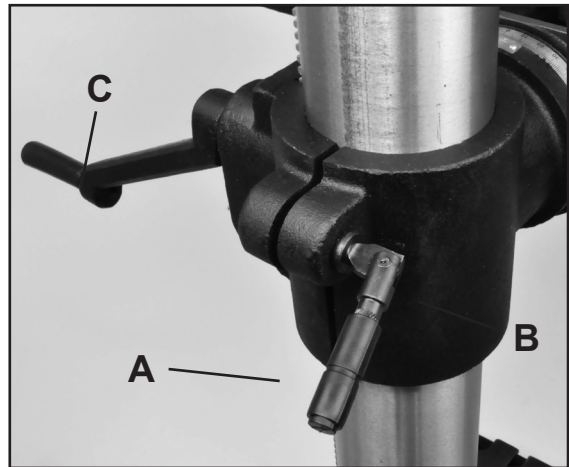

Figure 19

NOTE: The table assembly can rotate 360° around the column by loosening the table lock handle and turning the table to the desired position. The column collar's hex nut may have to be loosened to allow the table assembly with the rack to be rotated. Retighten the collar nut when the table is in final position.

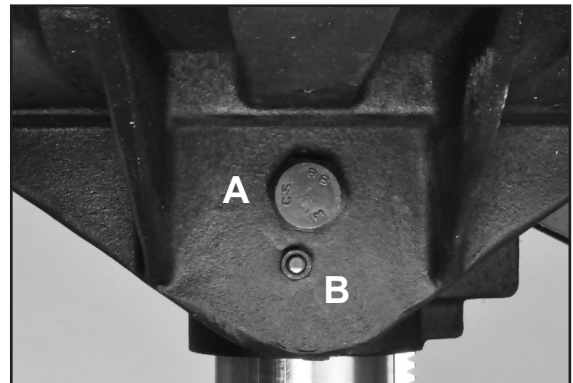

Figure 20

TILTING THE TABLE

1. Loosen the large bolt (#8A) below the table support arm (Figure 20, A). This requires a 24mm (1") socket or adjustable wrench, not included.
2. The small threaded pin with nut below the large bolt (Figure 20, B) positions the table at 90°. *Tighten* the nut to withdraw the pin from its index hole in the support frame so that the table can be tilted from the pre-set 90° position.
3. Tilt the table to the desired angle using the tilt scale and pointer on the bracket to indicate the angle. (Figures 21 & 22).
4. Tighten the large bolt below the table support arm to secure the table in the angled position.
5. To return the table to the original 90° setting, reverse the steps listed above.



Figure 21

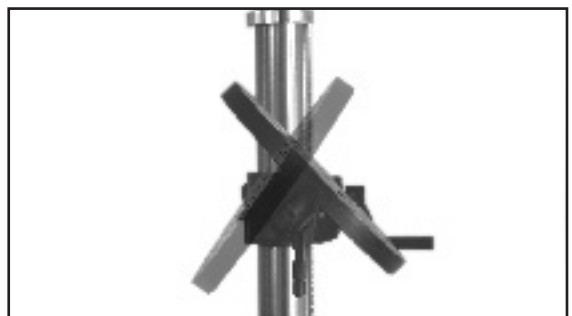

Figure 22

ADJUSTMENTS

SETTING THE RETURN SPRING TENSION

The drill press chuck will automatically return upward to its original starting position when the operating handle is released. The Return Spring Mechanism, Figure 23, has been preset at the factory and should not require any adjustments. However, should the spring tension decline and need adjustment, follow these steps;

1. **⚠ WARNING** Turn off and disconnect the Drill Press from its power source.
2. Loosen the 2 Spring Cover Nuts (A), but DO NOT REMOVE the nuts from the threaded pin.
3. Carefully pull out the Spring Cover (B) slightly, and keep a firm grasp on it - DO NOT LET THE COVER SPIN as it keeps the spring from unwinding. Also, DO NOT let the spring end (C) disengage from its notch in the cover!
4. Pull out the cover just enough so that the notch in the cover clears the nub on the head casting (D).

⚠ WARNING THE MACHINE MUST NOT BE PLUGGED IN AND THE POWER SWITCH MUST BE IN THE OFF POSITION UNTIL ALL ADJUSTMENTS ARE COMPLETE.

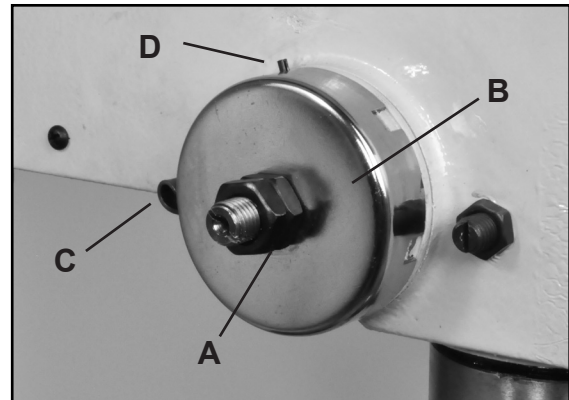

Figure 23

5. Rotate the cover to another notch as needed;
 - *CLOCKWISE* to decrease the spring tension,
 - *COUNTER-CLOCKWISE* to increase spring tension.
6. With the cover in the new position, push it back in place and tighten the spring cover nuts back against the cover to complete the adjustment.

OPERATION

DRILLING SPEEDS

This Drill Press has a speed range from 180 to 3865 RPM. The correct drilling speed for your work depends on a variety of factors:

- a) the workpiece material & hardness
 - wood, composites, plastics or metal
- b) the size of hole diameter
- c) the depth of the hole
- d) the type of drill bit or other cutter needed to make the desired hole diameter and depth
- e) the quality of the bore

We recommend consulting various books, magazine articles, drill bit and material manufacturers' information for information on the proper operating speeds and types of drills for the material or hole desired.

- A general rule: The larger the hole and the harder the material = the slower the RPM speed.

NOTE: See page 6 for important safety information on drilling set-ups and procedures.

WORKPIECE POSITIONING

⚠ WARNING: Always use clamps or hold-downs to secure the material onto the drill press table during drilling. This will prevent the work from being torn from the operator's hand should the drill bit gets caught in the material. Clamping the work to the table is particularly necessary if the table is tilted on an angle.

Place a scrap board or piece of plywood under your work to protect the metal table, drill bit, and to provide a solid base for a clean hole if the drill bit exits the work.

To prevent work from spinning, if possible, position the work to rest against the left side of the column. For shorter pieces, use a clamp or drill press vise secured to the table.

Feed bits into the material at a constant rate to allow the bit to work. Too slowly may cause the wood to burn and ruin the bit. Too fast may put excessive stress on the motor and cause the bit to break.

MAINTENANCE

⚠ WARNING: Turn the power switch “OFF” and disconnect the plug from the outlet prior to adjusting or maintaining the machine. DO NOT attempt to repair or maintain the electrical components of the motor. Contact a qualified service technician for this type of maintenance.

1. Before each use:

- Check the power cord and plug for any wear or damage.
- Check for any loose screws, hardware or parts.
- Check the area to make sure it is clear of any misplaced tools, lumber, cleaning supplies, etc. that could hamper the safe operation of the machine.

2. To avoid a build-up of wood dust, regularly clean all parts of the machine using a soft cloth, brush or compressed air. A general cleaning should be done after every use to avoid future problems and ensure the machine is in ready condition for its next use.

WARNING: If blowing sawdust, wear proper eye protection to prevent debris from blowing into eyes.

3. Keep the machined surfaces of the drill press table and base free of resin and rust. Clean them regularly with a non-flammable solvent, then coat with a light film of dry lubricant spray or wax.

4. Lubricate the table bracket and locking lever bolts to keep them operating smoothly.

5. Clean the column on a regular basis to prevent the build-up of dust, drilling residue and rust. Treat the posts with a dry lubricant spray or a light coating of wax. Do not use ordinary oil which will collect dust and hamper the movement of parts along the column.

6. Periodically, lower the quill assembly and apply a light coating of machine oil to the quill and spindle surfaces. Raise and lower the quill a few times to distribute the oil on all of the internal surfaces.

7. Apply #2 tube grease to the worm gears in the table elevation mechanism and the rack bar to keep them operating smoothly.

8. The ball bearings in the spindle and pulley assemblies are lifetime lubricated, sealed, and do not need any further care.

9. Keep the drive belt and pulley surfaces free of oil and grease. Periodically, check the drive belt for wear and replace if necessary.

Troubleshooting Guide
is listed on page 22.

WIRING DIAGRAM

⚠ WARNING:

This machine must be grounded. Replacement of the power supply cable or any electrical repairs should only be done by a qualified electrician.

See page 5 for additional electrical information.

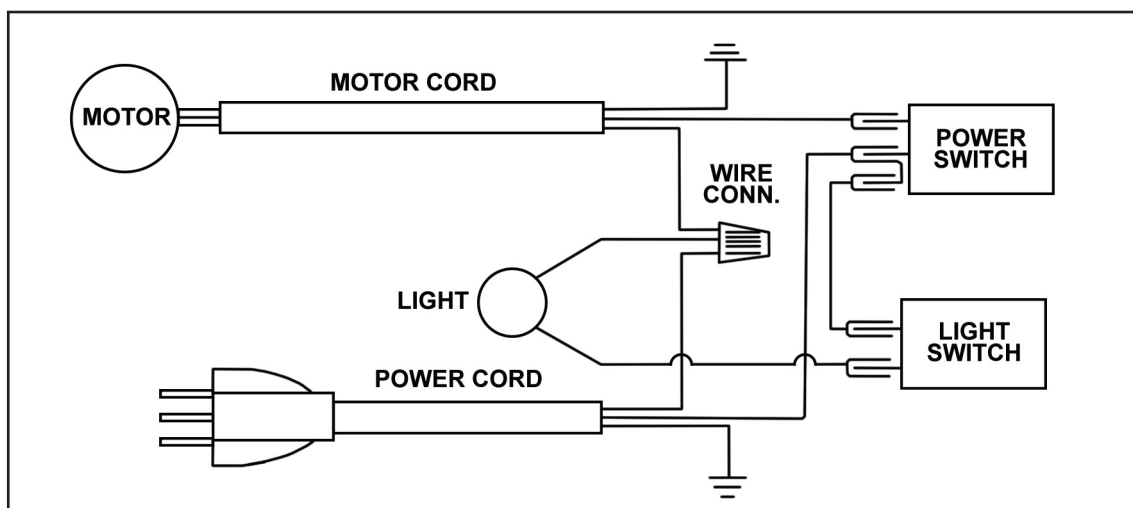

PARTS DIAGRAM & PARTS LIST

COLUMN & TABLE SHEET A

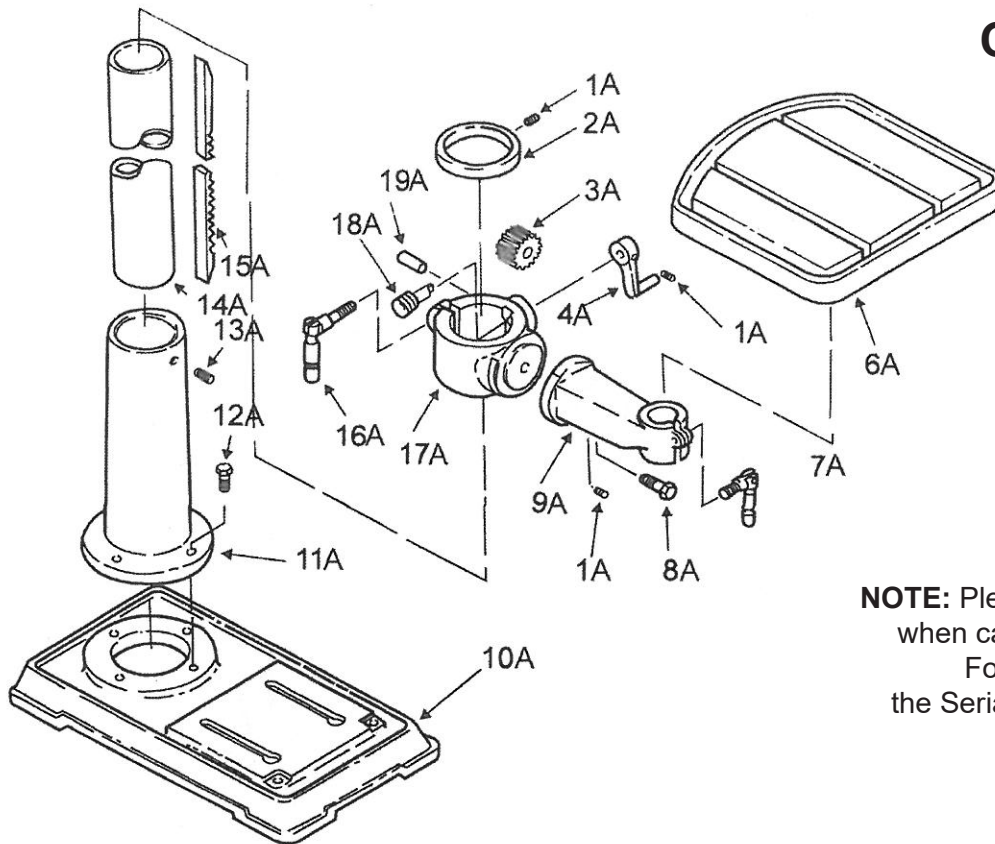

NOTE: Please reference the Part Number when calling for Replacement Parts. For Parts under Warranty, the Serial Number of your machine is required.

KEY NO.	DESCRIPTION	PART NO.	QTY.
1A	Hex. socket set screw M6X10	P30-230-1A	1
2A	Collar-Rack	P30-230-2A	1
3A	Gear-Helical	P30-230-3A	1
4A	Crank and Handle assembly	P30-230-4A	1
6A	Table	P30-230-6A	1
7A	Clamp-Table	P30-230-7A	1
8A	Hex. head screw M16X35	P30-230-8A	1
9A	Arm-table with scale	P30-230-9A	1
10A	Base	P30-230-10A	1
11A	Support Column	P30-230-11A	1
12A	Hex. head screw M10X40	P30-230-12A	1
13A	Hex. socket set screw M10X12	P30-230-13A	1
14A	Tube column	P30-230-14A	1
15A	Rack	P30-230-15A	1
16A	Clamp-column	P30-230-16A	1
17A	Support-Table with indicator	P30-230-17A	1
18A	Worm-Elevation	P30-230-18A	1
19A	Pin-gear	P30-230-19A	1

PARTS DIAGRAM & PARTS LIST

SPINDLE ASSEMBLY SHEET B

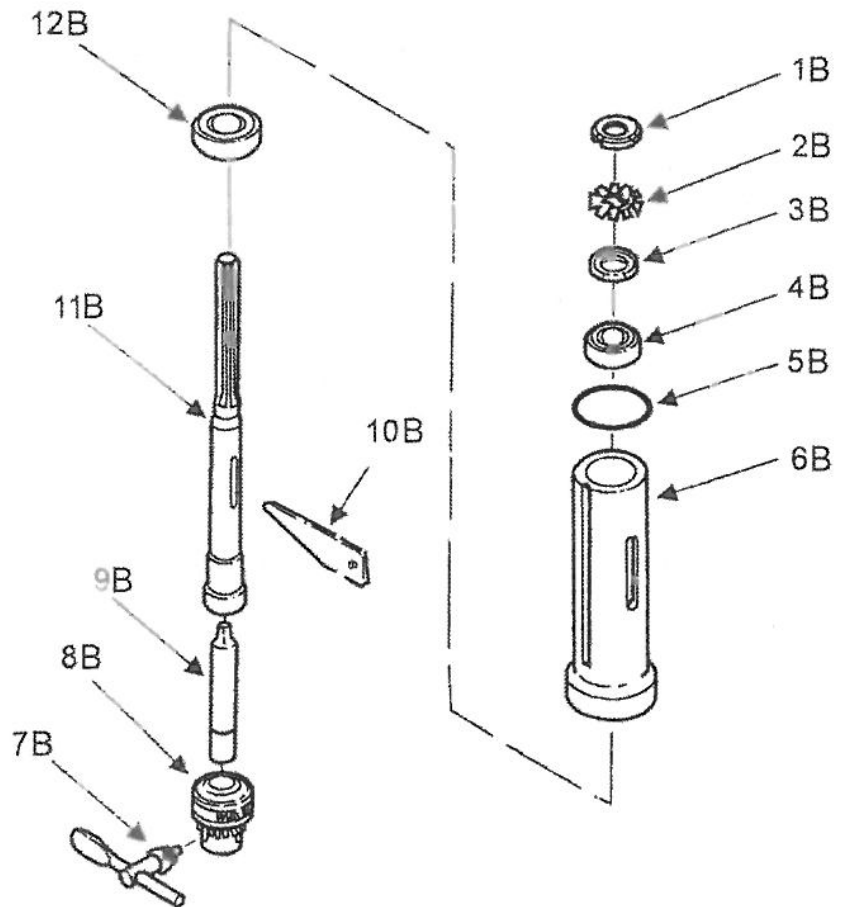

NOTE: Please reference the Part Number when calling for Replacement Parts. For Parts under Warranty, the Serial Number of your machine is required.

KEY NO.	DESCRIPTION	PART NO.	QTY.
1B	Nut-Lock	P30-230-1B	2
2B	Ring-Locking	P30-230-2B	1
3B	Washer	P30-230-3B	1
4B	Bearing-Ball 17mm	P30-230-4B	1
5B	Washer-Rubber	P30-230-5B	1
6B	Tube-Quill	P30-230-6B	1
7B	Key-Chuck	P30-230-7B	1
8B	Chuck	P30-230-8B	1
9B	Arbor	P30-230-9B	1
10B	Key-Drift	P30-230-10B	1
11B	Spindle	P30-230-11B	1
12B	Bearing-Ball 25mm	P30-230-12B	1

PARTS DIAGRAM & PARTS LIST

PULLEY & DRIVE ASSEMBLY SHEET C

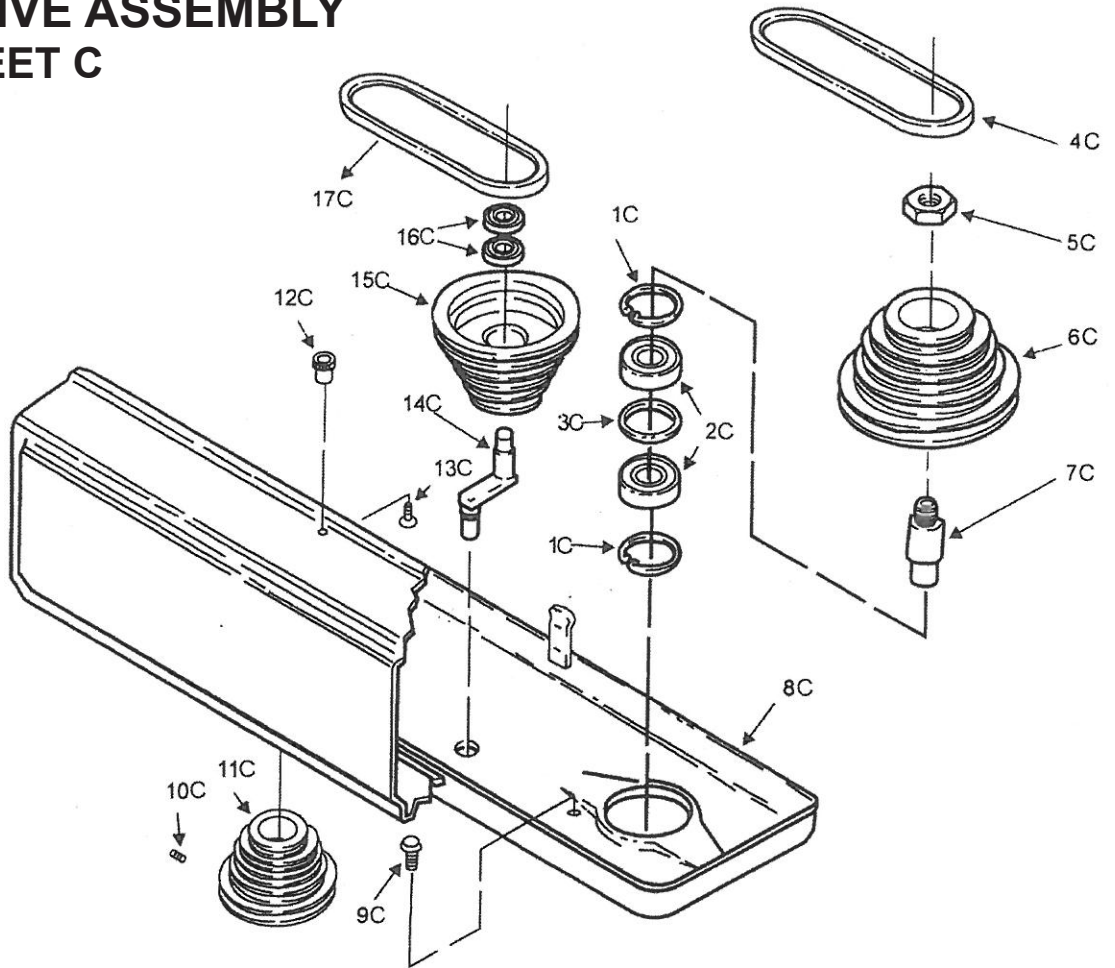

NOTE: Please reference the Part Number when calling for Replacement Parts. For Parts under Warranty, the Serial Number of your machine is required.

KEY NO.	DESCRIPTION	PART NO.	QTY.
1C	Ring-Retaining	P30-230-1C	1
2C	Bearing Ball 25mm	P30-230-2C	2
3C	Spacer-Bearing	P30-230-3C	1
4C	Belt-"V" 1/2X29	P30-230-4C	1
5C	Nut-Pulley	P30-230-5C	1
6C	Pulley-Spindle	P30-230-6C	1
7C	Insert-Pulley	P30-230-7C	1
8C	Guard-Pulley with Labels	P30-230-8C	1
9C	Screw-RD HD Washer M6X12	P30-230-9C	4
10C	Screw-Set M10X1.5-12 M10X12	P30-230-10C	1
11C	Pulley-Motor	P30-230-11C	1
12C	Knob	P30-230-12C	1
13C	Screw-Pan HD M5X12	P30-230-13C	1
14C	Pivot-Idler	P30-230-14C	1
15C	Pulley-Center	P30-230-15C	1
16C	Bearing Ball 15mm	P30-230-16C	2
17C	Belt-"V" 1/2X27	P30-230-17C	1

HEAD, MOTOR & CONTROLS SHEET D

PARTS DIAGRAM

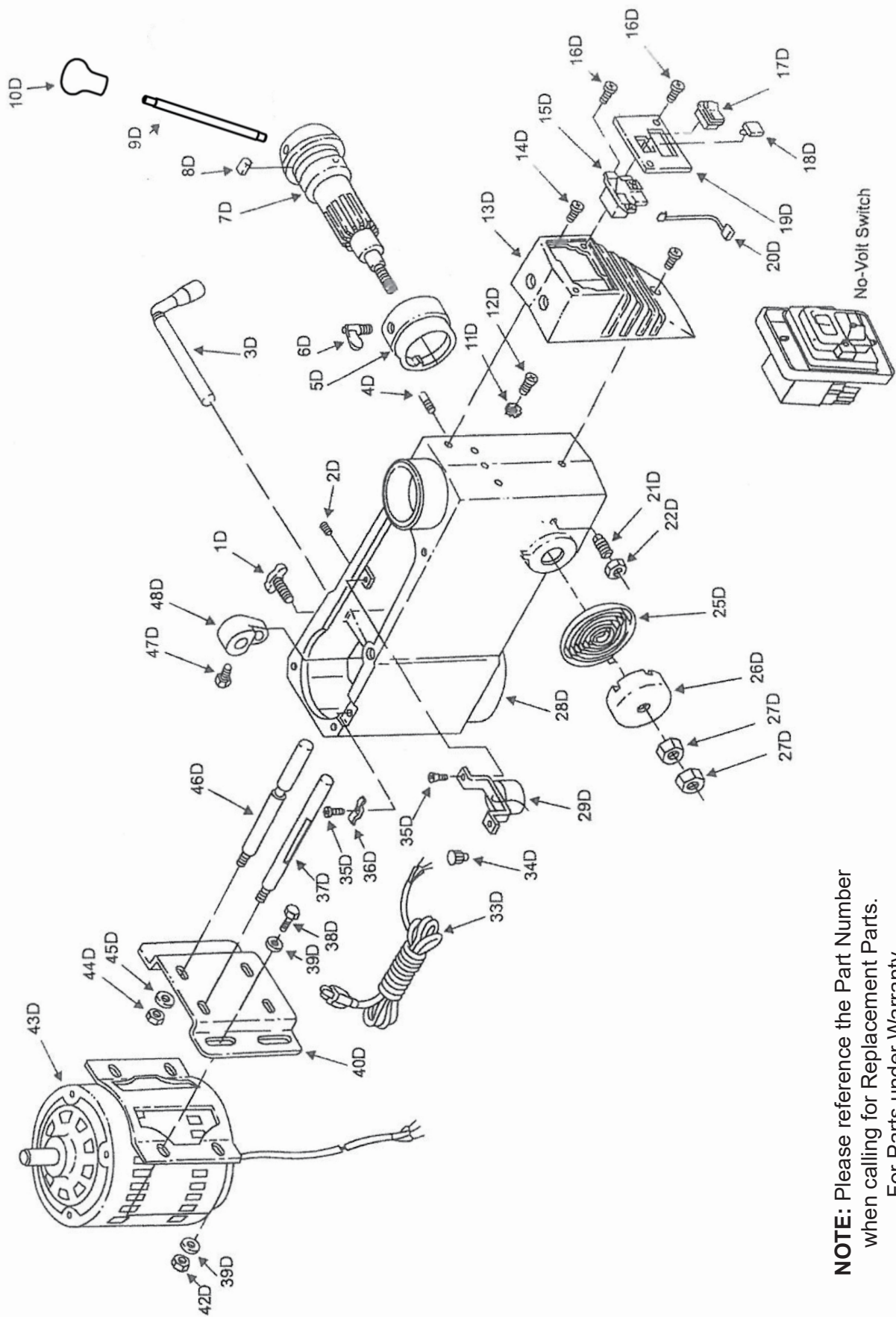

NOTE: Please reference the Part Number when calling for Replacement Parts. For Parts under Warranty, the Serial Number of your machine is required.

PARTS LIST

KEY NO.	DESCRIPTION	PART NO.	QTY.
1D	Knob-Motor Adjusting	P30-230-1D	2
2D	Screw-Socket Set M10X1.5-12	P30-230-2D	2
3D	Handle-Belt Tension	P30-230-3D	1
4D	Pin-Stop	P30-230-4D	1
5D	Ring-Depth Stop with Scale	P30-230-5D	1
6D	Lock-Depth Screw	P30-230-6D	1
7D	Hub	P30-230-7D	1
8D	Guide Scale	P30-230-8D	1
9D	Feed Handles	P30-230-9D	3
10D	Knob	P30-230-10D	3
11D	Lock washer-EXT M5	P30-230-11D	2
12D	Screw-Pan HD M5X8	P30-230-12D	6
13D	Box Switch	P30-230-13D	1
14D	Screw-Pan HD M5X16	P30-230-14D	2
15D	Switch-Locking	P30-230-15D	1
16D	Screw-Pan HD M4.2x9D5	P30-230-16D	3
17D	Switch-Rocker	P30-230-17D	1
18D	Key-Switch	P30-230-18D	1
19D	Cover-Switch Plate	P30-230-19D	1
20D	Lead-Assembly 3	P30-230-20D	1
21D	Screw-Set Special	P30-230-21D	1
22D	Nut-Hex M10X1.5	P30-230-22D	1
25D	Spring-Torsion	P30-230-25D	1
26D	Cap-Spring	P30-230-26D	1
27D	Nut-Hex M12X8	P30-230-27D	2
28D	Head with Pointer and Trim	P30-230-28D	1
29D	Socket-Bulb Assembly	P30-230-29D	1
33D	Cord-Power with Plug	P30-230-33D	1
34D	Connector-Wire	P30-230-34D	1
35D	Screw-Pan HD. M5X16	P30-230-35D	1
36D	Clamp-Cord	P30-230-36D	1
37D	Support-Motor bracket	P30-230-37D	2
38D	Screw-Hex HD M8X20	P30-230-38D	4
39D	Washer 8	P30-230-39D	8
40D	Mount-Motor	P30-230-40D	1
42D	Nut-Hex M8	P30-230-42D	4
43D	Motor	P30-230-43D	1
44D	Nut-Hex M12	P30-230-44D	2
45D	Lockwasher 1/2	P30-230-45D	2
46D	Support-Motor Bracket	P30-230-46D	1
47D	Screw Hex HD M8X16	P30-230-47D	1
48D	Lever-Adjusting	P30-230-48D	1

TROUBLESHOOTING

⚠ WARNING FOR SAFETY, ALWAYS TURN OFF AND UNPLUG THE MACHINE BEFORE CARRYING OUT ANY TROUBLESHOOTING.

TROUBLE	PROBABLE CAUSE	REMEDY
Noisy Operation	<ol style="list-style-type: none"> 1. Incorrect belt tension. 2. Dry Spindle. 3. Loose spindle pulley. 4. Loose motor pulley. 	<ol style="list-style-type: none"> 1. Adjust tension. 2. Lubricate spindle. 3. Checking tightness of retaining nut on pulley and tighten if necessary. 4. Tighten set screws in pulleys.
Drill Bit Burns Material	<ol style="list-style-type: none"> 1. Incorrect speed. 2. Chips not coming out of hole. 3. Dull drill bit. 4. Feeding too slow. 5. Not Lubricated 	<ol style="list-style-type: none"> 1. Change speed. 2. Retract drill bit frequently to clear chips. 3. Resharpen drill bit. 4. Increase the speed. 5. Lubricate drill bit.
Drill bit leads off, hole not round.	<ol style="list-style-type: none"> 1. Hard grain in wood or lengths of cutting lips and/ or angles not equal. 2. Bent drill bit. 	<ol style="list-style-type: none"> 1. Resharpen drill bit correctly. 2. Replace drill bit.
Wood splinters on underside of workpiece.	<ol style="list-style-type: none"> 1. No "back up material" under workpiece. 	<ol style="list-style-type: none"> 1. Use "back-up material"
Wood piece pulled loose from hands.	<ol style="list-style-type: none"> 1. Not supported or clamped properly. 	<ol style="list-style-type: none"> 1. Support workpiece or clamp it.
Drill bit binds in workpiece.	<ol style="list-style-type: none"> 1. Workpiece pinching drill bit or excessive feed pressure. 2. Improper belt tension. 	<ol style="list-style-type: none"> 1. Support workpiece or clamp it. 2. Adjust belt tension.
Excessive drill bit runout or wobble.	<ol style="list-style-type: none"> 1. Bent drill bit. 2. Worn spindle bearings. 3. Drill bit not properly installed in chuck. 4. Chuck not properly installed. 	<ol style="list-style-type: none"> 1. Use a straight drill bit. 2. Replace bearings. 3. Install drill bit properly. 4. Install chuck properly.
Quill Returns too slow or too fast.	<ol style="list-style-type: none"> 1. Spring has improper tension. 	<ol style="list-style-type: none"> 1. Adjust spring tension.
Chuck will not stay attached to spindle, it falls off when trying to install it.	<ol style="list-style-type: none"> 1. Dirty, grease, or oil on the tapered inside surface of chuck or on the spindle's tapered surface. 	<ol style="list-style-type: none"> 1. Using a household detergent, clean the tapered surface of the chuck and spindle to remove all dirt, grease and oil.

ACCESSORIES & WARRANTY

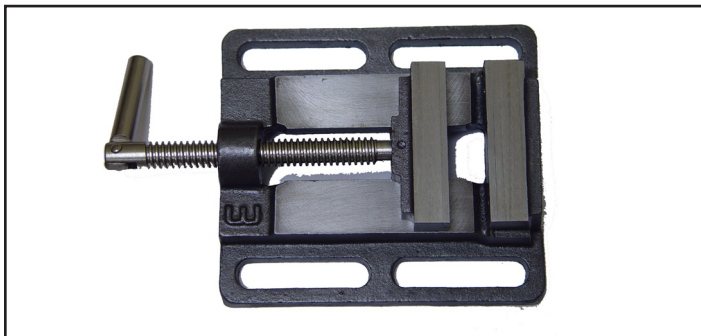

	Approximate Sizes	JAWS L x W	Jaws Open
93-010	3" Vise	3" x 13/16"	3-1/4"
93-020	4" Vise	4" x 15/16"	4-1/4"
93-030	5" Vise	5" x 7/8"	5"
93-040	6" Vise	6" x 1"	6"

All metal construction with side slots for mounting on drill press tables. Large toggle handles for fast adjusting of the jaws. Machined base and jaws to maintain table flatness and solid work support.

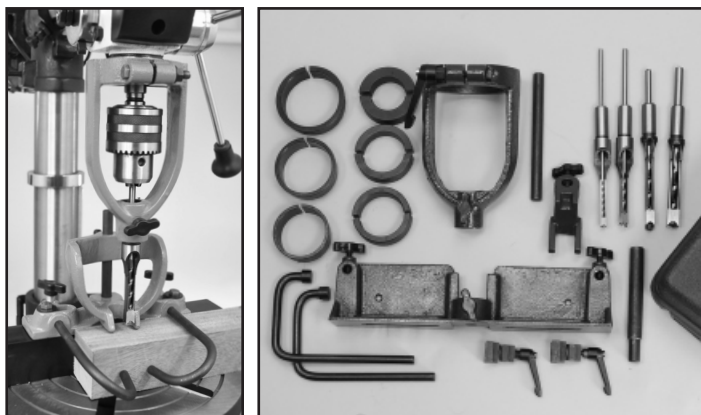

29-202 Mortising Attachment Kit

The Mortising Attachment converts your Drill Press in to an accurate mortising machine. It is ideal for drilling square holes for mortise & tenon joints that are commonly used in furniture, cabinets, sash, pattern shops and other woodworking plants.

The Mortising Attachment Kit can be installed on most any drill press with a collar size of: 40mm, 48mm, 50.8mm, 60mm, 66mm or 75mm. Kit includes yoke, collar adapters, fence, hold downs, 4 chisels & bits (1/4", 5/16", 3/8" 1/2") and plastic storage case.

RIKON

POWER TOOLS®

5-Year Limited Warranty

RIKON Power Tools Inc. ("Seller") warrants to only the original retail consumer/purchaser of our products that each product be free from defects in materials and workmanship for a period of five (5) years from the date the product was purchased at retail. This warranty may not be transferred.

This warranty does not apply to defects due directly or indirectly to misuse, abuse, negligence, accidents, repairs, alterations, lack of maintenance or normal wear and tear. Under no circumstances will Seller be liable for incidental or consequential damages resulting from defective products. All other warranties, expressed or implied, whether of merchantability, fitness for purpose, or otherwise are expressly disclaimed by Seller. This five-year warranty does not cover products used for commercial, industrial or educational purposes. The warranty term for these claims will be limited to a two-year period.

This limited warranty does not apply to accessory items such as blades, drill bits, sanding discs, grinding wheels, belts, guide bearings and other related items.

Seller shall in no event be liable for death, injuries to persons or property, or for incidental, contingent, special, or consequential damages arising from the use of our products.

To take advantage of this warranty, proof of purchase documentation must be provided which has the date of purchase and an explanation of the complaint.

The Seller reserves the right to effect at any time, without prior notice, those alterations to parts, fittings, and accessory equipment which they may deem necessary for any reason whatsoever.

To register your machine online, visit RIKON at www.rikontools.com/warranty

To take advantage of this warranty, or if you have any questions, please contact us at 877-884-5167 or email warranty@rikontools.com



For more information:
16 Progress Road
Billerica, MA 01821

877-884-5167 / 978-528-5380
techsupport@rikontools.com



LINK TO RIKON WEBSITE