

CAMaster



User Manual

Version 1.0 (3/15/2024) for all Centroid Machines

Contents

1	Terms and Conditions of Limited Warranty.....	5
2	Policies and Procedures	7
2.1	Part Return Policy	7
2.2	Service Policy.....	7
2.3	Shipping Policy	8
2.4	Installation and Setup	8
2.5	Technical Support	8
2.6	Training	9
3	General Information	10
3.1	Safety Symbols	10
3.2	Safety Guidelines	11
3.3	Work Area Guidelines	11
3.4	System Use and Care	11
3.5	Electrical Handling.....	12
3.6	Electrical and Mechanical Service.....	12
4	Machine Information	14
4.1	General Specifications.....	14
4.2	Equipment Descriptions.....	15
4.3	Equipment Handling	16
4.4	Equipment Positioning.....	17
4.5	Equipment Leveling.....	18
4.6	Computer Setup.....	19
4.7	Monitor Stand	19
4.7.1	Monitor Stand Setup.....	19
4.7.2	Monitor Stand Interface.....	20
4.8	Machine Setup	20
4.8.1	Electrical Connection	20
4.8.2	Compressed Air Connection.....	23
5	System Information.....	25
5.1	Hickory Controller	25

5.2	Acorn Controller.....	25
5.3	CNC12.....	25
5.4	System Integration.....	26
6	CNC12 Screen.....	27
6.1	Layout.....	27
6.2	Main Screen	28
6.2.1	Setup	29
6.2.2	Load.....	32
6.2.3	MDI.....	32
6.2.4	Run	33
6.2.5	CAM.....	34
6.2.6	Edit	35
6.2.7	Utility.....	35
6.2.8	Graph.....	36
6.2.9	Digitiz.....	38
6.2.10	Shut Down.....	38
6.3	Virtual Control Panel.....	38
6.3.1	Control Buttons.....	40
6.3.2	Function Buttons.....	41
6.3.3	Jog Buttons.....	50
6.3.4	Feedrate Override Buttons	51
6.3.5	Spindle Control Buttons	51
6.3.6	Reset Button	52
6.3.7	Tool Buttons.....	52
6.3.8	Hotkeys	56
7	Machine Operation	57
7.1	Tool Installation	57
7.2	Start-Up Procedure	58
7.3	Spoil Board Preparation	59
7.4	Standard Operating Procedure	60
7.4.1	Switch Calibration	60
7.4.2	Manual Tool Measuring	60

7.4.3	ATC Tool Change	61
7.4.4	FTC Mode Operation.....	61
7.4.5	Single Tool Operation.....	64
7.4.6	Oscillating Knife Mode	65
7.4.7	Tangential Knife Mode.....	66
7.4.8	Laser Engraver Mode	66
7.4.9	Camera Mode.....	67
7.4.10	Crosshair Laser Operation.....	68
7.5	Smoothing Setup.....	68
7.6	Shutdown Procedure	69
7.7	Maintenance	70
7.7.1	Maintenance Schedule.....	70
7.7.2	Manual Lubrication	71
7.7.3	Automatic Lubrication.....	72
7.7.4	Control Box.....	72
7.7.5	Dust & Debris Removal	73
8	Post-Processor Support.....	74
8.1	Supported Posts	74
8.1.1	Vectric Posts.....	74
8.1.2	Fusion 360 Posts	74
8.1.3	HSMWorks Posts.....	75
8.2	Other Posts.....	75
9	Supported GCode.....	76
9.1	G Codes	76
9.2	M Codes	81
9.3	Other Registers	85
10	Troubleshooting.....	87

1 Terms and Conditions of Limited Warranty

At CAMaster, Inc. (the "Company"), we take great pride in the quality of our products and carefully inspect and test our products prior to their sale.

Subject to the terms, conditions and limitations set forth herein, we, therefore, agree to correct any defects in our materials or workmanship which arise within one (1) year from the date of shipment from our factory of any new equipment, for all CAMaster Centroid machines. However, this warranty does not extend to the repair or replacement of parts, equipment, or machines whose failure is caused, in whole or in part, from normal wear and tear, misuse, abuse, negligence, or willful acts, either in installation or operation. Examples of such items that may be considered normal wear and tear are spindle bearings, tool holders, tooling, gas shocks, etc. In addition, this warranty does not extend to the repair or replacement of parts as part of adjustments or routine maintenance. This Limited Warranty will be rendered null and void if the machine, or any parts thereto, have been repaired or altered with parts and/or equipment not supplied or pre-approved by the Company. The Company further reserves the right to decline responsibility where installations, repairs, maintenance, or alterations have been improperly made or attempted by others.

This Limited Warranty applies only to such new equipment, machines and parts manufactured by the Company. Any parts, equipment, software, or machinery manufactured or supplied by other manufacturers shall be covered solely by the warranty, if any, of such manufacturer and not by the Company.

This warranty is transferable from the original Customer to another party if the equipment is sold via private sale before the end of the warranty period, provided that written notice thereof is provided to Company and this warranty is not void at the time of transfer. The transferee of this warranty will be subject to all terms and conditions of this Certificate.

If your account payment status is not kept current and satisfactory, all technical support, software support, machine operation and warranty obligations, including those set forth herein, will be suspended. Any and all machines, equipment or parts requiring repair or replacement under this Limited Warranty shall be sent to the Company F.O.B. Cartersville, Georgia. Should the purchaser fail to return to the Company the defective machine, equipment, or parts within ten (10) days of its receipt of any replacement, then the purchaser hereby expressly agrees to pay to the Company the full cost of such parts, equipment, and machine, as if new and in good working order, plus interest accruing until satisfied.

LIMITATIONS, DISCLAIMERS AND EXCLUSIONS: EXCEPT AS PROVIDED HEREIN, THERE ARE NO WARRANTIES, EXPRESS OR IMPLIED, INCLUDING ANY WARRANTY OF MERCHANTABILITY OR FITNESS FOR A PARTICULAR PURPOSE. THE MAXIMUM LIABILITY OF THE COMPANY ARISING FROM ANY WARRANTY CLAIM SHALL BE LIMITED TO THE REPAIR OR REPLACEMENT OF THE COMPONENTS PROVEN DEFECTIVE. UNDER NO CIRCUMSTANCES SHALL THE COMPANY BE LIABLE OR RESPONSIBLE FOR ANY INCIDENTAL, SPECIAL, INDIRECT OR CONSEQUENTIAL DAMAGES, INCLUDING ANY CLAIMS FOR ECONOMIC LOSS, LOSS OF PRODUCTION OR MATERIALS, PROPERTY DAMAGE, PRODUCT LIABILITY, PERSONAL INJURY, OR ANY OTHER CLAIM BY THE PURCHASER, ITS AGENTS, EMPLOYEES, INSURANCE CARRIERS, SUBROGATES, SUCCESSORS, ASSIGNS, OR THIRD PARTIES ARISING OUT OF THE USE OF THE PRODUCTS EXCEPT AS EXPRESSLY PROVIDED HEREIN.

GOVERNING LAW, ARBITRATION AND FORUM SELECTION: This Limited Warranty and the parties' rights, obligations, and performance under it are governed by the laws of the State of Georgia excluding its choice of laws' provisions and excluding the Convention for the International Sale of Goods. Any controversy, claim or dispute arising out of or relating to this Limited Warranty shall be submitted to binding arbitration in Cartersville, Georgia in accordance with the rules and law of the State of Georgia, including the Revised Uniform Arbitration Act. The Parties shall each pay one-half of the costs and expenses of such arbitration and each shall separately pay its counsel fees and expenses unless otherwise ordered by the arbitrator(s).

2 Policies and Procedures

2.1 Part Return Policy

Before returning any parts in or out of warranty, the customer must first receive an authorization number and packing instructions from CAMaster. No claim will be allowed, nor credit given for parts returned without such authorization. Proper packaging and insurance for shipping is solely the responsibility of the customer. Upon receiving approval from CAMaster, the parts should be returned along with a statement describing the problem or defect with the CAMaster part with shipping prepaid. If, upon examination by CAMaster, a warranted defect exists, the product will be repaired or replaced at no charge and returned, prepaid, to the customer. Return will be by common carrier (e.g. UPS). Should the need for rapid, next-day, or any other special shipping arise, this will be at the customer's expense, not that of CAMaster's. Should an out-of-warranty situation exist, the customer shall be notified of any repair cost. At such time, the customer must pay the specified amount to cover the repair cost or authorize the return shipping of product as-is to the customer.

Any defective part must be returned to CAMaster within 5 business days after receipt of the replacement part. If the part is not returned within this time frame, CAMaster will invoice the customer the full retail cost of the part as determined by CAMaster. Any part returned to CAMaster must have adequate packaging to ensure no damage is received during shipping. In the event the part is determined to be damaged due to lack of maintenance, cleaning, or misuse/abuse, the customer will be responsible for the cost to replace the part, plus all related shipping charges.

Parts, under warranty, are shipped at CAMaster's cost either by common carrier, UPS ground service, or a similar method. UPS Ground is our standard method of shipment.

Technical support to install replacement parts is primarily provided by phone, email, or our Online Virtual Technician. If deemed necessary by CAMaster, a technician will be available to travel to the customer's facility.

2.2 Service Policy

Repairs are ordinarily done at the CAMaster facility in Cartersville, GA where all necessary instrumentation is available. Service equipment is difficult to transport, and thereby limits these services to be performed at the discretion of CAMaster. Should services be required and provided at the sole discretion of CAMaster, any and all relevant expenses incurred, including transportation, travel time, subsistence costs, and prevailing cost per hour (8 hour

minimum) are the responsibility of the customer. For more information, please refer to the Technical Support section of this manual.

2.3 Shipping Policy

CAMaster ships all machines from the CAMaster facility in Cartersville, GA. All shipments via freight lines (land, sea, or air) will be by a CAMaster appointed carrier. Customers can also pick the machine up from the CAMaster facility. Tarp and wrap charges will apply where applicable.

Upon delivery to the agreed customer location, it is solely the responsibility of the customer to inspect the shipment for any damage incurred during transport. Damage to any shipment must be noted on the bill of lading at the time of delivery. If damage is not noted on the Bill of Lading at the time of delivery, CAMaster is not responsible for damages occurring during shipment.

2.4 Installation and Setup

The CNC system will be tested and working properly prior to shipment. The customer will be responsible for installation of the machine and any accessories. CNC system and Software training are not included in the installation and setup. Upon delivery of the product to customer location, the customer is responsible for (1) removal of product from carrier's vehicle, (2) moving of product to its desired working location, and (3) final system assembly as required. The customer shall be solely responsible for electricity supplied to the CNC system from a service disconnect breaker.

The customer is responsible for meeting any applicable electrical and other codes.

2.5 Technical Support

CAMaster provides technical support service and assistance for its customers by (1) remote technician via internet, (2) telephone, (3) email, or (4) on-site technician. Technical support is no substitute for CNC system, or software training that is purchased separately by the customer. Technical support is provided at no charge to the customer for diagnosing and assisting in the remedy (1) of mechanical problems, (2) of electrical problems, and (3) of preventative maintenance issues, up to 1 hour per incident for any problem arising with CAMaster products which are covered by product limited warranty. The customer will be charged if technical support or assistance is required and the problem is not covered by the product's limited warranty. For technical service by telephone, the customer will be required to provide information about the CAMaster product and the problem. The technician will ask

questions concerning: (1) Nature of problem, (2) age of product or system, and (3) type of product.

Customers in need of technical service or assistance on a product or system that is not covered by the limited warranty will be required to provide the technician with a valid credit card number to cover technical support or assistance service charges. The customer is responsible for time and travel expenses for in-person support, please call for the current pricing.

2.6 Training

CAMaster offers its customers training on all CAMaster CNC systems and Software. For pricing, contact CAMaster Technical Support by email at support@camaster.com or by phone at 770-334-2144.

3 General Information

This manual has been prepared by the technical staff of CAMaster exclusively for its customers and contains reserved information. Therefore, any partial or total reproduction and/or disclosure to third parties of the content herein is strictly prohibited without the prior written consent of CAMaster. This manual is supplied as an integral part of the CNC system and constitutes, at the time of printing, the latest edition of documentation pertaining to the product.

This manual is to be used by suitably trained personnel only. The information contained in this manual offers no guarantee against risk. The use of the content of this manual is the sole responsibility of the user. CAMaster cannot be held responsible or liable for any damage or injury resulting from incorrect use of this document.

This manual describes the procedures and correct installation of the CNC system. In the case of conflict between these instructions and safety, electrical, or other standards/ codes, please contact CAMaster for any corrective and or adaptive measures. Under no circumstances can the instructions contained in this manual substitute technical, electrical, or safety standards/codes.

IT IS THE SOLE RESPONSIBILITY OF THE CNC SYSTEM USER TO THOROUGHLY READ AND UNDERSTAND THIS AND ALL DOCUMENTATION SUPPLIED WITH THE CNC SYSTEM IN ORDER TO AVOID ANY INCORRECT OR DANGEROUS PROCEDURES OR OPERATIONS.

3.1 Safety Symbols

Important instructions or precautions are marked with the following symbols:

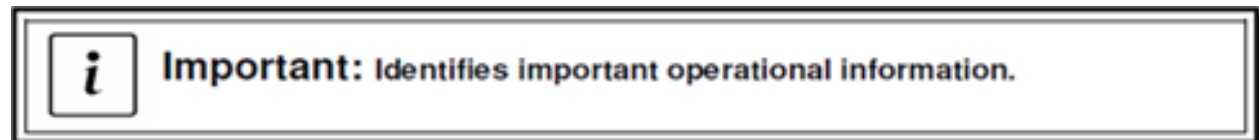
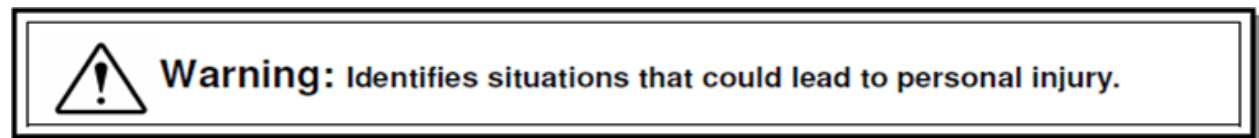

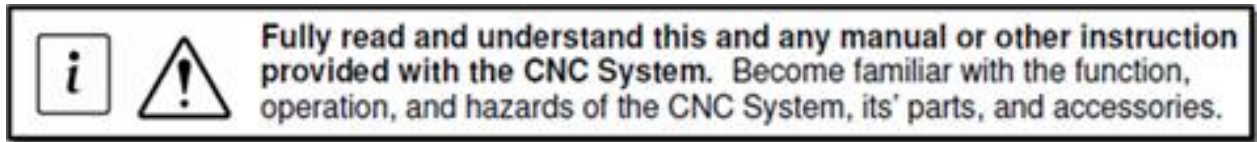

3.2 Safety Guidelines

Strictly adhere to the following safety guidelines to ensure the personal safety of any operators and/or bystanders:

- Only qualified personnel should operate the CNC system.
- Stand clear of moving machinery.
- Never run CNC equipment unattended.
- Stay alert, watch what you are doing, and use good sense when operating the CNC system.
- Do not use the CNC system while tired or under the influence of drugs, alcohol, or medication.
- Keep long hair, clothing, jewelry, and gloves away from moving parts.
- Always keep body parts away from cutting heads.
- Always use personal protective equipment (PPE) as required by law including: safety glasses, hearing protection, dust or vapor protection, non-skid shoes, and hard hat.
- Remove collet wrenches before operating the CNC system.

3.3 Work Area Guidelines

Strictly adhere to the following work area guidelines to ensure the personal safety of any operators and/or bystanders:

- Keep the work area clean and well lit.
- Do not operate the CNC system in the presence of flammable liquids, gas, or dust.
- Keep bystanders, visitors, and children away while operating the CNC system.
- Remove unnecessary articles from work surface before operating the CNC system.
- Observe any caution or warning signs supplied with the CNC system.

3.4 System Use and Care

Strictly adhere to the following system use and care guidelines to ensure the personal safety of any operators and/or bystanders:

- Use clamps or other practical ways to firmly secure and support the work piece.
- Maintain the CNC system with care.
- Always use the tooling manufacturer's recommended cutting speeds and feed rates.
- Keep all cutting tools sharp and clean.
- Do not force a tool to operate in a manner in which it was not designed for.

- Always use the correct tool for the job.
- Check for misalignment or binding of moving parts and any other condition that may affect the system's safe operation.
- Always keep the CNC system controls clean and free from dirt, debris, grease, and oil.
- Always know the locations of any E-Stop(s) or other emergency features on the CNC system.

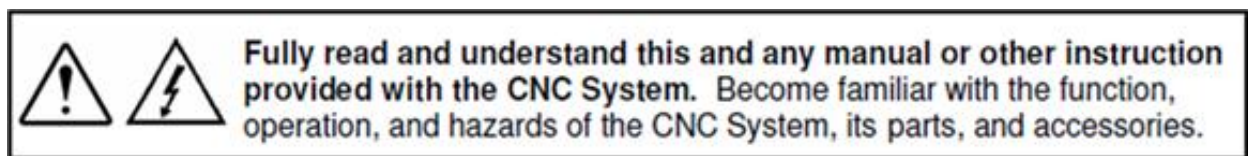
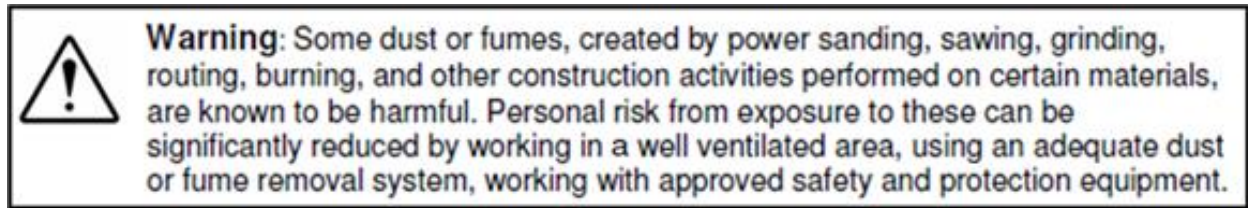

3.5 Electrical Handling

Strictly adhere to the following electrical handling guidelines to ensure the personal safety of any operators and/or bystanders:

- Any electrical work should be done by a qualified and licensed electrician.
- Always keep the system control box closed during operation.
- Always keep electrical guards and covers in place while power is supplied to the CNC system.
- Always disconnect power from the CNC system before performing any maintenance procedure.
- Always know the location of the electrical service disconnect breaker.
- Always keep cable and wire carriers clean from dust, dirt, debris, metal chips, oil, grease, water, and other materials or fluids.
- Check any connectors, plugs, or other electrical devices for proper connection before system operation.
- Do not operate the CNC system during electrical storms.

3.6 Electrical and Mechanical Service

Strictly adhere to the following electrical and mechanical service guidelines to ensure the personal safety of any operators and/or bystanders:

- Use only spare parts and accessories recommended by the manufacturer for your make and model.
- Repair or maintenance service must be performed only by trained and qualified service technicians.
- Do not modify or alter any mechanical or electrical part of the CNC system without prior instruction or authorization.



Warning: Care must be taken to not damage any exposed electrical cabling (or connector), compressed air fitting (or line), vacuum piping, dust collection, fume extraction hoses, or any other connection during loading, unloading, or relocation of CNC equipment. All electrical cables, compressed air lines, vacuum piping, dust collection, or fume extraction hoses must be disconnected before moving or relocating the CNC equipment.

4 Machine Information

The following information provides general information regarding the CAMaster Centroid machines and may have slight variations to your specific model. All specifications are for standard machines without optional features.

4.1 General Specifications

Stinger Specifications

Model Number	(Stinger I) SR-204	(Stinger II) SR-404	(Stinger III) SR-408
Cutting Area	25"x48"	49"x49"	49"x97"
Z Axis Clearance	5"	6"	6"
Overall Width	42"	67"	67"
Overall Length	72"	78"	126"
Max Height	40"	71"	71"
Weight w/o Options	550 lbs.	1750 lbs.	2200 lbs.

Panther Specifications

Model Number	PT-404	PT-408	PT-510
Cutting Area	49"x49"	49"x97"	61"x121"
Z Axis Clearance	10"	10"	10"
Overall Width	73.5"	73.5"	84.5"
Overall Length	94"	142"	166"
Max Height	95"	95"	95"
Weight w/o Options	2300 lbs.	2500 lbs.	3200 lbs.

Panther SignPro Specifications

Model Number	SP-404	SP-408	SP-510
Cutting Area	49"x49"	49"x97"	61"x121"
Z Axis Clearance	10"	10"	10"
Overall Width	73.5"	73.5"	84.5"
Overall Length	94"	142"	166"
Max Height	95"	95"	95"
Weight w/o Options	2350 lbs.	2550 lbs.	3250 lbs.

4.2 Equipment Descriptions

A CAMaster Stinger III with the Centroid controller is shown below. The features shown below are common features that many models have but may not be present on every model. Other CAMaster models equipped with the Centroid controller have similar main elements.





Equipment Descriptions:

- Control Box: Where the electrical system is located.
- Cutting Head: The main cutting spindle.
- Gantry: Tube that supports the X Axis motion.
- Vacuum Zone Controls: Manual vacuum zone control valves.
- X Axis Gear Rack: Helical gear rack along the X Axis.
- X Axis Gearbox: Location of X Axis gearbox.
- X Axis Linear Rail: Linear rail along the X Axis.
- Y Axis Gear Rack: Helical gear rack along the Y Axis.
- Y Axis Gearbox: Location of Y Axis gearbox.
- Y Axis Linear Rail: Linear rail along the Y Axis.
- Z Axis Head: Location of cutting spindle and any other heads.

4.3 Equipment Handling

Strictly adhere to the following equipment handling guidelines to ensure the personal safety of any operators and/or bystanders:

 **Warning:** Forklift or other equipment should be operated by trained, operating personnel only with good understanding of materials handling safety policy, and procedures. Any forklift or other equipment operator should be completely familiar with the equipment, its operation, and functions before unloading or moving any CNC system or equipment.

 **Important:** Use fork lift with fork extensions for unloading and moving the CNC equipment when required. See picture.

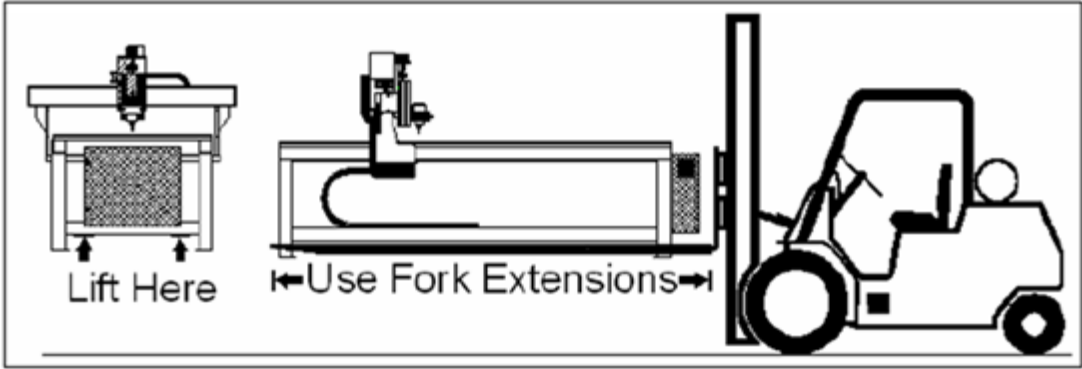

 **Warning:** CNC equipment may not be balanced. Use caution when moving or unloading so as not to damage CNC equipment, fork lift, or operator. See picture.

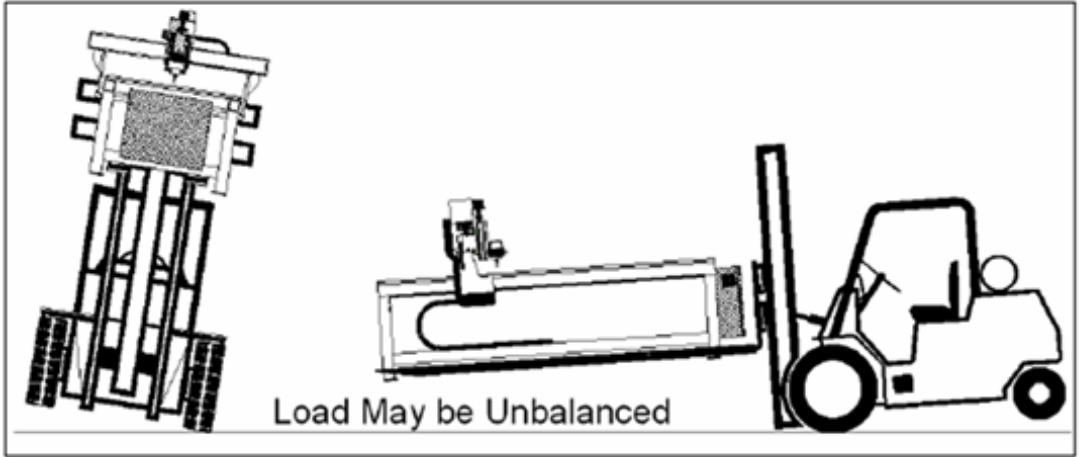

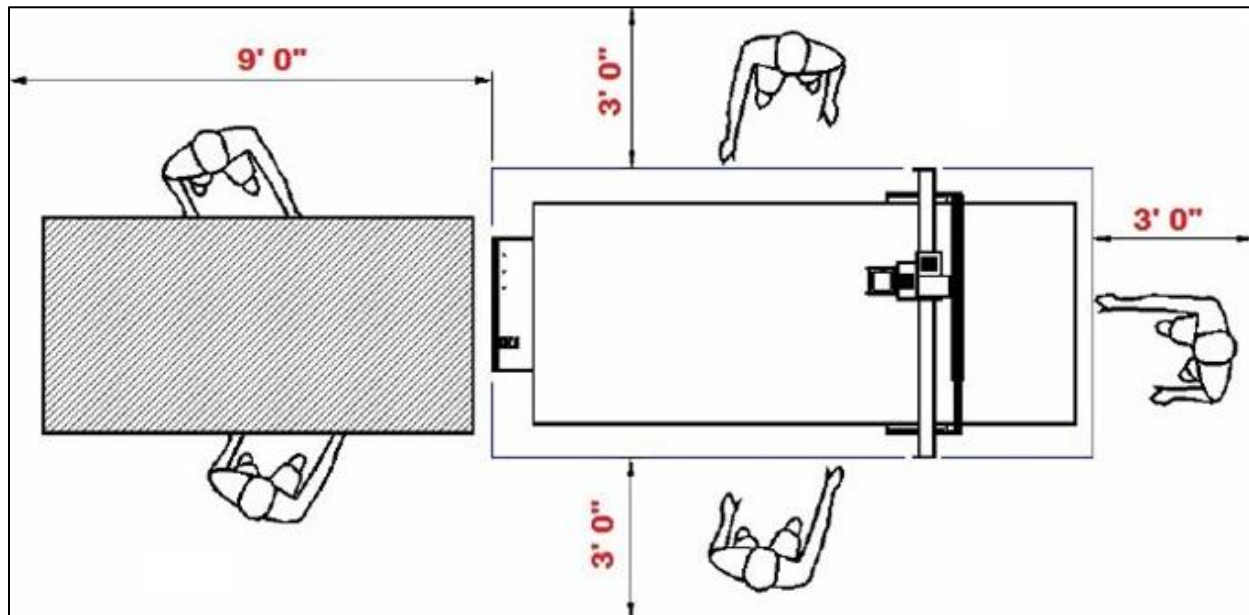

4.4 Equipment Positioning

The final position of the equipment will depend greatly on the customer's location. Allow for adequate spacing around the equipment for loading / unloading of materials, clamping material, and access to vacuum valves. CAMaster recommends an access path of at least 3 feet on three sides of the CNC Equipment and a material staging area extending 8 or 9 feet from the loading end of the equipment. If your application calls for large-sized material loading, please ensure that adequate spacing is allowed for safe material loading / unloading.



Final machine positioning or location of any equipment will be by customer decision.

 **Warning:** All moving parts must be clear of any obstruction to allow free movement at all times during system operation.

 **Warning:** Emergency stop should be accessible at all times during system operation. Do not cover, block, or obstruct access to the Emergency Stop or any system controls.

 **Warning:** Service disconnect should be accessible at all times during system operation. Service disconnect should never be locked in during system operation.

4.5 Equipment Leveling

The CNC table must be checked for level at several points across the tabletop surface using at least a 4-foot level. Shims of wood, steel, plastic, or rubber may be used to bring the table to level within 1/16th of an inch rise or fall in an 8-foot span. The table should have no teeter in any direction. All Cobra and Cobra Elite models come with leveling feet by default. For models that do not come with leveling feet, these may be purchased separately from CAMaster. Leveling feet may also be available from various machinery supply houses or hardware centers (e.g. McMaster Carr, Grainger, or Reed Tool).

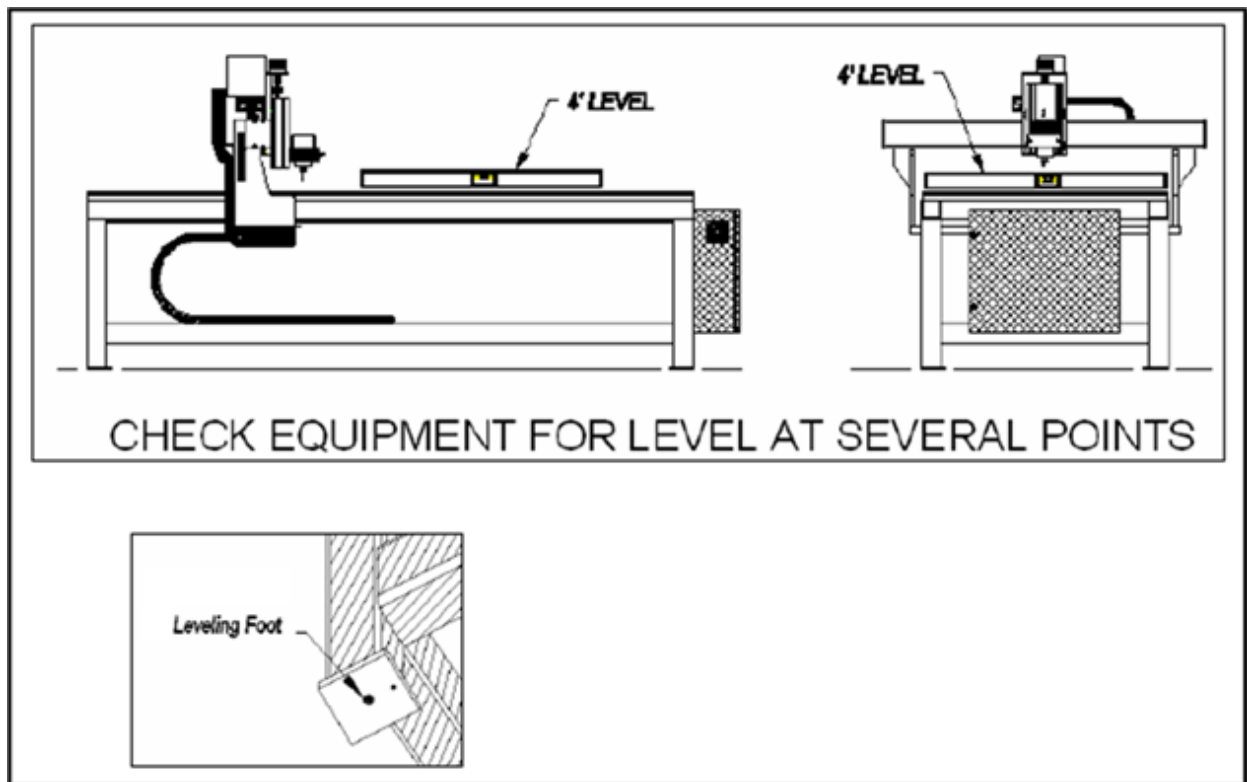

Important: Table top surface may not be true. Milling is normally required for truing the table's surface. Customer is responsible for table milling and truing on any of the equipment working surfaces.

4.6 Computer Setup

The computer included with the CNC system comes pre-configured with all required software to operate the CNC system. For systems without the optional monitor stand, follow the instructions below to set up the computer.

To set up the computer, unpack the PC unit from the box and connect it to the included power supply unit. Unpack the monitor from the box and connect the power and HDMI cable to the rear of the monitor. The HDMI cable connects to the back of the computer to one of the available ports. Unpack the keyboard and mouse and plug in their USB cables to the rear of the computer. Using the included shielded ethernet cable, connect the computer to the CNC system using the ethernet port in the rear of the computer and the port on the side of the CNC system's rear control box. Lastly, plug the power cables for both the computer and monitor into a power strip with a surge protector and power the computer and monitor on. Once powered on, the computer will open up the CNC12 software and attempt to automatically connect to the CNC system.

4.7 Monitor Stand

The monitor stand is an optional feature on some models of CNC systems. For CNC systems that come equipped with this feature, the monitor stand is part of the CNC system that requires an area for access by the system operator. CAMaster provides a stand for the keyboard and mouse that should be easily accessible and functional at all times during system operation. The control PC monitor should also be in plain view by the system operator. The control PC is located inside the monitor stand and can be accessed through the removable panel below the keyboard tray or behind the operator button panel on the front of the stand.

4.7.1 Monitor Stand Setup

To ensure safety for the monitor during shipping, the monitor is shipped detached from the monitor stand. Please attach the monitor to the stand using the hardware provided (see the picture below) and connect the power and HDMI cables into the rear of the monitor.

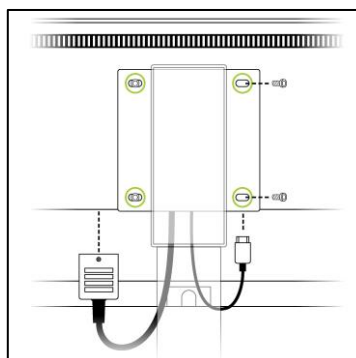

4.7.2 Monitor Stand Interface

The monitor stand contains power switches, USB ports, and an emergency stop to assist in the safe operation of the CNC system. The power switch on the left of the front panel has three positions: (Left) OFF - System Off, (Middle) COMP - PC Power On, and (3) CNC - CNC Power On. The front or side USB ports can be used to load programs onto the control PC but should not be used as a port for storage media for any active running CNC program. The emergency stop button is located on the right of the front panel and can be tripped by depressing the button. To release the emergency stop button after it has been depressed, rotate the button in a clockwise direction until the button springs free of the depressed position.

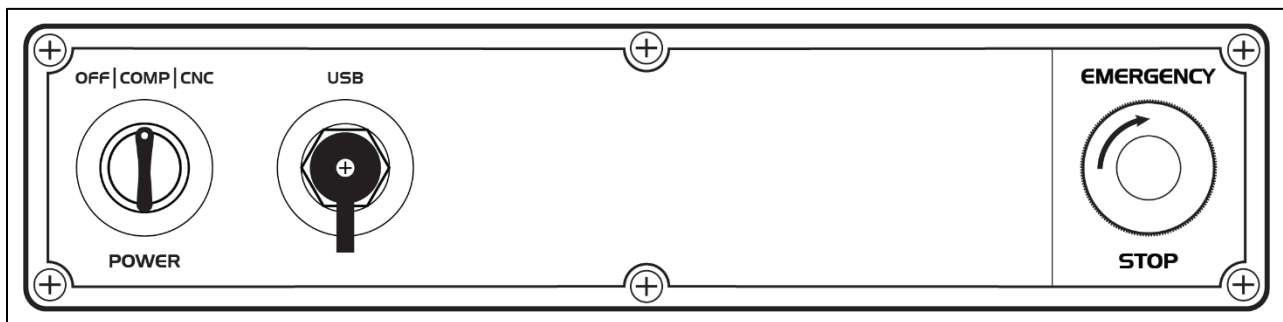







Optional buttons may be included on the monitor stand front panel if the CNC system is equipped with the relevant option. For laser engraver equipped systems, a laser power switch and reset button is included.

4.8 Machine Setup

The following sections show the proper electrical and compressed air setup for the CNC system.

4.8.1 Electrical Connection

Electrical power to the CNC system is provided by the customer. System power should be supplied through an easily accessible fused service disconnect switch or circuit breaker. All system accessories such as vacuum hold down, dust collection, etc. should also be connected with an adequate service disconnect or breaker. Control box power locations are provided for approximate power input locations. Input locations may vary slightly by model. Any equipment requiring 110V over 15A should be supplied by a fused service disconnect switch or breaker.

		Important: Any electrical work should be done by a qualified, licensed electrician.
		Important: All customer electrical inputs must meet NEC and local electrical codes.
		Important: The CNC system should be properly grounded.
	Warning: Service disconnect should be accessible at all times during system operation. Service disconnect should never be locked in during system operation.	

The table below represents the voltage and full load amperage usage based on the equipped spindle. This table can be used for all machine models except for Stinger I. For Stinger 1, please refer to the specific Stinger 1 table.

Electrical Requirements:

Spindle	Phase	Voltage	Amperage (FLA)	Circuit Breaker Size**
3.5 HP Router	Single	110V (Both)	12A & 12A	Qty 2: 1p 15A *
1.0 HP Manual	Single	110V (Both)	12A & 12A	Qty 2: 1p 15A *
1.3 HP Manual	Single	208-240V	16A	2p 20A
2.3 HP Manual	Single	208-240V	24A	2p 30A
3 HP ATC	Single	208-240V	24A	2p 30A
4 HP Manual	Single	208-240V	32A	2p 40A
5 HP Manual	Single	208-240V	32A	2p 40A
5 HP ATC	Single	208-240V	32A	2p 40A

Electrical Requirements: (Stinger 1 Only)

Spindle	Phase	Voltage	Amperage (FLA)	Circuit Breaker Size**
3.5 HP Router	Single	110V (Both)	12A & 12A	Qty 2: 1p 15A *
1.0 HP Manual	Single	110V (Both)	12A & 12A	Qty 2: 1p 15A *
1.3 HP Manual	Single	110V & 208-240V	12A & 12A	1p 15A & 2p 15A *
2.3 HP Manual	Single	110V & 208-240V	12A & 16A	1p 15A & 2p 20A *

* Power cables are already included.

** Check with your local electrical codes to confirm that the circuit breaker sizing is correct for your area.

Stinger I with Router or 1.0 HP Spindle Power Cable Plug: Quantity 2



Stinger I with 1.3 HP or 2.3 HP Spindle Power Cable Plug: Quantity 1 Each

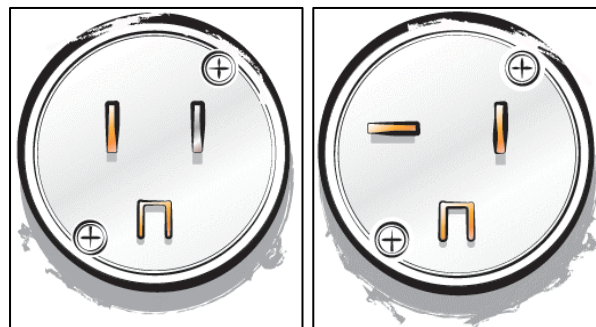

Stinger II/III with Router or 1.0 HP Spindle Power Cable Plug: Quantity 2



Stinger II/III Power-In Location: (1.3 HP models and up) Lower left-hand side inside control box

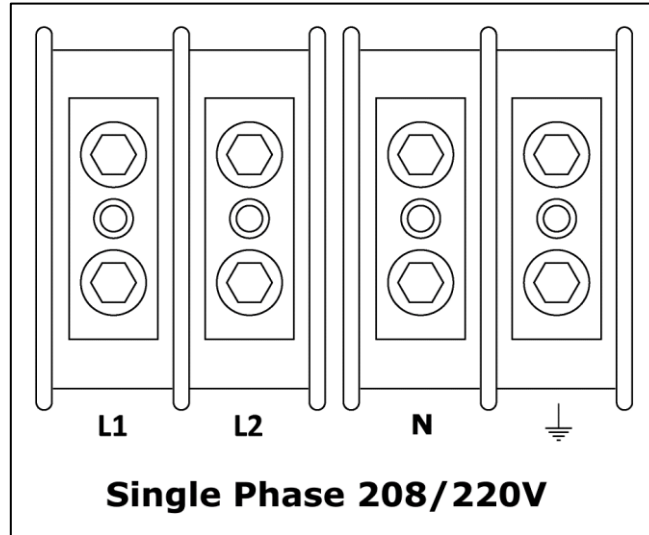

Panther/SignPro Power-In Location: (All models) Lower left-hand side inside control box

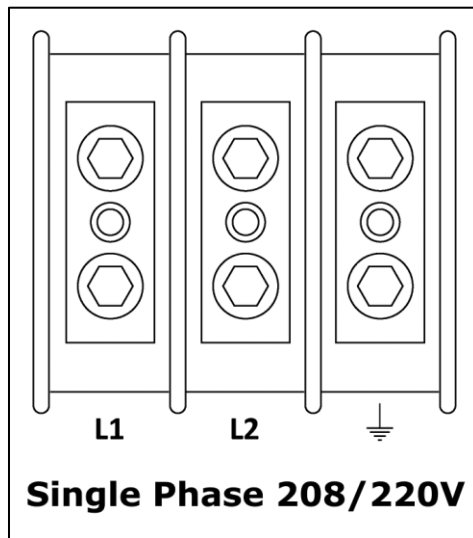

4.8.2 Compressed Air Connection

The CNC system's compressed air connection(s) are installed by the customer. Compressed air is required for all Panther and SignPro models, and all Stinger models with the counterbalance, mister, or 14W laser engraver option. Compressed air input(s) for all CNC systems are located on the back left table frame leg near the Control Box. The air supply connection(s) are made by ¼" male ARO type quick disconnect hose coupler. All compressed air going to the CNC system must be clean of debris and dry (oil free).

We recommend an air compressor that can provide a minimum of 90 PSI static air pressure for manual spindle equipped CNC systems or minimum 100 PSI with at least 10 CFM static air pressure for ATC spindle equipped CNC systems or 3 to 4 CFM static air pressure for manual spindle equipped CNC systems. Please do not supply more than 110 PSI to the CNC system.

Compressed Air Connection Example:



5 System Information

The Centroid controller ecosystem is a next-generation CNC Automation System that leaves everything else behind. This new system was developed in partnership with CENTROID Corporation, a global leader in CNC system control. Your CAMaster Centroid machine comes pre-configured and ready to run. The Panther and SignPro machines use the Hickory CNC control board, and the Stinger machines use the Acorn control board. Both control boards come equipped with an internal programmable logic controller (PLC).

5.1 Hickory Controller

The Hickory Controller comes equipped on all Panther and SignPro CNC systems. This device is the brain or core of the system that is responsible for all machine motion and behaviors. The controller communicates with the CNC12 software and the servo drives to provide a highly accurate and repeatable motion control system. This controller also handles all the communication and coordination of the spindle drive(s), (optional) laser control, and all inputs / outputs.

The Hickory Controller utilizes the EtherCAT industrial fieldbus protocol to communicate with the servo drives, allowing for a higher degree of communication between the devices on the network. This configuration allows for the use of absolute encoders that keep track of the position of each connected axis, even when the system is powered off.

5.2 Acorn Controller

The Acorn Controller comes equipped on all Stinger Series CNC systems. This device is the brain or core of the system that is responsible for all machine motion and behaviors. The controller communicates with the CNC12 software and the servo drives to provide a highly accurate and repeatable motion control system. This controller also handles all the communication and coordination of the spindle drive(s), (optional) laser control, and all inputs / outputs. All communication between the controller and the stepper or servo drives happens with digital IO and step/direction signals.

5.3 CNC12

CNC12 is Centroid's graphical user interface (GUI) software for both the Hickory and Acorn Controllers. This software allows the operator to interact with a highly customized user interface that simplifies the machine control while maintaining a high degree of precise motion control on the backend.

5.4 System Integration

The CAMaster CNC system is intended to be the pathway towards manufacturing the user's desired part. The way that the user can achieve this is by generating a GCode file compatible with the controller. All GCode files are to be generated by an external program to be then executed through the CNC12 GUI. For CAMaster Centroid compatible post-processors, please refer to the Post-Processor Support section of this manual.

It is important to note that the CAMaster CNC system running with the Centroid controller is not necessarily compatible with all of the features the Centroid controllers are capable of. Certain models of CNC systems are equipped with specific features designed with a specific purpose in mind and should not be changed, altered, or modified to act in a way in which it was not intended for. Users should refrain from sourcing any software updates from any place other than CAMaster, as the software versions included with the CNC system are configured for use only with the CAMaster CNC system and nowhere else. Any non-sanctioned updates may break some or all functionality of the CNC system and should be avoided.

6 CNC12 Screen

The CNC12 screen comes pre-configured from the CAMaster facility with all of the options that are included with your CNC system. This manual may contain graphics and layouts that differ from your specific setup and/or contain options that you may or may not have on your machine.

NOTE: If you are experiencing any technical difficulties with your machine’s VCP, please contact CAMaster Technical Support for assistance by phone at 770-334-2144 or by email at support@camaster.com.

6.1 Layout

Please refer to the following graphic for a breakdown of the general features of the CNC12 GUI:

CNC12 Screen Layout:

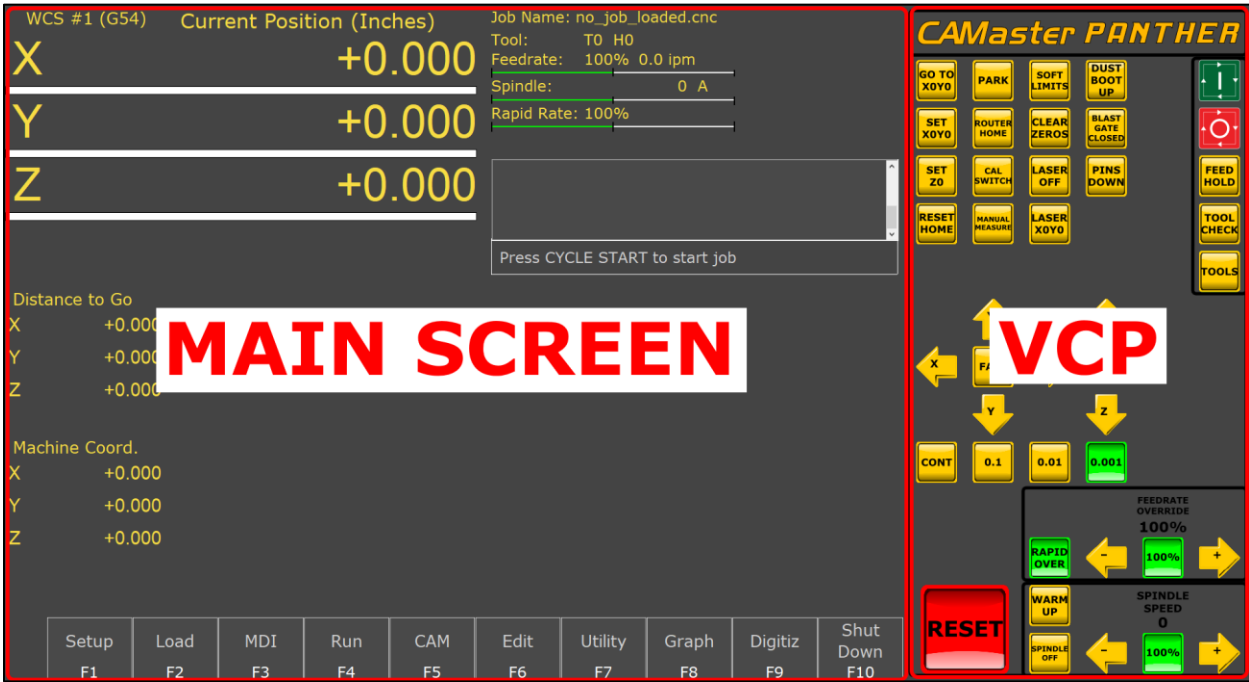

CNC12 Screen Labels:

- **Main Screen:** Contains the main CNC12 program and machine readouts.
- **Virtual Control Panel (VCP):** Contains the operator jog and function buttons.

6.2 Main Screen

The main screens section contains the major elements that are always available in all three operational modes.

Main Screen Layout:

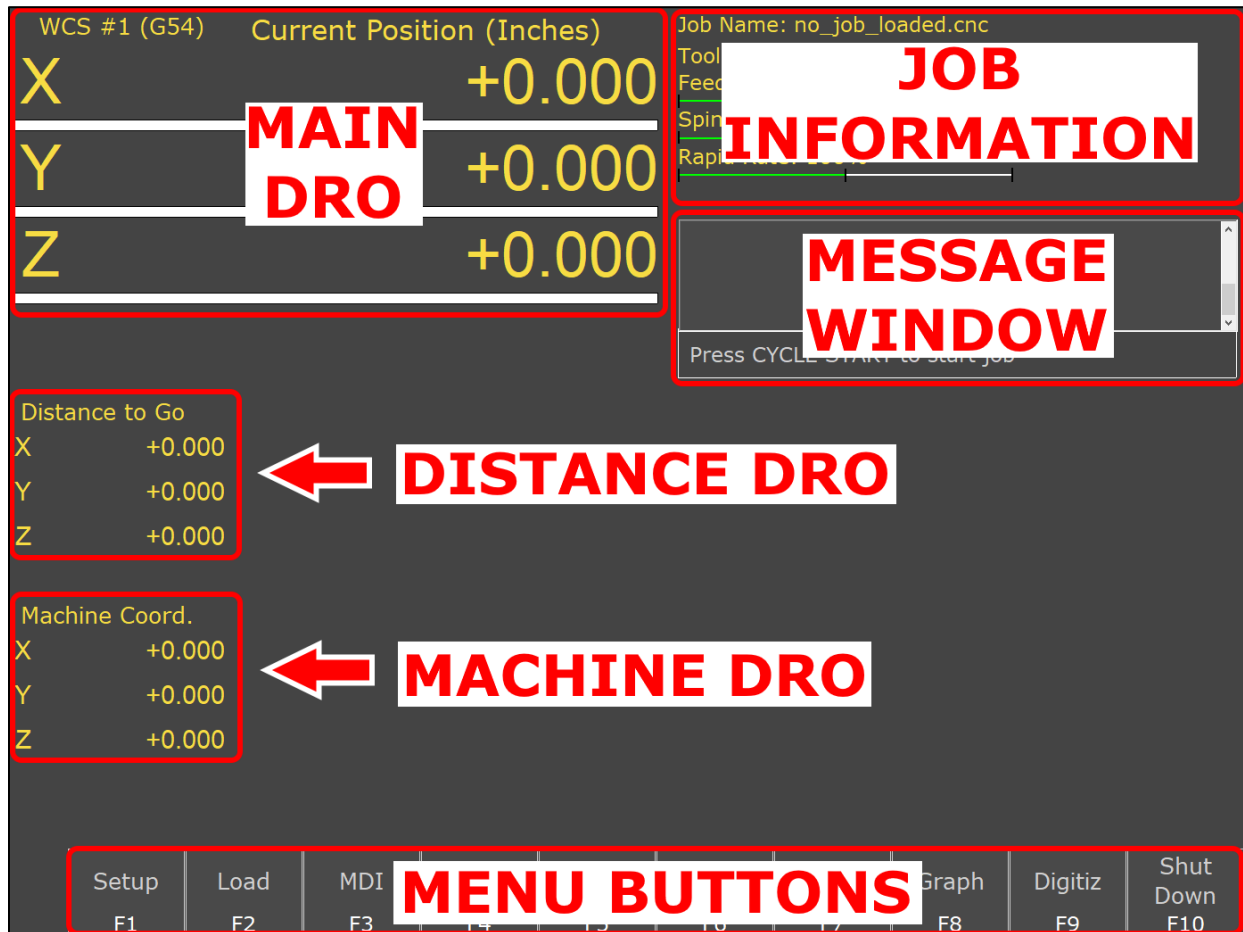

Main Screen Labels:

- **Main Digital Readout (DRO):** Displays your axes coordinates for your currently selected Work Coordinate System (WCS).
- **Distance Digital Readout (DRO):** Displays the remaining distance to go for each axis.
- **Machine Digital Readout (DRO):** Displays the axes coordinates in absolute machine coordinates without any local zero offset or height offset applied.
- **Job Information:** Displays important information for the loaded GCode file such as file name, current tool, feedrate, spindle speed, and rapid rate.
- **Message Window:** Displays important messages for the operator.
- **Menu Buttons:** Allows the operator to navigate the menus of CNC12 to perform specific tasks (See the sections below for additional menu screen information).

6.2.1 Setup

The setup button allows for operator configuration of the CNC system.

Setup Button (F1):

Setup F1	Load F2	MDI F3	Run F4	CAM F5	Edit F6	Utility F7	Graph F8	Digitiz F9	Shut Down F10
-------------	------------	-----------	-----------	-----------	------------	---------------	-------------	---------------	---------------------

Setup Screen:

X Esc	Part F1	Tool F2	Config F3	Feed F4	Smoothing Setup F8
----------	------------	------------	--------------	------------	--------------------------

Setup Buttons:

- **Part (F1):** Opens the Part screen, used to setup zeros with a touch probe. This functionality is not a commonly used feature on the CAMaster Centroid CNC system. Work origin setup is normally performed with the buttons on the VCP. Please refer to the Centroid Manual for more information about the Part screen.
- **Tool (F2):** Opens the Tool Setup screen, used to configure the tool library.
- **Config (F3):** Opens the Configuration menu. This functionality is password protected: 2269. **WARNING:** Changing any of the settings or parameters inside the config menus can break your machine. Please contact CAMaster Technical Support for assistance before making any changes.
- **Feed (F4):** Opens the Power Feed screen.
- **Smoothing Setup (F8):** Opens the Smoothing Setup Menu.

Tool Setup Screen:

X Esc	Offset Lib. F1	Tool Lib. F2	Tool Life F3
----------	----------------------	--------------------	--------------------

Tool Setup Buttons:

- **Offset Lib. (F1):** Opens the Tool Geometry Offset Library screen.
- **Tool Lib. (F2):** Opens the Tool Library screen.
- **Tool Life (F3):** Opens the Tool Life Management screen.

Tool Geometry Offset Library Screen:

Tool Geometry Offset Library

Height Offset	Diameter
H001 0.0000	D001 0.3750
H002 0.0000	D002 0.2500
H003 0.0000	D003 0.2500
H004 0.0000	D004 0.1875
H005 0.0000	D005 0.5000
H006 0.0000	D006 0.2010
H007 0.0000	D007 0.1360
H008 0.0000	D008 0.5000
H009 0.0000	D009 0.0200
H010 0.0000	D010 0.0200
H011 0.0000	D011 0.0200
H012 0.0000	D012 0.0500

Z Ref: 0.0000

Buttons: X Esc, Z Ref F1, Manual Measure F2, Auto Measure F3, +.001 F5, -.001 F6, Save F10

Tool Geometry Offset Buttons:

- **Z Ref (F1):** Click to set the Z reference. This feature is not normally used on the CAMaster Centroid CNC system. Z reference is normally set with the Cal Switch button on the VCP.
- **Manual Measure (F2):** Click to manually measure the selected tool. **WARNING:** This feature is not normally used on the CAMaster Centroid CNC system and can incorrectly set the tool height for the selected H register. Manually measuring a tool is normally performed with the Manual Measure button on the VCP.
- **Auto Measure (F3):** Click to automatically measure the selected tool. Pressing Cycle Start after clicking this button will command the CNC system to jog over the tool measure switch and start the measuring cycle.
- **+.001 (F5):** Click to offset the selected tool height offset by 0.001" in the positive direction.
- **-.001 (F6):** Click to offset the selected tool height offset by 0.001" in the negative direction.
- **Save (F10):** Click to save any changes made on the current screen.

Tool Library Screen:

Tool Library							
Tool	Bin	Ht.	Dia.	Coolant	Spindle	Speed	Description
T001	---	H001	D001	OFF	CW	10000	3/8" End Mill
T002	---	H002	D002	OFF	CW	8000	1/4" Center Drill
T003	---	H003	D003	OFF	CW	16000	1/4" End Mill
T004	---	H004	D004	OFF	CW	8000	3/16" Drill
T005	---	H005	D005	OFF	CW	16000	1/2" Chamfer
T006	---	H006	D006	OFF	CW	8000	#7 Drill
T007	---	H007	D007	OFF	CW	8000	#29 Drill
T008	---	H008	D008	OFF	CW	10000	1/2" End Mill
T009	---	H009	D009	OFF	CW	0	1" Knife Blade
T010	---	H010	D010	OFF	CW	0	2" Knife Blade
T011	---	H011	D011	OFF	CW	0	Utility Blade Knife
T012	---	H012	D012	OFF	CW	0	Creasing Wheel

Bin fields are locked.

Esc Export Lib... F4 Save F10

Note: The tool number, tool height number, and tool diameter number must match at all times. Additionally, the Spindle direction must be set to “CW” unless your CNC system comes equipped with the feature to turn the spindle in both directions. Lastly, the coolant feature must be set to “OFF” in this window. Coolant (mister or cold air gun) can still be utilized with certain tools but must be controlled via GCode from the post processor or via buttons on the VCP.

Tool Library Buttons:

- **Export Lib... (F4):** Click to open a system save file dialog to export the current tool library as a text file.
- **Save (F10):** Click to save any changes made on the current screen.

Tool Life Management Screen:

Tool Life Management							
Tool#	Type	Total Life	Used	Remaining	Units	Mode	Description
1	Drill	Off	0.0	0.0 (0%)	Inches	Manual	3/8" End Mill
2	Drill	Off	0.0	0.0 (0%)	Inches	Manual	1/4" Center Drill
3	Drill	Off	0.0	0.0 (0%)	Inches	Manual	1/4" End Mill
4	Drill	Off	0.0	0.0 (0%)	Inches	Manual	3/16" Drill
5	Drill	Off	0.0	0.0 (0%)	Inches	Manual	1/2" Chamfer
6	Drill	Off	0.0	0.0 (0%)	Inches	Manual	#7 Drill
7	Drill	Off	0.0	0.0 (0%)	Inches	Manual	#29 Drill
8	Drill	Off	0.0	0.0 (0%)	Inches	Manual	1/2" End Mill
9	Drill	Off	0.0	0.0 (0%)	Inches	Manual	1" Knife Blade
10	Drill	Off	0.0	0.0 (0%)	Inches	Manual	2" Knife Blade
11	Drill	Off	0.0	0.0 (0%)	Inches	Manual	Utility Blade Knife
12	Drill	Off	0.0	0.0 (0%)	Inches	Manual	Creasing Wheel

Esc	Hide Unmanaged F1	Sort Recent F2	Sort Tool# F3	Sort Remaining F4	Save F10
-----	----------------------	-------------------	------------------	----------------------	-------------

Tool Life Management Screen Buttons:

- **Hide Unmanaged (F1):** Click to hide all tools that have Total Life set to "0" or "Off".
- **Sort Recent (F2):** Click to sort the list by recent.
- **Sort Tool # (F3):** Click to sort the list by tool number.
- **Sort Remaining (F4):** Click to sort the list by % life remaining.
- **Save (F10):** Click to save any changes made on the current screen.

6.2.2 Load

The load button is used to load a GCode program into CNC12. Compatible GCode files traditionally use either the .cnc or .nc file extensions.

Load Button (F2):

Setup F1	Load F2	MDI F3	Run F4	CAM F5	Edit F6	Utility F7	Graph F8	Digitiz F9	Shut Down F10
-------------	------------	-----------	-----------	-----------	------------	---------------	-------------	---------------	------------------

6.2.3 MDI

The MDI button allows for the operator to manually send individual GCode lines to the controller.

MDI Button (F3):

Setup F1	Load F2	MDI F3	Run F4	CAM F5	Edit F6	Utility F7	Graph F8	Digitiz F9	Shut Down F10
-------------	------------	-----------	-----------	-----------	------------	---------------	-------------	---------------	------------------

MDI Screen:



Press the enter/return key on the keyboard or click on the cycle start button in the lower-right corner of the panel to execute the input line of GCode. Executed lines move up one space for easy review. Pressing the up-arrow key on the keyboard scrolls through previously entered GCode to be easily executed again. The Paste Position (F2) button can be used to paste the current machine's X/Y/Z (or other configured axes) work position into the text input window. The Rapid On/Off (F9) button can be used to turn the rapid overrides on or off.

6.2.4 Run

The Run button allows for the operator to manually adjust certain runtime conditions or restart a program from a specific line or tool callout.

Run Button (F4):

Setup F1	Load F2	MDI F3	Run F4	CAM F5	Edit F6	Utility F7	Graph F8	Digitiz F9	Shut Down F10
-------------	------------	-----------	-----------	-----------	------------	---------------	-------------	---------------	---------------------

Run Screen:

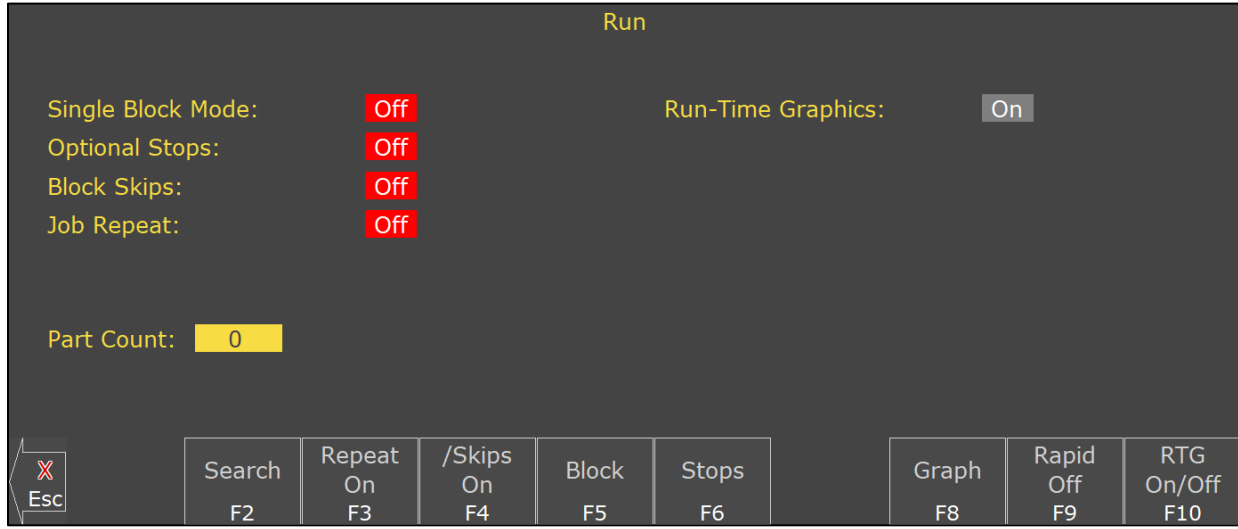

Run Screen Buttons:

- Search (F2): Opens search screen to search loaded GCode file for restart position.
- Repeat On/Off (F3): Toggles Job Repeat on or off.
- /Skips On/Off (F4): Toggles Block Skips on or off.
- Block (F5): Toggle Single Block Mode on or off.
- Stops (F6): Toggle Optional Stops on or off.
- Graph (F8): Runs a graph of the loaded file with the selected runtime conditions.
- Rapid On/Off (F9): Toggles Rapid Overrides on or off.
- RTG On/Off (F10): Toggles Real Time Graphics on or off.

Search (Restart) Screen:

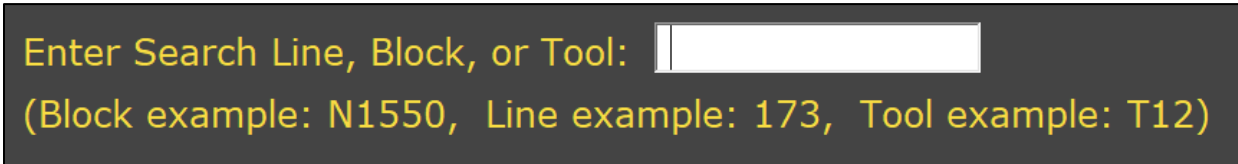

Clicking the Search (F2) button will open this screen, allowing the operator to input the line that they wish to restart the program on. This line can be inputted as the actual line number, the N line number, or a tool number callout. Pressing Cycle Start or the Accept Button (F10) will start the program from the specified search line.

6.2.5 CAM

The CAM Intercom functionality is disabled by default on all CAMaster Centroid CNC systems. To enable CAM Intercom functionality, please contact CAMaster Technical Support.

Use of the CNC system with the CAM Intercom functionality is not supported by CAMaster Technical Support. If the CAM button is pressed while the functionality is disabled (CAM Selection will be displayed on the screen), press the ESC key on the keyboard to return to the main screen of CNC12.

CAM Button (F5):

Setup F1	Load F2	MDI F3	Run F4	CAM F5	Edit F6	Utility F7	Graph F8	Digitiz F9	Shut Down F10
-------------	------------	-----------	-----------	-----------	------------	---------------	-------------	---------------	---------------------

6.2.6 Edit

The Edit button allows for the operator to manually alter the currently loaded GCode file in the default system file editor.

Edit Button (F6):

Setup F1	Load F2	MDI F3	Run F4	CAM F5	Edit F6	Utility F7	Graph F8	Digitiz F9	Shut Down F10
-------------	------------	-----------	-----------	-----------	------------	---------------	-------------	---------------	---------------------

6.2.7 Utility

The Utility button allows for the operator to view system logs or create a report for technical support reasons.

Utility Button (F7):

Setup F1	Load F2	MDI F3	Run F4	CAM F5	Edit F6	Utility F7	Graph F8	Digitiz F9	Shut Down F10
-------------	------------	-----------	-----------	-----------	------------	---------------	-------------	---------------	---------------------

Utility Screen:

Esc	Restore Report F2	Color Picker F5	User Maint F6	Create Report F7	Import License F8	Logs F9	Acorn Wizard F10
-----	-------------------------	-----------------------	---------------------	------------------------	-------------------------	------------	------------------------

Utility Screen Buttons:

- **Restore Report (F2):** Opens a system file open dialog to restore a previous report.
- **Color Picker (F5):** Opens the CNC12 Color Picker allowing color customization for CNC12.
- **User Maint (F6):** Displays buttons for File Operations, Centroid Manual, Machine Notes, Backup Files, and Restore Files.
- **Create Report (F7):** Opens a system file save dialog to save the current CNC system report.

- **Import License (F8):** Opens a system file open dialog to import a CNC12 license file.
- **Logs (F9):** Displays buttons for Error Logs, Statistical Information, Export Logs, MPU12 Stats, and HSC Errors.
- **Acorn Wizard (F10):** Opens the Acorn Wizard (Acorn Controller Only)

User Maint Screen:

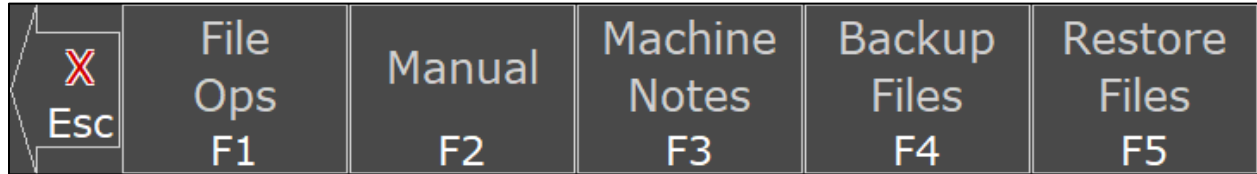

User Maint Buttons:

- **File Ops (F1):** Displays the File Options screen. This screen is not normally used on the CAMaster Centroid CNC system. Please refer to the Centroid Manual for more information about this screen.
- **Manual (F2):** Opens the Centroid Mill Manual PDF.
- **Machine Notes (F3):** Opens the machine_notes.txt file in the default system text editor.
- **Backup Files (F4):** Opens a system file save dialog to save a zip archive containing all GCode files saved under the C:\cncm\ncfiles directory.
- **Restore Files (F5):** Opens a system file open dialog to restore GCode files backed up via the Backup Files function.

6.2.8 Graph

The Graph Button opens up the Graph screen, allowing the operator to preview a GCode file.

Graph Button (F8):

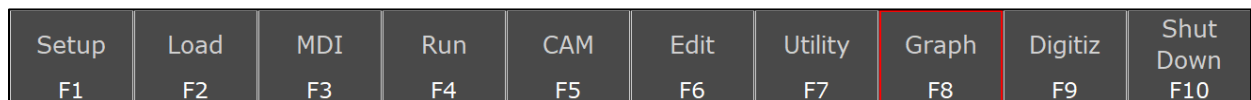

Graph Screen:

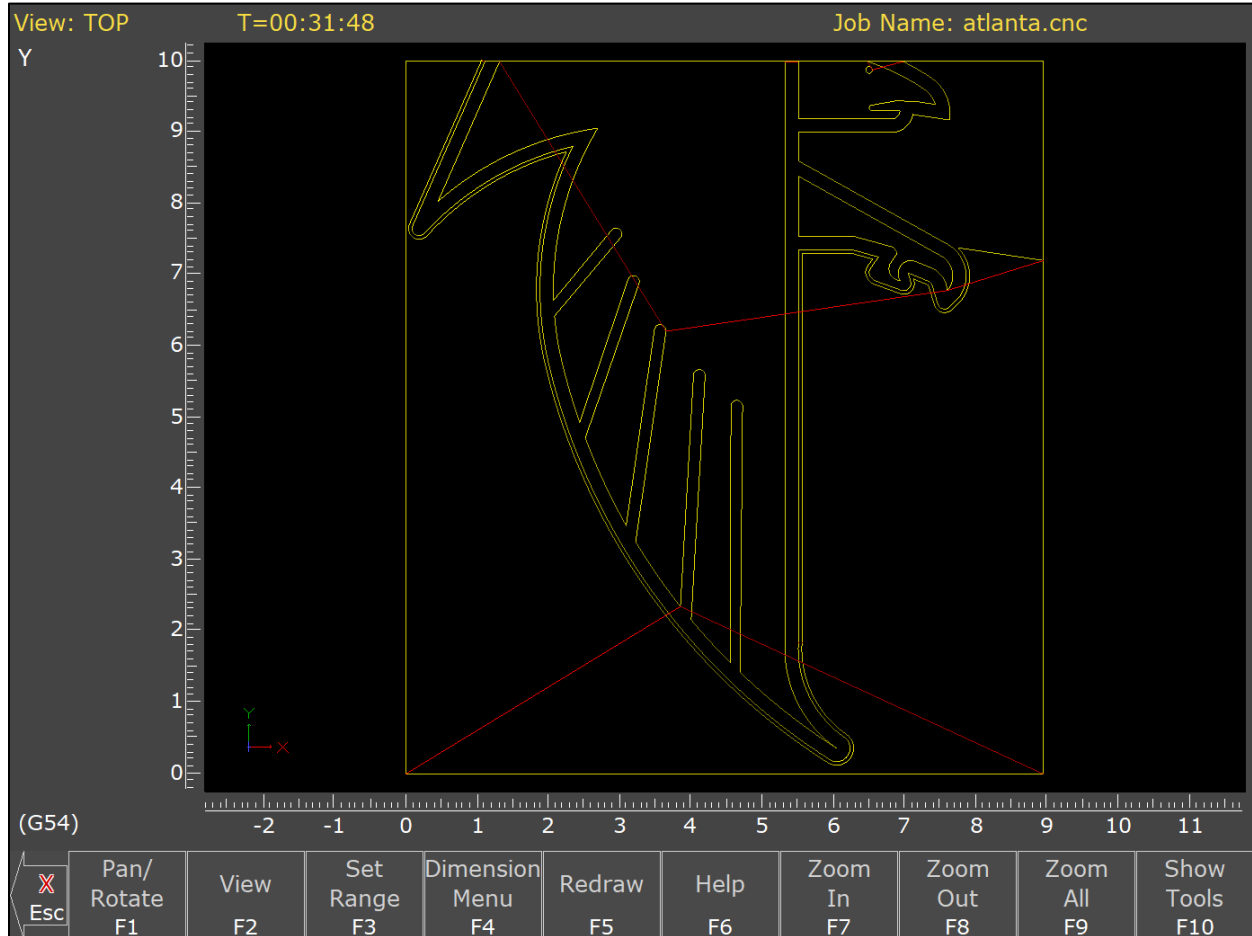

Graph Buttons:

- **Pan/Rotate (F1):** Toggles between pan and rotate mode on the graphic display screen.
- **View (F2):** Toggles between a few preset display viewpoints.
- **Set Range (F3):** Allows the operator to set a graphing range between specified start and end GCode lines.
- **Dimension Menu (F4):** Displays buttons to view single GCode lines or measure between two points on the Graph screen.
- **Redraw (F5):** Redraws the preview on the Graph screen.
- **Help (F6):** Displays a help message containing general information and hotkeys for the Graph screen.
- **Zoom In (F7):** Zooms in on the current preview. (Scroll Up)
- **Zoom Out (F8):** Zooms out of the current preview. (Scroll Down)
- **Zoom All (F9):** Zooms In/Out to fit the entire preview in the Graph screen.
- **Show Tools (F10):** Opens the tool window allowing the operator to show or hide specific tools or rapid movements.

6.2.9 Digitiz

The digitize button is used to open the Digitiz screen.

Digitiz Button (F9):

Setup F1	Load F2	MDI F3	Run F4	CAM F5	Edit F6	Utility F7	Graph F8	Digitiz F9	Shut Down F10
-------------	------------	-----------	-----------	-----------	------------	---------------	-------------	---------------	---------------------

This screen's function is to use a digitizing probe to set part zeros and coordinate system rotations. This is not a standard feature included with the CAMaster Centroid CNC system. For more information, please refer to the Centroid Manual.

6.2.10 Shut Down

The Shut Down button is used to display the Shut Down screen to allow the operator to park the machine and exit CNC12.

Shut Down Button (F10):

Setup F1	Load F2	MDI F3	Run F4	CAM F5	Edit F6	Utility F7	Graph F8	Digitiz F9	Shut Down F10
-------------	------------	-----------	-----------	-----------	------------	---------------	-------------	---------------	---------------------

Shut Down Screen:

Esc X	Park F1	Power Off F2		System Prompt F6		Exit CNC12 F9
----------	------------	--------------------	--	------------------------	--	---------------------

Shut Down Buttons:

- **Park (F1):** Commands the machine to move to the park position (after pressing Cycle Start).
- **Power Off (F2):** Shuts down the computer. **WARNING:** This will cause an immediate system shut down and you may lose any unsaved work!
- **System Prompt (F6):** Opens the Windows Command Prompt.
- **Exit CNC12 (F9):** Closes the CNC12 Program.

6.3 Virtual Control Panel

The Virtual Control Panel (VCP) is located on the right-hand side of the screen when CNC12 is first started. This panel contains all of the operator buttons used to control the CNC system, including jog buttons, speed selection, tool selection, work origin setting, and other miscellaneous functions.

Example VCP Screen (SignPro):

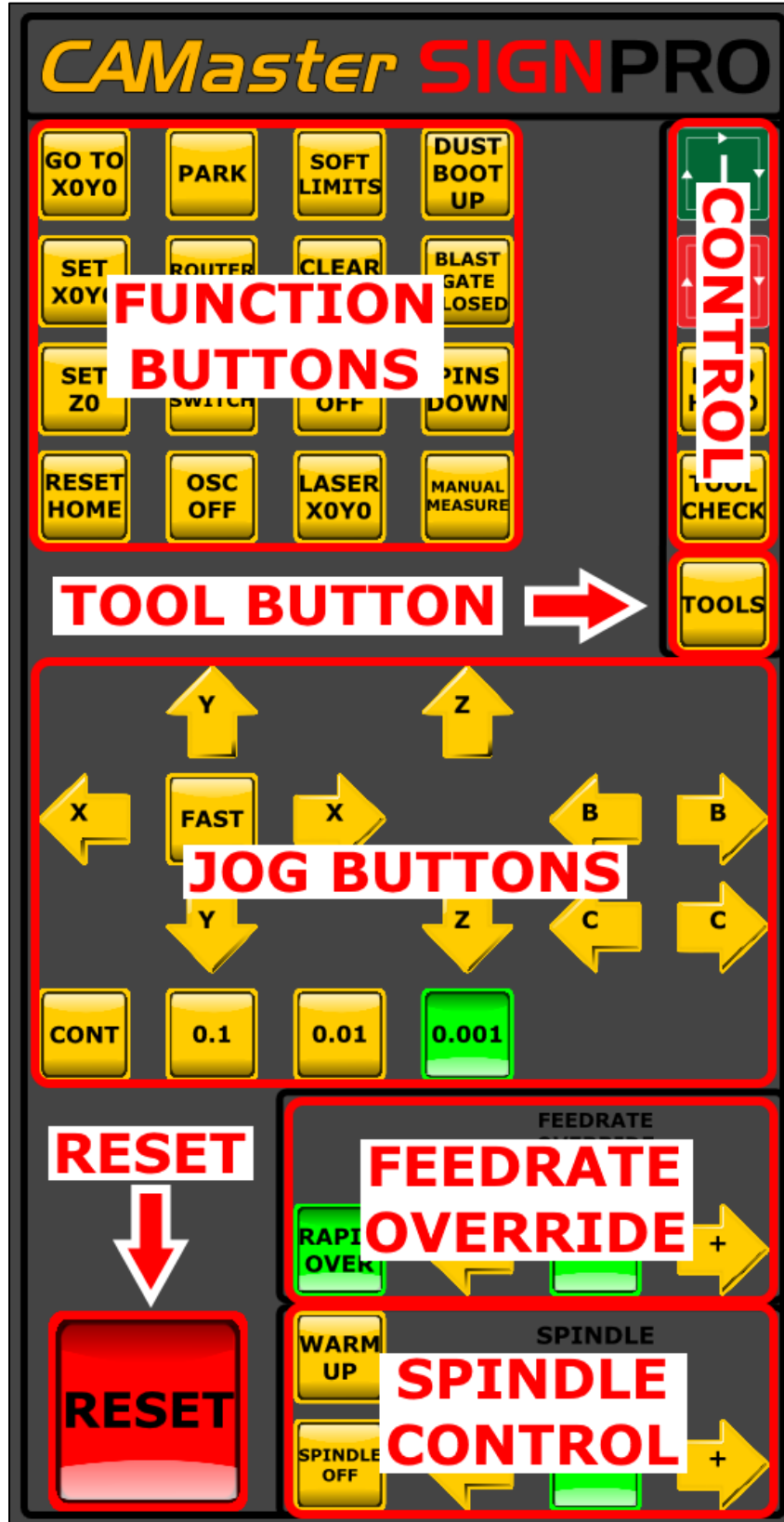

VCP Labels:

- **Control Buttons:** Includes buttons to start/stop the CNC system as well as toggle the tools screen.
- **Function Buttons:** Includes buttons to set the workpiece origin and many other miscellaneous functions.
- **Jog Buttons:** Includes buttons to jog the individual machine axes at continuous speeds or incremental distances.
- **Feedrate Override Buttons:** Includes buttons to override the current feedrate on the CNC system.
- **Spindle Control Buttons:** Includes buttons to override the current spindle speed, warm up the spindle, and turn the spindle off.
- **Reset Button:** Click to enter or exit reset mode on the CNC system.
- **Tool Button:** Click to toggle between displaying the function and tool buttons.

6.3.1 Control Buttons

The control buttons are used to control the main functions of the CNC system.

Control Buttons:



Control Buttons: (From Top to Bottom)

- **Cycle Start:** Click to begin (or resume) the currently loaded program or MDI line.
- **Cycle Cancel:** Click to stop the currently running program or action.
- **Feed Hold:** Click to pause the currently running program or action.
- **Tool Check:** Click to pause the currently running program and lift the Z axis to the home position to inspect the tool.
- **Tools:** Click to toggle between displaying the function and tool buttons.

6.3.2 Function Buttons

The function buttons perform various functions to control certain aspects of the CNC system. Below is a list of each button and the function(s) they correspond to.

Blast Gate Open/Closed Button:

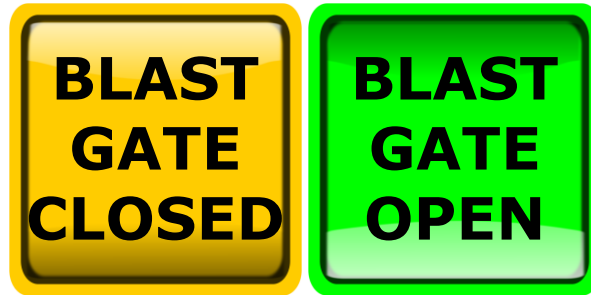

The Blast Gate Open/Closed button is used to toggle the blast gate open and closed. When the blast gate is open, the vacuum line is diverted from the tabletop allowing material to be moved without active vacuum suction holding it in place. Closing the blast gate will allow the vacuum suction to return. This button is only present on blast gate equipped CNC systems.

Cal Switch Button:



The Cal Switch button is used to reset the Z zero of the spoilboard after resurfacing. Clicking this button will prompt the user to jog the CNC system until the loaded tool touches the top of the spoilboard, then commands the CNC system to raise the Z head to the home position and jog over the tool measure switch. The CNC system will then lower the Z head until it touches off the tool on the tool measure switch to register the new Z zero location. No tools need to be remeasured after this process.

Clear Zeros Button:



The Clear Zeros button is used to remove any local G92 X and Y offset currently applied. This returns the current work coordinate system to match the absolute machine position for all axes, except for Z. The Z local offset will be set to match the currently configured spoilboard height as long as a G43 (tool height compensation) is applied, configured via the calibrate switch function. Any head offsets (from auxiliary heads such as knives, laser engravers, camera, etc.) are taken into consideration with this function and will remain until unloaded.

Dust Boot Up/Down Button:

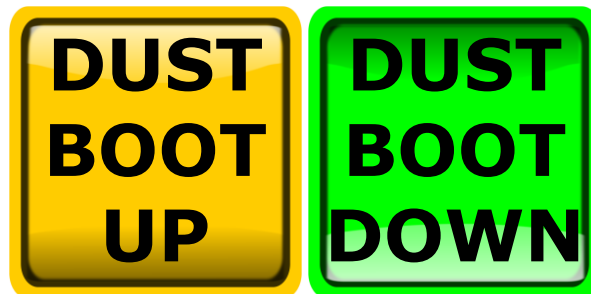

The Dust Boot Up/Down button is used to actuate the dust boot up and down. This button is the same as commanding a “M94/28” to lower the dust boot down or commanding a “M95/28” to raise the dust boot up. This button is only present on ATC spindle equipped CNC systems.

Go To X0Y0 Button:



The Go To X0Y0 button is used to command the CNC system to raise the head to the Z home position and make a rapid movement to the current X and Y zero of the active work coordinate system.

Laser Air On/Off Button:



The Laser Air On/Off button is used to turn the laser engraver air assist on and off. This button is only present on laser engraver equipped CNC systems of 14W power and higher. Stinger models and some Panther models with this feature do not have a button, but instead have a manual ball valve to turn the air assist on and off above the laser engraver unit.

Laser On/Off Button:



The Laser On/Off button is used to turn the laser crosshair on and off. This button is only present on crosshair laser equipped CNC systems.

Laser X0Y0 Button:



The Laser X0Y0 button is used to set the current X0Y0 location to the position of the laser crosshair. This button will only work when the laser crosshair is active. This button is only present on crosshair laser equipped CNC systems.

Lathe Home Button:



The Lathe Home button is used to command the CNC system to raise the head to the home position and move to the configured lathe home X position. This button is only present on recoil lathe equipped CNC systems.

Manual Measure Button:



The Manual Measure button is used to set the G43 tool height offset for the currently loaded tool. Example: If tool number 3 is loaded when this button is pressed, the current z height offset (H3) will update in order for the current position to register as Z zero. This button

is to be used with the knife tools, the laser engraver, the camera, and large diameter spindle tools that are too large to be used with the tool measure switch.

Mister On/Off Button:



The Mister button is used to command the mister to turn on or off. This button is the same as commanding a “M07” to turn the mister on or commanding a “M09” to turn the mister off. This button is only present on mister equipped CNC systems.

MPG Button:



The MPG button is used to indicate when the Manual Pulse Generator (Wireless Handheld Pendant) is currently controlling the CNC system. When the MPG is on and connected to the CNC system and starts controlling the system, this button will turn to the green online state to show a visual indicator that an external device is currently controlling the CNC system. When the MPG is turned off and/or disconnected, the button will return to the yellow offline state to indicate that external control of the CNC system is offline. Clicking this button has no effect and exists purely as an indicator.

Osc. On/Off Button:



The Osc. On/Off button is used to turn the oscillation of the oscillating tangential knife on and off. This button is the same as commanding a “M39” to turn the oscillating on or commanding a “M40” to turn the oscillating off. This button is only present on oscillating tangential knife equipped CNC systems.

Park Button:



The Park button is used to command the CNC system to move to the park position and unload the active tool if the CNC system is ATC compatible. The park position is used to move the CNC system to a location close to where the homing switches are located in order to expedite the homing process upon the next system startup. The Park function will also prompt the operator if they would like to clear all local zero offsets or not (yes or no).

Pins Up/Down Button:



The Pins Up/Down button is used to command the pop-up pins to pop up or retract down. The pop-up pins are used for easy loading or large sheet materials to line up with the machine X and Y zero position. Note: When the spindle is commanded to turn on (M3), the pop-up pins will retract to the down position for safety. This button is only present on pop-up pins equipped CNC systems.

Reset Home Button:



The Reset Home button is used to command the CNC system to perform the homing initialization process to reset the CNC system's absolute zero positions. On CNC systems with absolute encoders (Panther and SignPro models), this will not reset the absolute zero positions but instead perform any other applicable initialization processes that normally occur on system startup.

Router Home Button:



The Router Home button is used to command the CNC system to move to the machine absolute X0 Y0 Z0 position. The router home function prompts the operator to hit Cycle Start before unloading the active tool (if ATC compatible) and clearing any local zero offsets.

Set X0Y0 Button:



The Set X0Y0 button is used to set a local G92 offset for the X and Y axes. This button is the same as commanding a "G92 X0Y0". This offset is only applied for the currently active work coordinate system.

Set Z0 Button:



The Set Z0 button is used to set a local G92 offset for the Z axis. This button is the same as commanding a "G92 Z0". This offset is only applied for the currently active work coordinate system.

Soft Limits On/Off Button:



The Soft Limits button is used to toggle the soft limits of the CNC system on and off. When the soft limits are on, motion is restricted to remain within the working boundary of the machine limits to prevent crashes (except for the Z negative direction). When the soft limits are off, the machine can be moved infinitely in all directions. **WARNING:** Jogging with the soft limits off is dangerous and should only be used to recover from error states. Jogging into the machine hard stops is considered a crash and should be avoided at all costs!

Touch Top Button:



The Touch Top button is used to use the current spindle tool to probe the physical touch top surface plate in order to set a local Z zero offset. This button is only present on touch top equipped CNC systems.

Zero Lathe Button:



The Zero Lathe button is used to reset the absolute zero position of the recoil lathe to the current position. This button is the same as commanding a “M26/A”. This button is only present on recoil lathe equipped CNC systems.

6.3.3 Jog Buttons

The following buttons below can be used by the operator to jog the machine in the desired direction. The machine will not jog outside the defined soft limits unless they are currently turned off. When an axis is outside the soft limits while the soft limits are on, that axis will only jog towards the direction to return inside the soft limits. It is possible to have additional jog buttons not displayed below for other axes that are included on your CNC system.

Jog Buttons: (X, Y, Z Axes Shown)

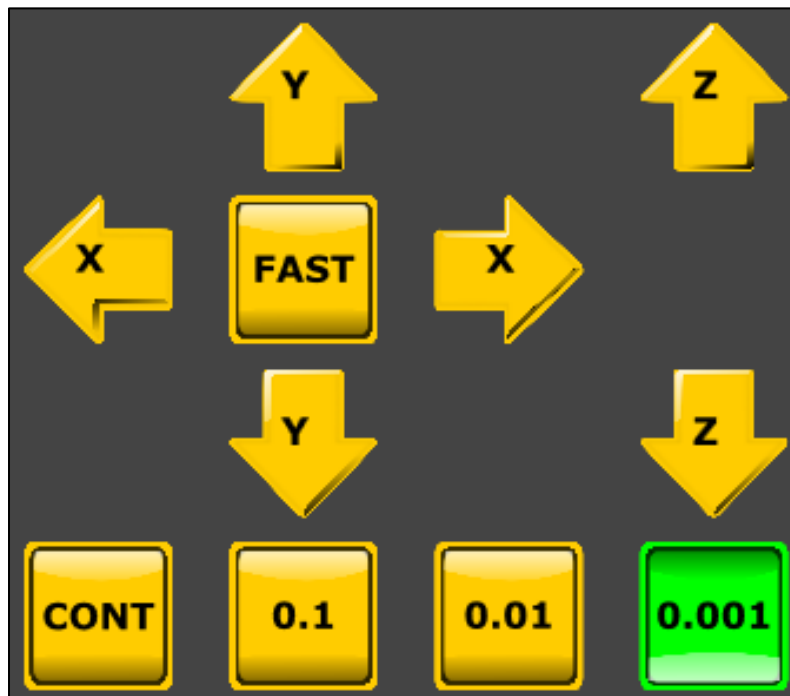

There are two jog behaviors that are possible: jogging by set increment or continuous jogging. The current jog speed selection is displayed on the button inside the X and Y jog buttons and toggles between slow and fast when clicked. The button on the lower left-hand corner displays the currently active mode (continuous or incremental) and toggles between the two jog modes when clicked. The selected jog increment will be highlighted in green. The continuous jog mode behaves in a way in which the axis will move until the jog button is either released or it hits a soft limit. The incremental jog mode behaves in a way in which the axis will be commanded to move the specified distance each time a jog button is pressed. The commanded units are in inches.

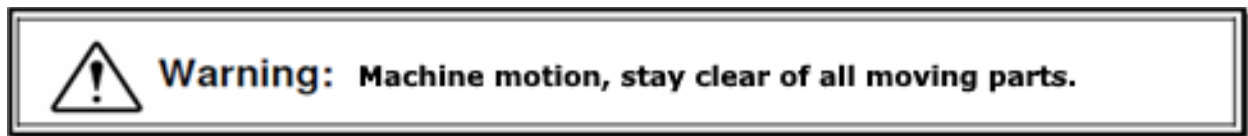

6.3.4 Feedrate Override Buttons

The feedrate override buttons are used to control the current feedrate override of the CNC system. The plus arrow or minus arrow buttons are used to increase or decrease the current feedrate override percentage. When the feedrate override is not currently overridden, the 100% button will be highlighted in green. To return to no feedrate override, click the 100% button. The rapid over button is used to toggle between including the rapid movements or not with the feedrate override. Please note that rapid speeds will not increase above 100%.

Feedrate Override Buttons:

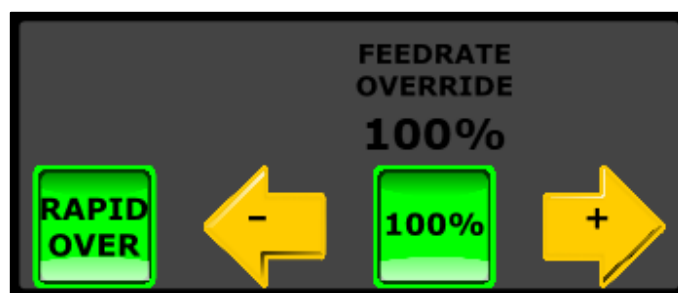

6.3.5 Spindle Control Buttons

The spindle control buttons are used to control various functions related to the spindle. The plus arrow or minus arrow buttons are used to increase or decrease the current spindle speed. When the spindle speed is not currently overridden, the 100% button will be highlighted in green. To return to the currently set spindle speed, click the 100% button. The warm up button will automatically load a tool if no tool is currently loaded (on ATC spindle equipped CNC

systems) and start the spindle warm up process. The spindle off button can be clicked to turn the spindle off when currently running.

Spindle Control Buttons:

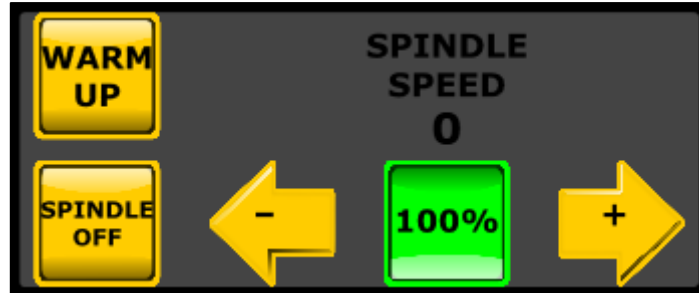

6.3.6 Reset Button

The reset button is used to reset the controller after an error state occurs. Clicking this button once will set the CNC system into a reset mode (along with the message “9033 Reset Initiated, Press Reset to Clear” in the message window). Clicking this button again will clear the reset mode and return the CNC system to a ready state.

Reset Button:



6.3.7 Tool Buttons

The tool buttons are used to command tool changes for the ATC spindle, knife, laser, and camera equipped CNC systems. These features are only currently available on Panther and SignPro models. Below is a list of each button and the function(s) they correspond to.

T# Button:



The T# buttons are used to command a tool change to load the selected spindle tool number. These buttons are the same as commanding a “T# M6” where the “#” is the number of the requested tool to load. This button is only present on ATC spindle equipped CNC systems.

T# Knife Button:



The T# Knife buttons are used to command a tool change to load the selected knife tool number. These buttons are the same as commanding a “T# M6” where the “#” is the number of the requested tool to load. This button is only present on ATC knife equipped CNC systems.

Osc. Knife Mode Button:



The Osc. Knife Mode button is used to command a tool change to load the oscillating tangential knife module. This button is the same as commanding a “T# M6”, where the “#” matches the tool number of your oscillating tangential knife. This button is only present on oscillating knife equipped CNC systems.

Knife Mode Button:



The Knife Mode button is used to command a tool change to load the quick-change tangential knife module. This button is the same as commanding a “T# M6”, where the “#” matches the tool number of your tangential knife. This button is only present on quick-change tangential knife equipped CNC systems.

Laser Engraver Mode Button:



The Laser Engraver Mode button is used to command a tool change to load the laser engraver module. This button is the same as commanding a “T# M6”, where the “#” matches the tool number of your laser engraver. This button is only present on laser engraver equipped CNC systems.

CutVision Button:



The CutVision button is used to open up the CutVision external application for camera registration. Please refer to the CutVision manual for more information about how to operate the CutVision software. This button is only present on camera equipped CNC systems.

Route Mode Button:



The Route Mode button is used to command a tool change to unload the currently active tool. This button is the same as commanding a "T0 M6". This button is only present CNC systems equipped with at least one of the above tool screen buttons.

6.3.8 Hotkeys

There are many hotkeys that can be used to control the CNC system from the operator keyboard. Please refer to the table below for all available hotkeys.

Hotkey:	Button(s):
Increase Jog Increment	Delete
Decrease Jog Increment	Insert
Change Jog Mode (Continuous / Incremental)	Ctrl I
Jog X Positive	Right Arrow
Jog X Negative	Left Arrow
Jog Y Positive	Up Arrow
Jog Y Negative	Down Arrow
Jog Z Positive	Page Up
Jog Z Negative	Page Down
Jog A Positive	Home
Jog A Negative	End
Cycle Start	Enter OR Alt S
Cycle Cancel	Escape
Feed Hold	Space
Tool Check	Ctrl T
Single Block Mode	Ctrl B
Feedrate Override +	Ctrl +
Feedrate Override -	Ctrl -
Feedrate Override 100%	Ctrl \
Spindle Speed +	Ctrl >
Spindle Speed -	Ctrl <
Spindle Speed 100%	Ctrl ?
Spindle Stop	Ctrl Q

NOTE: Not all hotkeys above may be functional on all CNC systems given the equipped features.

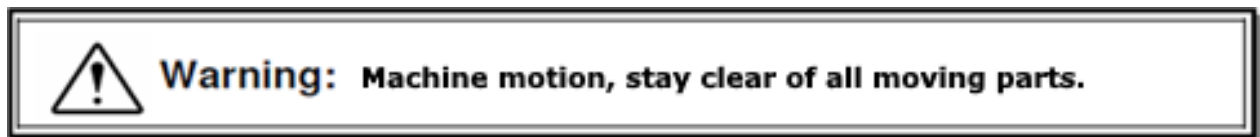

7 Machine Operation

The following sections describe the correct operating procedure for the CNC system. If at any time there is a question about the safe operation for any feature of the CNC system, contact CAMaster Technical Support for guidance. Additionally, training can be provided by CAMaster at the request of the customer to cover the standard operation of the CNC system and more. For more information about training, please refer to the training section of this manual.

7.1 Tool Installation

The following steps should be followed to perform a tool change on a CAMaster Centroid CNC system. These directions are written for a tool installation on an ATC tool cone but also loosely apply to a manual spindle.

1. Insert the tool collet of the appropriate size into the collet nut. The top of both should be flush.



2. Insert the correct tool cone for your spindle into the tool cone tightening fixture and begin loosely threading the collet nut assembly.
3. Insert the tool into the tool collet to the manufacturer's recommended offset distance.
4. Use the collet wrench to tighten the collet nut to the spindle manufacturer's recommended torque of 100 ft/lbs.
5. For ATC tool fork installation, please refer to the picture below for correct tool installation location and orientation.





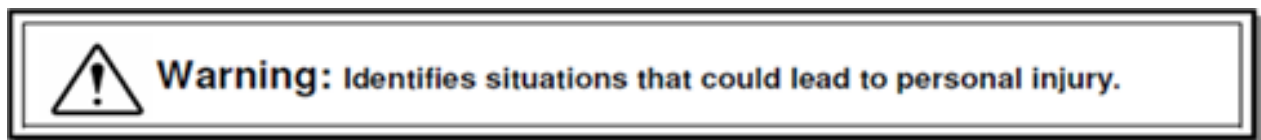

The green button present on ATC spindles can be used to manually open the tool clamp. Make sure to grasp the tool before pressing this button as any tool currently installed will fall out if not supported. Ensure that you avoid touching any sharp edges of the tooling while installing or removing the tool cone from the spindle.



7.2 Start-Up Procedure

The following steps should be followed to perform the correct start-up procedure on the CAMaster Centroid CNC system.



1. Turn the switch on the front right-hand side of the CNC system clockwise all the way until it reaches the “ON” position.
2. Turn the PC on and wait for it to boot up and log into the Windows desktop.
3. The CNC12 should automatically start. If it does not, wait 30 seconds and start it manually by clicking the CNC12 Icon on the Taskbar.  or 
4. If there is a 9033 alarm active on system startup, it can be cleared with the Reset button. 
5. If you have CNC system that requires homing, press the Cycle Start button to home the machine. 
6. Install a tool cone into the spindle (either manually or via machine tool change).
7. Press the Warm Up button. 
8. The CNC system is ready to begin normal operation.



Warning: Machine motion, stay clear of all moving parts.

7.3 Spoil Board Preparation

The following steps should be followed to prepare the spoil board for use on your CNC system. Please have the spoil board surfacing program ready before continuing.

1. Install the surfacing tool into the spindle (manually or via machine tool change).
2. Click the Clear Zeros button to clear any local offsets. 
3. Turn the vacuum hold down on (if applicable).
4. Jog the head down in the Z Axis until the surfacing bit is just barely touching the top surface of the spoilboard.
5. Click the Set Z0 button. 
6. Click the Load button (F2) on CNC12 and load in the spoil board surfacing program. CAMaster does not provide spoil board surfacing programs.
7. Preview the file with the Graph button (F8) to ensure that everything looks correct before continuing.
8. Click the Cycle Start button to begin the program. 
9. Once the surfacing program is complete, refer to the Switch Calibration section of this manual to recalibrate the tool measure switch.



Warning: Machine motion, stay clear of all moving parts.



The spoil board itself should be either MDF (Medium-Density Fiberboard), LDF (Light-Density Fiberboard), or ULDF (Ultra-Light-Density Fiberboard) material. The purpose of the spoil board is to act as a sacrificial layer in-between the material to be cut and the top of the CNC system. Note that a lighter density material will allow for more vacuum flow to pass through but also compresses more when the vacuum hold down is engaged. MDF is the preferred material choice for most applications. It is recommended to start with a spoil board or 1" of thickness and replacing after it is reduced to less than $\frac{3}{4}$ " of thickness. When surfacing the spoil board, both sides should be surfaced to ensure that any vacuum flow is maintained while also accounting for the flatness of the CNC system top. If vacuum flow is leaking from the sides, they can be sealed with tape, wax, or glue.

7.4 Standard Operating Procedure

The following steps should be followed to ensure the correct and safe operation of the Centroid CNC system.

7.4.1 Switch Calibration

The following steps should be followed to calibrate the tool measure switch on a Centroid CNC system.



1. Load/install a tool (typically a ¼" to ½" flat bottom endmill) into the spindle (either manually or via machine tool change).
2. Turn the vacuum hold down on (if applicable).
3. Lower the Z Axis until the tool just barely touches the top of the spoil board.
4. Click the Tools button to bring up the tool buttons. 
5. Click the Cal Switch button to begin the Calibrate Switch process. 
6. Follow the prompts on the screen to complete the process.



Warning: Machine motion, stay clear of all moving parts.

7.4.2 Manual Tool Measuring

The following steps should be followed to perform a manual tool measure on the Centroid CNC system. This process should be used for tooling that is too large or too delicate for use with the tool measure switch.



1. Manually install the tool into the spindle using the directions from the Tool Installation section of this manual.
2. Insert the tool into the tool collet to the manufacturer's recommended distance and begin tightening the nut with the collet wrench.
3. Ensure that the collet nut is tightened to 100 ft/lbs.
4. Lower the tool in the spindle so that it just barely touches the top of the spoil board.
5. Click the Tools button to bring up the tool buttons. 
6. Click the Manual Measure button. 



Warning: Identifies situations that could lead to personal injury.

7.4.3 ATC Tool Change

The following steps should be followed to perform an ATC tool change on an ATC compatible Centroid CNC system.

1. Click the Tools button to bring up the Tool buttons. 
2. Click the button for the tool you wish to load into the spindle.  ,  , etc.
3. The CNC system will automatically unload the current tool or active head if currently loaded.
4. The CNC system will then move to the configured station for the selected tool and pick it up.
5. After loading the selected tool, the machine will move back into the defined soft limits.



Warning: Machine motion, stay clear of all moving parts.

7.4.4 FTC Mode Operation

The following steps should be followed to use FTC Mode (Fast Tool Change Mode) on a Centroid CNC system. This feature is for CNC systems with a manual non-ATC spindle. Please refer to the header that represents the method of where your Z zero will be set and how you are setting the local Z zero.

Table Surface Without Touch Top:

1. Install the first tool the GCode file will use.
2. Measure the tool:
 - a. Automatically
 - i. Jog the Z head as high as it can go.
 - ii. Navigate to Setup (F1) > Tool (F2) > Offset Lib (F1).
 - iii. Highlight the Hight Offset value for row H001.
 - iv. Select Auto Measure (F3).
 - v. Hit Cycle Start to begin the auto measure process.
 - vi. Select Save (F10).
 - b. Manually









- i. Lower the head until the bit barely touches the material surface.
 - ii. Select the Manual Measure button on the VCP. 
3. Jog head to location on the table that you want to set the local X0Y0.
4. Click the “Set X0Y0” button on the VCP. 
5. Lower the head until the bit barely touches the spoil board.
6. Click the “Set Z0” button on the VCP. 

Table Surface with Touch Top:



1. Install the first tool the GCode file will use.
2. Measure the tool:
 - a. Automatically
 - i. Jog the Z head as high as it can go.
 - ii. Navigate to Setup (F1) > Tool (F2) > Offset Lib (F1).
 - iii. Highlight the Hight Offset value for row H001.
 - iv. Select Auto Measure (F3).
 - v. Hit Cycle Start to begin the auto measure process.
 - vi. Select Save (F10).
 - b. Manually
 - i. Lower the head until the bit barely touches the material surface.
 - ii. Select the Manual Measure button on the VCP. 
3. Jog head to location on the table that you want to set the local X0Y0.
4. Click the “Set X0Y0” button on the VCP. 
5. Connect the Touch Top device (if not already plugged in).
6. Place the Touch Top on the spoil board below the head so that the loaded tool is directly above the correct touch off location.
7. Click the “Touch Top” button on the VCP. 

Material Surface without Touch Top:

1. Install the first tool the GCode file will use.
2. Measure the tool:
 - a. Automatically

- i. Jog the Z head as high as it can go.
 - ii. Navigate to Setup (F1) > Tool (F2) > Offset Lib (F1).
 - iii. Highlight the Hight Offset value for row H001.
 - iv. Select Auto Measure (F3).
 - v. Hit Cycle Start to begin the auto measure process.
 - vi. Select Save (F10).
 - b. Manually
 - i. Lower the head until the bit barely touches the material surface.
 - ii. Select the Manual Measure button on the VCP. 
7. Jog head to location on the table that you want to set the local X0Y0.
8. Click the “Set X0Y0” button on the VCP. 
9. Lower the head until the bit barely touches the material surface.
10. Click the “Set Z0” button on the VCP. 

Material Surface with Touch Top:

1. Install the first tool the GCode file will use.
2. Measure the tool:
 - a. Automatically
 - i. Jog the Z head as high as it can go.
 - ii. Navigate to Setup (F1) > Tool (F2) > Offset Lib (F1).
 - iii. Highlight the Hight Offset value for row H001.
 - iv. Select Auto Measure (F3).
 - v. Hit Cycle Start to begin the auto measure process.
 - vi. Select Save (F10).
 - b. Manually
 - i. Lower the head until the bit barely touches the material surface.
 - ii. Select the Manual Measure button on the VCP. 
3. Jog head to location on the table that you want to set the local X0Y0.
4. Click the “Set X0Y0” button on the VCP. 
5. Connect the Touch Top device (if not already plugged in).
6. Place the Touch Top on the spoil board below the head so that the loaded tool is directly above the correct touch off location.

7. Click the “Touch Top” button on the VCP.



Programs with Tool Changes During a GCode File:

1. When the GCode file calls out a “T# M6” command while executing a program, the CNC system will stop, raise the Z head, and move the head to the front of the table.
2. A message will appear prompting the operator to change the tool in the spindle to the requested tool.
3. After the operator changes the tool and tells the CNC system to continue, the CNC system will move over to the tool measure switch and measure the tool in the spindle.
4. Follow the prompts for the removal/installation of the dust boot when applicable.
5. From there, the program will continue from where it left off.



Warning: Machine motion, stay clear of all moving parts.

7.4.5 Single Tool Operation

The following steps should be followed for all single tool operations on a Centroid CNC system. This feature is for CNC systems with a manual non-ATC spindle or for an ATC spindle equipped spindle without a registered tool in the spindle. Please refer to the header that represents the method of where your Z zero will be set and how you are setting the local Z zero. These steps are to be followed in the exact order they are presented, otherwise the Z height may be deeper than expected.

Z Zero Set on Table Surface without Touch Top:

1. Install tool or tool cone into the spindle.
2. Jog head to location on the table that you want to set the local X0Y0.
3. Click the “Set X0Y0” button on the VCP.
4. Lower the head until the bit barely touches the spoil board.





5. Click the “Set Z0” button on the VCP.



Z Zero Set on Table Surface with Touch Top:

1. Install tool or tool cone into the spindle.
2. Jog head to location on the table that you want to set the local X0Y0.

3. Click the “Set X0Y0” button on the VCP. 
4. Connect the Touch Top device (if not already plugged in).
5. Place the Touch Top on the spoil board below the head so that the loaded tool is directly above the correct touch off location.

6. Click the “Touch Top” button on the VCP. 

Z Zero Set on Material Surface without Touch Top:

1. Install tool or tool cone into the spindle.
2. Jog head to location on the table that you want to set the local X0Y0.

3. Click the “Set X0Y0” button on the VCP. 
4. Lower the head until the bit barely touches the material surface.

5. Click the “Set Z0” button on the VCP. 

Z Zero Set on Material Surface with Touch Top:

1. Install tool or tool cone into the spindle.
2. Jog head to location on the table that you want to set the local X0Y0.

3. Click the “Set X0Y0” button on the VCP. 
4. Connect the Touch Top device (if not already plugged in).
5. Place the Touch Top on material surface below the head so that the loaded tool is directly above the correct touch off location.

6. Click the “Touch Top” button on the VCP. 



Warning: Machine motion, stay clear of all moving parts.

7.4.6 Oscillating Knife Mode

The following steps should be followed to enter Oscillating Knife Mode on a Centroid CNC system.

1. Click the Tools button to bring up the Tool buttons. 

2. Click the Knife Mode button to change the current active head to the oscillating knife.



3. By default, the oscillation motor turns on when Knife Mode is activated. To toggle the

oscillation motor on or off, click the Osc On/Off button.



4. To exit Oscillating Knife Mode, click the Route Mode button or load any other tool.





Warning: Machine motion, stay clear of all moving parts.

7.4.7 Tangential Knife Mode

The following steps should be followed to enter Tangential Knife Mode on a Centroid CNC system.

1. Click the Tools button to bring up the Tool buttons. 

- a. Non-ATC Knife: Click the Knife Mode button to change the current active head to the tangential knife. 

- b. ATC Knife: Click the desired tool button to unload the currently active head and load the requested ATC knife tool.  , etc.

2. To exit Tangential Knife Mode, click the Route Mode button or load any other tool (if the CNC system is ATC compatible). 





Warning: Machine motion, stay clear of all moving parts.





7.4.8 Laser Engraver Mode

The following steps should be followed to enter Laser Engraver Mode on a Centroid CNC system. Please note that the Laser Air On/Off button is only present on Panther or SignPro models. Stingers equipped with a 14W or 24W laser engraver have a manual control valve above the laser engraver unit to control the air assist.

Laser Engraver Mode on Stinger:

1. Click the Laser Engraver Mode button to change the current active head to the laser engraver. 
2. For CNC systems equipped with a 14W or 24W laser engraver, the air assist can be toggled on or off with the manual control valve above the laser engraver unit.
3. To exit Laser Engraver Mode, click the Route Mode button or load any other tool (if the CNC system is ATC compatible). 

Laser Engraver Mode on Panther and SignPro:



1. Click the Tools button to bring up the Tool buttons. 
2. Click the Laser Engraver Mode button to change the current active head to the laser engraver. 
3. For CNC systems equipped with a 14W or 24W laser engraver, some models can toggle the air assist on or off with the Laser Air On/Off button.   Otherwise, the air assist can be toggled on or off with the manual control valve above the laser engraver unit.
4. To exit Laser Engraver Mode, click the Route Mode button or load any other tool (if the CNC system is ATC compatible). 



Warning: Machine motion, stay clear of all moving parts.

7.4.9 Camera Mode

The following steps should be followed to enter Camera Mode on a Centroid CNC system.

1. Click the Tools button to bring up the Tool buttons. 
2. Click the CutVision button to open the external CutVision application. 
3. Inside the CutVision application, click the Camera Mode button to change the current active head to the camera.

4. For specific operating instructions on the CutVision application, please refer to the CutVision User Manual.
5. To exit Camera Mode, return to the CNC12 application and click the Route Mode button

or load any other tool (if the CNC system is ATC compatible).



NOTE: For more information regarding the CutVision camera registration system, please refer to the CutVision manual.



Warning: Machine motion, stay clear of all moving parts.

7.4.10 Crosshair Laser Operation

The following steps should be followed to set a local XY zero offset with the crosshair laser on a Centroid CNC system.

1. Click the Laser On/Off button to turn the crosshair laser on or off.
2. Jog the machine so that the crosshair is lined up with the desired XY location for the new local zero offset.
3. Click the Laser X0Y0 button.
6. The CNC system will then move the spindle over the location of the crosshair laser and set that position as the current XY local zero offset.



Warning: Machine motion, stay clear of all moving parts.

7.5 Smoothing Setup

Smoothing can be used to reduce the amount of runtime of a program by smoothing the path that the CNC system takes. Sharp corners are rounded over and the CNC system will not come to an exact stop on each line of commanded motion. To open the Smoothing screen in CNC12, go to Setup (F1) > Smoothing Setup (F8). Multiple smoothing presets exist to get you started, but your specific application may require tweaking to get the output that you are looking for. Each preset has slider bars that control a few basic smoothing parameters but are not a comprehensive list of smoothing parameters available to customize. For more information about further configuring all available smoothing parameters, please refer to the Centroid Manual.

Smoothing Presets:



- **Exact Stop (F1):** Default operating mode. Machine will come to an exact stop for every commanded line of motion.
- **Precision Mill (F2):** Included Centroid preset.
- **Contouring Mill (F3):** Included Centroid preset.
- **Precision Router (F4):** Included Centroid preset.
- **Contouring Router (F5):** Included Centroid preset.
- **CAMaster Factory (F6):** CAMaster customized preset optimized for most smoothing applications on your CNC system.

CAMaster Factory Smoothing Preset:

- **NBpts (P221):** 5.0
- **STEP (P222):** 0.003
- **Umax (P223):** 800.0
- **Centripetal (P224):** 0.0
- **W (P226):** 20.0
- **Minimum Angle (P227):** 45.0
- **S Curve (P228):** 0.0
- **Curve Feedrate Multiplier (P230):** 1.2
- **Acceleration Multiplier (P231):** 1.0

7.6 Shutdown Procedure

The following steps should be followed to perform the correct shutdown procedure on the Centroid CNC system.

1. Click the Park button. This will unload the currently active tool (if the CNC system is equipped with an ATC), prompt the operator to clear any local zero offsets or not, and move the machine to the X0 Y0 Z0 absolute position. 
2. Click the Shut Down button (F10) on CNC12 application. Then, click the Exit CNC12 button (F9).
3. Turn the switch on the front right-hand side of the CNC system counterclockwise until it reaches the “OFF” position.
4. Once CNC12 has fully closed, click the Windows icon in the lower left-hand corner of the screen. 
5. Click the Power Icon and select the Shut Down option.



Warning: Machine motion, stay clear of all moving parts.

7.7 Maintenance

It is the responsibility of the customer to perform all maintenance duties and ensure the correct functionality of any present automatic maintenance features of the CNC system.

7.7.1 Maintenance Schedule

Please refer to the maintenance schedule below for a basic guideline on when to perform regular maintenance on the CNC system. Additional maintenance may be required outside of this recommended schedule depending on usage and environment variables.

Daily:

- Blow off the CNC system at the end of each day.
- Make sure the CNC system is dust free around the ball screw and all bearings.
- Clean and inspect the tool collet each time an endmill / bit is changed or replaced.

Weekly:

- Perform all daily maintenance.
- * Clean all the rails and the ball screw and properly lubricate them.
- With the CNC system powered off completely, lightly blow out the interior of the control box.
- Remove the filter cover and blow off the control box air filters.
- Inspect and blow off the spindle fan while removing any particulates.

Bi-Weekly:

- Perform all daily and weekly maintenance.
- Check the tensioning blot on the X and both the Y gearboxes. (Call CAMaster Technical Support if these seem loose)
- Check all visible wires for looseness and any wear.
- * Clean and grease ball screw and ball nut.
- * Clean and grease linear rail bearing blocks. (Not necessary for Autolube equipped CNC systems)

* In high dust areas or in cases of heavy use, increase frequency of cleaning and lubrication.



Warning: Identifies situations that could lead to personal injury.

7.7.2 Manual Lubrication

For all bearings on the CNC system, please use a *NLG12 Multi-Purpose Red Lithium Grease*.

Linear Bearing & Ball Screw Nut Lubrication:

To lubricate the linear bearing blocks or the ball screw nut manually, a goose neck nylon grease gun adapter can be used to reach the grease zerk fitting. The nylon grease adapter does not lock onto the zerk fitting and will need a constant pressure applied to it for the grease to enter the bearing.

If there is more than a small amount of grease coming out of the grease zerk, there is most likely not enough pressure applied to the grease gun during application. If there is grease coming out of the bearing itself, that is normal and confirms that the grease is reaching the expected location. The technician should be able to feel the grease going into the bearing if all is going well.

After lubricating each bearing, the attached axis needs to be moved at least 5 inches one direction and back to ensure that the bearing balls have cycled fully. This can be done via jogging the CNC system under power once all personnel are clear of all moving parts.

There are multiple lubrication points on each CNC system. Please refer to the following list of lubrication points for each axis.

Lubrication Points: (Stinger 1)

- **X Axis:** The X axis has two bearings on each rail that can be accessed on the side of the head.
- **Y Axis:** The Y axis has two bearings on each rail that can be accessed on the underside of both sides of the frame.
- **Z Axis:** The Z axis has one bearing on each rail that can be accessed on either side of the head. The ball screw is located behind the main Z plate of the head and need to be greased directly on the screw and worked in manually.
- **Total:** 10 Bearing Lubrication Points and 1 Ball Screw

Lubrication Points: (Stinger 2/3)

- **X Axis:** The X axis has two bearing on each rail that can be accessed on the side of the head.
- **Y Axis:** The Y axis has two bearings on each rail that can be accessed on either side of the frame.
- **Z Axis:** The Z axis has two bearings on each rail that can be accessed on either side of the head. The ball screw bearing block is located behind the main Z plate of the head and can be accessed either between the two Z bearings on one side of the head or from below when the head is in the lowered position.
- **Total:** 12 Bearing Lubrication Points and 1 Ball Screw Lubrication Point

Lubrication Points: (Panther)

- **X Axis:** The X axis has four remote lubrication points that can be accessed on the rear sides of the head (2x per side).
- **Y Axis:** The Y axis has two bearings on each rail that can be accessed on either side of the frame.
- **Z Axis:** The Z axis has four remote lubrication points that can be accessed on the top of the head above the spindle. The ball screw also has a remote lubrication point next to the Z bearing lubrication points.
- **Total:** 13 Remote Lubrication Points

7.7.3 Automatic Lubrication

For CNC systems equipped with an automatic lubrication system, please refill the tank with a *NLGI2 Multi-Purpose Red Lithium Grease*. The grease zerk fitting used to refill the tank can be found on the bottom of the automatic lubrication unit that is usually located on the left side of the X head.

The automatic lubrication system automatically greases the linear bearing blocks and ball screw nut after a predetermined amount of machine motion occurs. To manually perform an additional cycle of lubrication, press the Manual Lube button on the VCP screen.



7.7.4 Control Box

The control box houses most of the electrical components for the CNC system and must be maintained to ensure proper working conditions for many of the internal components. The air filter on the intake port of the main control box must be removed and blown out with compressed air from time to time. Additionally, the box itself must be gently blown out with compressed air to remove any dirt or debris that got into the box. Visually inspect any fans to ensure that they are clean and in good working condition.

NOTE: When inside the control box for any reason, first ensure that the CNC system (including the control PC) is fully powered off (both at the monitor stand if present and the service disconnect or circuit breaker).



7.7.5 Dust & Debris Removal

It is important that all dust and debris be removed from the CNC system after any significant buildup. Special attention should be given to the linear rails and gear rack to ensure that they are clean of dust and debris before operation. To remove dirt and debris from the CNC system, it is recommended to blow off the affected areas with a compressed air gun. If there are any areas where dirt or debris has coagulated with any machine lubricants or coolant, gentle wiping by hand may be required.

8 Post-Processor Support

All Centroid equipped CNC systems are compatible with many different post processors to meet a variety of machine setups. Many CAMaster CNC systems currently manufactured come with Vectric or Fusion 360 licensing that operators can utilize for toolpathing. If there is a different CAM platform that you wish to use with the CAMaster Centroid platform, please see the Other Posts section below for more information about how setup a compatible post processor.

8.1 Supported Posts

Officially supported post processors for the following platforms can be found in the sections below.

- Vectric – VCarve Pro
- Vectric – Aspire
- Autodesk – Fusion 360
- Autodesk – HSMWorks (via Solidworks)

8.1.1 Vectric Posts

Vectric programs such as VCarve Pro and Aspire are CAM software packages made for CNC routing. The table below lists most of the post-processors available for the CAMaster Centroid platform. To request any of these post processors, please contact CAMaster Technical Support.

Post Processor Name	Feature Compatibility	Unit
CAMaster Centroid INCH	Single Tool, ATC, FTC, CutVision, Laser Engraver	inches
CAMaster Centroid MM	Single Tool, ATC, FTC, CutVision, Laser Engraver	mm
CAMaster Centroid Recoil XtoA INCH	Single Tool, ATC, FTC, Recoil	inches
CAMaster Centroid Recoil XtoA MM	Single Tool, ATC, FTC, Recoil	mm

NOTE: This is not an exhaustive list of available post processors. Please contact CAMaster Technical Support if the post processor you require is not listed here.

8.1.2 Fusion 360 Posts

Fusion 360 is a CAD program that also contains CAM capabilities. The latest Fusion 360 post can be obtained by emailing CAMaster Technical Support at support@camaster.com.

8.1.3 HSMWorks Posts

HSMWorks is a Solidworks add-on that allows for CAM integration in a style similar to Fusion 360 CAM. Any of the Fusion 360 post processors mentioned in the section above can be used with HSMWorks.

8.2 Other Posts

The CAMaster Centroid platform is engineered to be an open architectural hardware and software platform that can work with any CAD/CAM package available. When making a new post processor, please use the following diagram for correct machine axis orientation. The Z Axis zero origin is located at the fully raised head position. All rotational axes follow the right-hand rule for positive rotational direction determination. Linear axis travel is determined by machine model. Rotation axis travel is from -360° to 360° but can be commanded past those limits. Tangential axes are the same as rotary axes but are commanded in revolutions (1 revolution = 360°).



9 Supported GCode

The following sections provide a comprehensive list of all the supported G and M codes on the CAMaster Centroid controller.

9.1 G Codes

GCode:	Description:	Comment(s):
G00	Rapid Positioning	G0 moves move at the rapid feed rate.
G01	Linear Interpolation	G1 moves reference the F register for feed rate.
G02	CW Circular / Helical Interpolation	G2 moves reference the F register for feed rate. Provide the R register for radius mode or I/J/K registers for circle center mode.
G03	CCW Circular / Helical Interpolation	G3 moves reference the F register for feed rate. Provide the R register for radius mode or the I/J/K registers for circle center mode.
G04	Dwell	Provide the dwell time as seconds with the P register. Minimum Time = 0.01 Maximum Time = 327.67s
G09	Exact Stop	Commands motion to decelerate to a stop. Equivalent to a "G4 P0.01"
G10	Parameter Setting	Allows the setting of parameters for various program operations. Example: "G10 P73 R.05" to set the peck drilling retract amount to 0.05.
G17	Circular Interpolation Plane Selection XY	Use to select the XY plane for circular interpolation commands (G02 & G03). G17 is the default plane.
G18	Circular Interpolation Plane Selection ZX	Use to select the ZX plane for circular interpolation commands (G02 & G03).
G19	Circular Interpolation Plane Selection YZ	Use to select the YZ plane for circular interpolation commands (G02 & G03).
G20	Programming in Inches	Selects inches as the active unit for the currently running file.
G21	Programming in Millimeters	Selects millimeters as the active unit for the currently running file.
G28	Return to Reference Point	Commands the machine to return to the currently configured reference point (normally machine zero).
G29	Return from Reference Point	Commands the machine to return to the previous position commanded before the last G28 or G30 command within the current job.

G30	Return to Secondary Reference Point	Commands the machine to return to the currently configured secondary reference point (normally machine zero).
G40	Cutter Compensation Cancel	Cancel cutter compensation if currently active.
G41	Cutter Compensation Left	Offsets the cutter tool one half of the tool diameter from the currently selected D register to the left of the workpiece relative to the direction of travel. Example: "G41 D3" to enable left cutter compensation using the tool diameter from the 3 rd D register from the offset library.
G42	Cutter Compensation Right	Offsets the cutter tool one half of the tool diameter from the currently selected D register to the right of the workpiece relative to the direction of travel. Example: "G42 D3" to enable right cutter compensation using the tool diameter from the 3 rd D register from the offset library.
G43	Tool Length Compensation Positive	Applies a tool length compensation to a selected tool in the positive direction (work from part surface up). Example: "G43 H1" to enable tool length compensation using the value from the 1 st H register from the offset library.
G44	Tool Length Compensation Negative	Applies a tool length compensation to a selected tool in the negative direction (work from Z zero down). Example: "G44 H1" to enable tool length compensation using the value from the 1 st H register from the offset library. The negative compensation direction is not commonly used.
G49	Tool Length Compensation Cancel	Removes any actively applied tool length compensation. This is the same as a "G43 H0" command.
G50	Scaling / Mirroring Off	Turns scaling / mirroring off.
G51	Scaling / Mirroring On	Applies a scaling relative to a defined X/Y/Z coordinate with scaling factors defined with the I/J/K registers. Example: "G51 X0 Y0 Z0 I1 J2 K1" to scale the current program with respect to the X/Y/Z zero by 2 along the Y axis. The default scale factor is 1:1 for each axis. To mirror an axis, use a negative value in the scaling factor for that axis. Example: "G51 X0 Y0 Z0 I-1 J1 K1" to mirror the current program along the X axis. If the scaling is the same for all axes, the P parameter can be used instead of I/J/K.
G52	Offset Local Coordinate System Origin	Use to shift the local coordinate system origin by a specified distance. This command is not modal (and not cumulative), but will shift the local zeros on all work coordinate systems.
G53	Machine Coordinate System	With reference to absolute machine zero. G53 positioning uses the rapid positioning feedrate.

G54	Work Coordinate System 1	Select work coordinate system #1.
G55	Work Coordinate System 2	Select work coordinate system #2.
G56	Work Coordinate System 3	Select work coordinate system #3.
G57	Work Coordinate System 4	Select work coordinate system #4.
G58	Work Coordinate System 5	Select work coordinate system #5.
G59	Work Coordinate System 6	Select work coordinate system #6.
G61	Exact Stop Mode	Turns on exact stop mode. Can be turned off with a G64.
G64	Cutting Mode	Turns on continuous cutting mode. Can be turned off with a G61.
G65	Call Macro	Call a macro file. Example: G65 "program.cnc". Please refer to the Centroid Manual for more information.
G73	High Speed Peck Drilling Cycle	<p>In this cycle, the drill makes a rapid move to the retract position above the piece (R), then moves into the piece an increment (Q) at the specified feed rate (F) until the final drill position is reached (Z).</p> <p>Supported Parameters: G73 Xn Yn Zn Rn Qn Pn Fn Kn where:</p> <p>X = X position to drill. Y = Y position to drill. Z = Final drill depth position. R = Retract Position – the initial position above the material, safe for moving among multiple holes. Q = Peck Depth – the amount to be added to the drilling depth each peck cycle. P = Dwell in seconds at the bottom hole location. F = Feed rate for drilling (still retained after a G80 is commanded). K = Number of cycles to repeat, default is 1.</p>
G80	Cancel Modal Command	Designates the end of a modal cycle operation such as G73/G83.
G81	Drilling and Spot Drilling Cycle	<p>In this cycle, the drill makes a rapid move to the retract position above the piece (R), then moves into the piece at the specified feed rate (F) until the final drill position is reached (Z).</p> <p>Supported Parameters: G81 Xn Yn Zn Rn Fn Kn where:</p>

		<p>X = X position to drill. Y = Y position to drill. Z = Final drill depth position. R = Retract Position – the initial position above the material, safe for moving among multiple holes. F = Feed rate for drilling (still retained after a G80 is commanded). K = Number of cycles to repeat, default is 1.</p>
G82	Drilling Cycle with Dwell	<p>In this cycle, the drill makes a rapid move to the retract position above the piece (R), then moves into the piece at the specified feed rate (F) until the final drill position is reached (Z), then pauses for delay (P).</p> <p>Supported Parameters: G81 Xn Yn Zn Rn Pn Fn Kn where:</p> <p>X = X position to drill. Y = Y position to drill. Z = Final drill depth position. R = Retract Position – the initial position above the material, safe for moving among multiple holes. P = Dwell in seconds at the bottom hole location. F = Feed rate for drilling (still retained after a G80 is commanded). K = Number of cycles to repeat, default is 1.</p>
G83	Deep Hole Drilling Cycle	<p>In this cycle, the drill makes a rapid move to the retract position above the piece (R), then moves into the piece an increment (Q) at the specified feed rate (F) until the final drill position is reached (Z). At the end of each increment, the drill will rapidly return to the retract position, then proceed with the next peck. This macro remains enabled until a G80 is executed.</p> <p>Supported Parameters: G83 Xn Yn Zn Rn Qn Pn Fn Kn where:</p> <p>X = X position to drill. Y = Y position to drill. Z = Final drill depth position. R = Retract Position – the initial position above the material, safe for moving among multiple holes. Q = Peck Depth – the amount to be added to the drilling depth each peck cycle. P = Dwell in seconds at the bottom hole location. F = Feed rate for drilling (still retained after a G80 is</p>

		commanded). K = Number of cycles to repeat, default is 1. K = Number of cycles to repeat, default is 1.
G85	Boring Cycle	In this cycle, the operation is the same as a G81 cycle but with the tool retracted with a feedrate move instead of a rapid move.
G89	Boring Cycle with Dwell	In this cycle, the operation is the same as a G85 cycle but with an optional dwell at the bottom of the hole specified with the P parameter as dwell time in seconds.
G90	Absolute Positioning Mode	Commands all move commands to be made in absolute mode until a G91 is commanded.
G91	Incremental Positioning Mode	Commands all move commands to be made in incremental mode until a G90 is commanded.
G92	Set Local Offset Position	Sets local offset positions on currently specified WCS. When used with an axis letter, sets that current axis position to the specified local offset position.
G98	Initial Point Return	Use to set the Z positive return level to the top point for canned cycles. This is the default behavior.
G99	R Point Return	Use to set the Z positive return level to the specified R value for canned cycles.
G117	Rotation of Plane Selection XY	In this command, the operation is the same as a G17 but includes two additional optional parameters: P = Arc plane angle of rotation in degrees around the first (X) axis. Q = Arc plane angle of rotation in degrees around the second (Y) axis.
G118	Rotation of Plane Selection ZX	In this command, the operation is the same as a G18 but includes two additional optional parameters: P = Arc plane angle of rotation in degrees around the first (Z) axis. Q = Arc plane angle of rotation in degrees around the second (X) axis.
G119	Rotation of Plane Selection YZ	In this command, the operation is the same as a G19 but includes two additional optional parameters: P = Arc plane angle of rotation in degrees around the first (Y) axis. Q = Arc plane angle of rotation in degrees around the second (Z) axis.

9.2 M Codes

MCode:	Description:	Comment(s):
M00	Stop for Operator	Stops machine motion and prompts operator to hit Cycle Start to continue.
M01	Optional Stop for Operator	If optional stops are turned on, stops machine motion and prompts operator to hit Cycle Start to continue.
M02	Restart Program	Commands the Z axis to the home position, performs any requested movement, and restarts the program from the first line.
M03	Spindle On (Clockwise)	Turns the spindle on in the clockwise direction. Note: A spindle speed must be requested on or before this line for the spindle to actually spin up.
M04	Spindle On (Counterclockwise)	Turns the spindle on in the counterclockwise direction. Note: A spindle speed must be requested on or before this line for the spindle to actually spin up. This is an optional feature and may not be present on all CNC systems.
M05	Spindle Off	Stops the spindle.
M06	Tool Change	Commands the CNC system to perform a tool change to the currently specified T register. Example: "T3 M6" to command the machine to perform a tool change to pick up tool number 3.
M07	Mister On	Turns the mister coolant on.
M08	Flood Coolant On	Not currently supported by the CAMaster CNC system.
M09	Mister Off	Turns the mister coolant off.
M15	Spindle Clamp Open	Opens the ATC tool clamp for ATC equipped CNC systems and turns the purge air on. Cannot be used when the spindle is on (M3/M4). This has the same functionality as pressing the manual unclamp button on the side of the ATC spindle. WARNING: This will drop any actively loaded tool from the spindle.
M16	Spindle Clamp Close	Closes the ATC tool clamp and turns the purge air off.
M25	Move to Z Home	Commands the system to rapid to the Z zero position in machine coordinates. This is the same as the "G0 Z0" command.
M26	Set Axis Home	Sets the machine home position (zero position) for the specified axis to the current position. WARNING: This may break you CNC system if used improperly. Do not use without a thorough understanding of how this will affect the CNC system. Please contact CAMaster Technical Support if the machine position needs to be reset.
M30	End Program	Specifies the end of a program.

M34	User Customizable Macro	Macro is empty from factory. Customize for your own needs.
M37	Laser Engraver Enable	Enables the laser engraving cutting mode.
M38	Laser Engraver Disable	Disables the laser engraving cutting mode.
M39	Tangential Knife Oscillate On	Turns the oscillating motor of the tangential knife on.
M40	Tangential Knife Oscillate Off	Turns the oscillating motor of the tangential knife off.
M44	Touch Top	Performs a touch top move to set a local Z zero offset off of the material surface.
M45	Set Z0	Sets the current Z position as the local Z zero offset.
M46	Set X0Y0	Sets the current Z position as the local X Y zero offset.
M47	Calibrate Switch	Sets the current position as the calibrated top of spoilboard Clear Zeros return height.
M48	Soft Limit Toggle	Toggles the soft limits on or off.
M51	Clear Zeros	Removes the X Y local zero offset and sets the local Z zero offset to the calibrated top of spoilboard height from the configured Calibrate Switch position.
M52	Check X0Y0 with Crosshair Laser	Turns the crosshair laser on and moves it over the current local X0Y0 location.
M53	User Customizable Macro	Macro is empty from factory. Customize for your own needs.
M54	User Customizable Macro	Macro is empty from factory. Customize for your own needs.
M55	Router Home	Prompts the user to hit Cycle Start before removing the active tool (if ATC compatible), clear any local zero offsets, and park the CNC system at the X0Y0 location. Edit the file in the directory of "C:\cncm\mfunc55.mac" to change the configured X and Y position to suit your needs.
M56	Go to X0Y0	Commands the CNC system to move to the current X0Y0 position.
M57	User Customizable Macro	Macro is empty from factory. Customize for your own needs.
M58	User Customizable Macro	Macro is empty from factory. Customize for your own needs.
M59	Reset Home	Commands the CNC system to reinitialize the motors and re-home each axis.
M60	Park	Commands the CNC system to move to the current Park position (X0Y0 by default). Edit the file in the directory of "C:\cncm\system\park.mac" to change the configured X and Y position to suit your needs.

M77	Spindle Warm Up	Commands the CNC system to load a tool if no tool is currently loaded (on ATC compatible systems) and start the spindle warm up process. This process takes approximately 5 minutes.
M91	Move to Minus Home	Commands the specified axis to move towards the minus home switch until it triggers, then moves away until the switch releases.
M92	Move to Plus Home	Commands the specified axis to move towards the plus home switch until it triggers, then moves away until the switch releases.
M93	Release Motor Power	Releases motor power for the axis specified, otherwise release all axes.
M94	Turn Output On	Overrides the current output state for the specified output number turning that output on.
M95	Turn Output Off	Overrides the current output state for the specified output number turning that output off.
M98	Call Subprogram	Call a macro file. Example: M98 "program.cnc". The subprogram must contain a M99 command on the last line to tell the controller to return to the main file. Up to 20 nested levels of subprograms may be called at once. Please refer to the Centroid Manual for more information.
M99	Return from Subprogram	Returns from a subprogram back into the original program (or subprogram the active subprogram was called from). This must be the last line of the subprogram. Any lines below this will be ignored. If there is no M99 specified, a M99 is assumed to be at the end of the file.
M100	Wait for Input to Open	Commands the system to wait until the specified input opens. Example: "M100/1" to wait until input 1 opens.
M101	Wait for Input to Close	Commands the system to wait until the specified input closes. Example: "M100/1" to wait until input 1 closes.
M103	Programmed Action Timer	Not currently supported by the CAMaster CNC system.
M104	Cancel Programmed Action Timer	Not currently supported by the CAMaster CNC system.
M105	Move Minus to Switch	Moves the specified axis in the minus direction until the specified switch opens. Example: "M105/X P5 F30" to move the X axis in the negative direction until input # 5 opens at a feedrate of 30 units per minute.
M106	Move Plus to Switch	Moves the specified axis in the plus direction until the specified switch opens. Example: "M106/X P5 F30" to move the X axis in the positive direction until input # 5 opens at a feedrate of 30 units per minute.
M107	Output BCD Tool	Not currently supported by the CAMaster CNC system.

	Number	
M108	Enable Override Controls	Re-enables the feedrate and/or spindle speed override if previously disabled with an M109. A parameter of 1 indicates the feedrate override and a parameter of 2 indicates the spindle speed override. Example: "M108/1/2" to re-enable the feedrate override and the spindle speed override.
M109	Disable Override Controls	Disables the feedrate and/or spindle speed override within a program. A parameter of 1 indicates the feedrate override and a parameter of 2 indicates the spindle speed override. Example: "M109/1/2" to disable the feedrate override and the spindle speed override.
M200	Stop for Operator Formatted String	Pauses the currently running job and prompts the operator for action. Example: M200 "Please insert the tool into the spindle and press Cycle Start to continue."
M201	Stop for Operator Formatted String (Stealth)	This command functions the same as an M200 but does act as if there is not program running while the pause is happening. Not normally used over an M201 without a reason.
M224	Prompt for Operator Input Formatted String	Displays a formatted string and then accepts a user input. Example: M224 #300 "Please enter the desired feed rate:" Where #300 is the user var number the user input is written to.
M225	Display Formatted String for a Period of Time	Displays a formatted string for a specified period of time in seconds. Example: #100 = 0 M225 #100 "Please enter the desired feed rate:" Where #100 is the temporary user variable that defines the length of time (a time of zero will last indefinitely).
M1000 to M1015	Change Graphing Color	Changes the default graphing color on the CNC12 Graph screen. This only applies to feed rate moves, not rapid moves. The purpose of this is to highlight different areas of the program of the graphing screen. The default color is yellow. M1000 = Black (Note: The default background color is black) M1001 = Navy Blue M1002 = Green M1003 = Teal M1004 = Orange

		M1005 = Blue M1006 = Lime M1007 = Aqua M1008 = Maroon M1009 = Purple M1010 = Olive M1011 = Gray M1012 = Red (The same as rapid moves) M1013 = Fuchsia M1014 = Yellow (Default) M1015 = White
--	--	--

9.3 Other Registers

Register:	Description:	Comment(s):
A	A Axis Position (Rotational Axis Around X Axis)	Rotational axis used for Recoil Lathe positioning.
B	B Axis Position (Rotational Axis Around Z Axis)	Rotational axis used for Oscillating Knife positioning.
C	C Axis Position (Rotational Axis Around Z Axis)	Rotational axis used for Tangential Knife positioning.
D	Tool Diameter Offset Number	Register selection for current tool diameter offset from the offset library.
E	Select Work Coordinate System	E1 through E6 selects the current active work coordinate system (E1 = G54, E2 = G55... E6 = G59).
F	Feed Rate	Feed rate specified in units per minute. (Inches or millimeters)
H	Tool Length Offset Number	Register selection for current tool length offset from the offset library.
I	Arc Center Along X Axis OR Scaling Factor	This is the relative X distance to the center of the circle from the beginning of the arc. For use with G02 and G03 circular interpolation moves. Scaling factor for use with G51 commands.
J	Arc Center Along Y Axis OR Scaling Factor	This is the relative Y distance to the center of the circle from the beginning of the arc. For use with G02 and G03 circular interpolation moves. Scaling factor for use with G51 commands.
K	Arc Center Along Z Axis OR Scaling Factor	This is the relative Z distance to the center of the circle from the beginning of the arc. For use with G02 and G03 circular interpolation moves. Scaling factor for use with G51 commands.

N	Block Number	If provided, this information is useful for troubleshooting locations inside GCode files or for the search function when preparing a program restart.
O	Program Number	Specifies a program number. If the program number is 9100-9999, the GCode from the O number through the next M99 will be extracted and placed in a separate subprogram/macro file. The lines will not be executed until the resulting file is called with an M98 or G65.
P	Dwell Time OR General Parameter.	This parameter has multiple functions based on the usage.
Q	Depth Parameter for Canned Drilling Cycles	This parameter sets the depth of cuts for canned drilling cycles.
R	Radius of an Arc OR Return Point OR General Parameter	This parameter has multiple functions based on the usage. The radius usage is for use with G02 and G03 circular interpolation moves.
S	Spindle RPM	Spindle RPM = From 0 to Max RPM.
T	Tool Selection	T# command will result in machine loading the commanded tool in the CNC12 software. The machine will not perform the requested tool change unless an M6 is also included: "T# M6"
X	X Axis Position	X Cartesian position of CNC system.
Y	Y Axis Position	Y Cartesian position of CNC system.
Z	Z Axis Position	Z Cartesian position of CNC system.
:	Start Visible Comment	Indicates the start of a comment. The GCode line will be ignored by the controller but displayed on the screen. This character must be the first character on the line.
;	Start Comment	Indicates the start of a comment. The remainder of the GCode line will be ignored by the controller.
#	User Variable	User variables that can be used to perform mathematical calculations or store data within programs. Variables in the range of 100-149 are temporary and are initialized to 0.0 at the start of each job. Variables in the range of 150-159 are user variables that will be retained in non-volatile memory. Variables in the range of 300-399 are user string variables and will exist until a CNC12 software restart. For the complete list of user variables, please refer to the Centroid Manual.

10 Troubleshooting

There are multiple reasons why an operator may be receiving an error. Please refer to the table below to assist with commonly found issues before reaching out to CAMaster Technical Support.

Problem:	Possible Solution(s):
CNC12 will not start/connect	<p>(1) Machine power is off. Turn the CNC system on via the switch on the front right-hand side of the machine (All the way clockwise).</p> <p>(2) Machine power is off. Verify that the control box door is closed and securely latched.</p> <p>(3) After turning the CNC system on, wait an additional 30 seconds before opening CNC12 to ensure that the PLC has fully started.</p> <p>(5) CNC12 shows “Initializing MPU” then shuts down. Power cycle the CNC system and PC.</p> <p>(4) Check the Windows Firewall and ensure that CNC12 is allowed access through the Firewall.</p> <p>(5) Ensure that the static IP address for the Ethernet adapter on the control PC has not changed from its default: 10.168.41.1</p> <p>(6) Ensure that the ethernet cable connected to the control PC is securely connected. Only use the provided shielded ethernet cable.</p> <p>(7) No communication with the controller. Contact CAMaster Technical Support for more assistance.</p>
E-Stop Active shown on CNC12 screen	<p>(1) Check all E-Stop switches and ensure that they are released (Rotate the button in a clockwise direction until the button springs free of the depressed position).</p> <p>(2) Machine power is off. Turn the CNC system on via the switch on the front right-hand side of the machine (All the way clockwise).</p> <p>(3) Machine power is off. Verify that the control box door is closed and securely latched.</p> <p>(4) No communication with the controller. Contact CAMaster Technical Support for more assistance.</p>
System will not enable	<p>(1) Ensure that all active alarms are cleared by clicking the reset button.</p> <p>(2) No communication with the controller. Contact CAMaster Technical Support for more assistance.</p>
Unsupported GCode	<p>(1) Use the Graph button (F8) on the CNC12 main screen to verify a GCode file before running it. Please fix any errors before continuing.</p>

	<p>(2) Ensure that you are using a CAMaster Centroid compatible Post Processor. Please refer to the Supported GCode and Post Processor section of this manual for more information.</p> <p>(3) Contact CAMaster Technical Support for more assistance.</p>
ATC spindle drops tool during a tool change	<p>(1) Ensure that the air connection to the CNC system is present and up to the minimum PSI requirements (≥ 100 PSI with a maximum of 110 PSI).</p> <p>(2) Check the dust boot for dirt or debris on the inside that may prevent the unit from travelling up to the fully raised position.</p> <p>(3) Verify that the tool fork is in a good working condition (straight, not bent, and not broken).</p> <p>(4) Verify the location of the tool fork is accurate by commanding the CNC system to load that tool from a tool unloaded state (T0).</p> <p>(5) Contact CAMaster Technical Support for more assistance.</p>
Loose movements on a single axis	<p>(1) On the X and Y axes, check the pinion gear and gear rack for missing or worn-down teeth. They may need replacing if damaged.</p> <p>(2) Check the transmission slide plates on the X and Y axis. If the slide plate can wobble loosely, they may need readjustment.</p> <p>(3) Check the springs on the X and Y transmission slide plates to ensure that they are compressed and fully engaged.</p> <p>(4) Contact CAMaster Technical Support for more assistance.</p>
Soft Limit Errors	<p>(1) The CNC system was commanded to move beyond its defined soft limits. Ensure that the commanded GCode exists within the safe operational areas of the CNC system.</p> <p>(2) Change the X and/or Y origin(s) to relocate the starting origin of the program to fit on the CNC system.</p> <p>(3) Contact CAMaster Technical Support for more assistance.</p>
Tool height is inconsistent between tools	<p>(1) Ensure that every tool used in the program is measured by loading each tool and clicking the Measure Tool button.</p> <p>(2) For specialty tooling with small diameters or pointy tips, manually measuring the tool height offset with a specialized tooling block may be required.</p> <p>(3) Check the tool collet and ensure that it is properly tightened to the correct torque specification. Additionally, check the tool collet for any dirt, debris, or damage.</p> <p>(4) Check the level of the tool measure switch in relation to your spindle. If the tram of the top of the switch is off from your spindle, different diameter tooling may register at different heights.</p> <p>(5) Contact CAMaster Technical Support for more assistance.</p>
Chatter marks are present	<p>(1) Ensure that the material is held down tightly without any</p>

on the finished part(s)	<p>play.</p> <p>(2) Check the spindle RPM, feed rate, and cutting depth and ensure that they are correct for this specific application.</p> <p>(3) Check the tooling to ensure that all cutting edges are sharp and free of wear.</p> <p>(4) Check the tool collet and ensure that it is properly tightened to the correct torque specification. Additionally, check the tool collet for any dirt, debris, or damage.</p> <p>(5) Check the distance the tooling is chucked into the collet. Using longer tooling than required can cause chatter and tool marks. Additionally, consider using long reach tooling or long flute tooling for applications where longer tool lengths are required.</p> <p>(6) Research Climb versus Conventional cutting and its effects of cut quality, dimensionality, and cutter life.</p> <p>(7) Check the CNC system for a loose mechanical axis (See “Loose movements on a single axis” above).</p> <p>(8) Check with the tooling manufacturer to ensure that the tooling is the correct choice for the job.</p> <p>(9) Contact CAMaster Technical Support for more assistance.</p>
Can I update Windows?	<p>Security Updates ONLY. The CAMaster Centroid system currently ships with Windows 11 pre-installed. All security updates or feature updates for Windows 11 should be installed when available, but do not update to newer versions of Windows when they become available. Contact CAMaster Technical Support for more assistance.</p>
Can I install 3 rd party applications on my CNC system control PC?	<p>While simple programs such as Google Chrome or Notepad++ do not normally cause an issue with the operation of the CNC system, other programs may cause issues including: (a) Reducing the available system resources dedicated to CNC12 or (b) restricting the network traffic between the control PC and the controller. CAMaster does not support control PC’s that have any 3rd party programs installed.</p>
Can I connect my control PC to a wireless network?	<p>Yes. Every Centroid control PC comes with a built-in Wi-Fi antenna that customers can use to connect to an available wireless network. This connection is suitable for internal or external network access depending on customer preference. Additionally, CAMaster Technical Support encourages connecting to an available and secure wireless network for cases where remote access is required to allow CAMaster Technical Support to diagnose any issues or to install machine firmware updates. CAMaster is not responsible for any unsanctioned wireless network usage by the customer or operator.</p>
Can I connect my control	Yes, but CAMaster does not provide the control PC with an

PC to an external wired network?	available ethernet adapter. It is recommended to buy a USB to Ethernet adapter to achieve this connection. Under no circumstances should the existing network cable be disconnected from the control PC. CAMaster does not support external wired networks and any changes made to the control PC are the customer's responsibility. Technical issues occurring from the addition of an external wired network are not covered by CAMaster Technical Support.
----------------------------------	--

For any other question or concerns, please contact CAMaster Technical Support via one of the methods below:

Phone: 770-334-2144 (Please leave a voicemail if no answer)

Email: support@camaster.com