

# Installation and Operation Instructions

## Onefinity CNC ORIGINAL Series Models

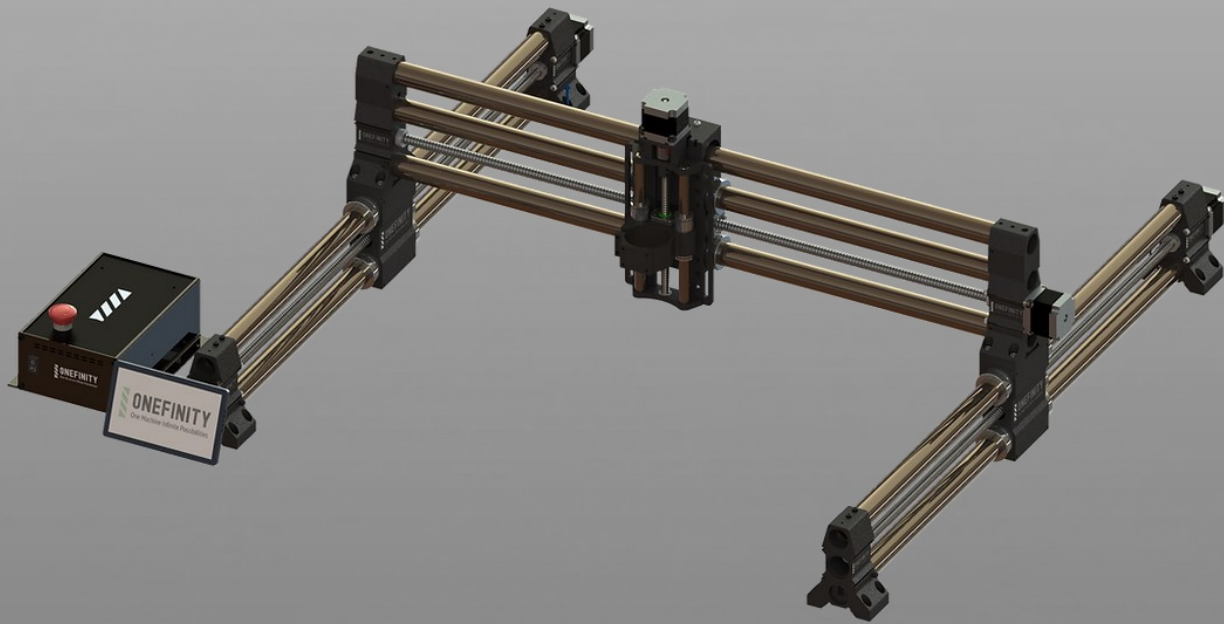

General Notes	3
Safety Rules	4-9
Description	10
Anatomy of the Onefinity	11
Anatomy of the Z-Slider	12
Anatomy of the Controller	13
Identifying Axis on the Onefinity	14
Specifications and Features	15
Machine Dimensions	16
Assembling Instructions	19-32
Spindle/Router Installation	33
Wasteboard	34
Maintenance	35-36
Loading a program	37-38
Adjusting Stall Homing	39
Reset Button (Soft E-Stop)	40
Touch Probe Fine Tuning	41
Joypad Layout and Controls	42
Onefinity Warranty Policy	43-45
Contact Us	46

This manual serves to familiarize you with your Onefinity CNC machine and provide all necessary information required to operate the machine safely and professionally.

This manual is applicable for the Onefinity Journeyman, Onefinity Woodworker and Onefinity Machinist, hereafter referred to as Onefinity.

Please completely read this manual before the first commissioning of your machine. In order to minimize the risks of injury and/or material damages, please only commission the machine and the corresponding control when you are sure that you have completely understood these instructions!

Please contact us for any further questions. Please find our contact info on page 36 of these instructions.

Please always keep these instructions nearby the machine. You should always have them readily available when you want to look up something.

Please only use this machine according to its intended use.

We cannot be held liable for persons or material damages which are caused by using the machine other than the intended use, handling which does not comply with the common use of a CNC machine or if safety regulations are not obeyed

In case of improper maintenance (**refer to page 28**) and/or wrong operation of the individual components your warranty claims are omitted.

We reserve the right to perform future technical enhancements on the machine and its components.

## General Instructions:

These operating instructions explain the Onefinity and the correct handling of the CNC system. Please read these operating instructions and accompanying documents in their entirety before commissioning of the system in order to become familiar with the characteristics and the operation of the product. The improper operation of the CNC gantry milling system can lead to damage to the product and property and can cause serious injuries, electric shock and / or fire. It is imperative to adhere to the safety instructions listed in these operating instructions at all times. Should you have any questions or concerns prior to initial use of the CNC system or the need for further information, do not hesitate to contact us prior to the commissioning of the CNC system.

## Safety Instructions and Protective Measures:

(General Safety Warnings for the Use of Power Tools )

### Work Area Safety

**NOTICE:** Keep work area clean and well lit. Cluttered or dark areas invite accidents.



**Caution:** Do not operate the power tool in explosive atmospheres, such as in the presence of flammable liquids, gases or dust. Power tools create sparks which may ignite the dust or fumes.

**NOTICE:** Keep children and bystanders at a distance while operating a power tool. Distractions can cause you to lose control and can result in accidents.



**Caution:** Operate the Onefinity only in interior spaces on a solid, horizontal table or workbench.

### Electrical Safety:



**Warning:** Power tool plugs must match the outlet. Never modify the plug in any way. Do not use any adapter plugs with grounded power tools. Unmodified plugs and matching outlets will reduce the risk of electric defects and malfunctions.



**Warning:** Do not expose power tools to moisture. The power tool is only suitable for indoor use. Water entering a laser tool will increase the risk of electric shocks.

## Personal Safety:



**Caution:** Stay alert, watch what you are doing and use common sense when operating a power tool. Do not use a power tool while you are tired and/or under the influence of drugs, alcohol or medication. A moment of inattention while operating a power tool may result in serious personal injury.

**NOTICE :** All persons who operate the power tool must have read and fully understood all relevant safety and operating instructions. Misunderstanding may result in personal injury.



**Caution:** Use personal protective equipment. Always wear eye protection. Protective equipment, such as a suitable dust mask or ear protection, reduces the risk of injuries.

**NOTICE:** Dress properly. Do not wear loose clothing or jewelry. Pin your hair above your shoulders so that it cannot get caught in the Ball Screws and linear guides or moving parts.



**Caution:** This tool is controlled by a computer. During operation, it cannot be controlled directly. Lack of caution or expertise as well as program errors can lead to unexpected movements.



**Caution:** Do not touch the insertion tools or motors as they can heat up significantly during operation.



**Caution:** Never place any parts of the tool or accessories in the mouth as this can lead to serious injuries.

## Protective Measures:

The Onefinity has been constructed for advanced users and is only to be operated by technically skilled persons above the age of 16. The CNC gantry milling system as well as associated tools, small parts and electrical components are to be stored outside the reach of children. The operator is solely responsible for understanding and reading the machine user guide and all relevant operating instructions in their entirety. These documents should always be stored in immediate vicinity of the machine. The manufacturer's instructions concerning the CNC machine and the tools, such as the milling spindle, are to be adhered to. The CNC gantry milling system is only to be used in a technically perfect condition which is to be ensured prior to each operation. The emergency switch as well as, if applicable, additional safety devices, always need to be easily accessible and fully functional. The use of liquids with the machine, such as the application of a coolant pump, is prohibited as it can damage the electronics. The use of lubrication systems is allowed. Please take into consideration that in this case the MDF machine table is not used as its MDF panels can swell and, thus, be destroyed.

# Safety Rules

## Use of the Power Tool:



**Caution:** Do not alter or misuse the tool. Any alteration or modification is a misuse and may result in serious personal injury.



**Caution:** Disconnect the plug from the power source before you make any adjustments, change accessories, or store the tool. Such preventative safety measures reduce the risk of starting the power tool accidentally.



**Caution:** Store idle power tools out of the reach of children and do not allow persons unfamiliar with the laser tool or these instructions to operate the power tool. Power tools are dangerous in the hands of untrained users.

**NOTICE:** Use the power tools, accessories etc. in accordance with these instructions, taking into account the working conditions and the work to be performed. Use of the power tool for operations different from those intended could result in a hazardous situation with high probability of superficial injury.

**NOTICE:** Do not reach into the area of the rotating insertion tools. The proximity of the rotating tools to your hand may not always be obvious.

**NOTICE:** Never use dull or damaged insertion tools. Sharp bits must be handled with care. Damaged bits can snap during use. Dull bits require more force to cut the tool, possibly causing the bit to break.

**NOTICE:** The speed and feed of the bit when carving, routing or cutting is very important. Always observe the recommended speed and feed for the particular bit.



**Caution:** If the workpiece or bit becomes jammed or bogged down, turn the power tool "OFF" by the switch. Wait for all moving parts to stop and unplug the tool, then free the jammed material. If the switch to the tool is left "ON", the tool could restart unexpectedly causing serious personal injury.

**NOTICE:** Do not leave a running tool unattended, turn power off. Only when tool comes to a complete stop and is disconnected from the mains it is safe.



**Caution:** Do not touch the bit or collet after use. After usage bit and collet are too hot to be touched with bare hands.

**NOTICE:** Do not allow familiarity gained from frequent use become commonplace. Always remember that a careless fraction of a second is sufficient to inflict severe injury.



**Caution:** When using the end mills, V-bits or cutters, always have the workpiece securely clamped. Never attempt to hold the workpiece with your hands while using any accessories. These tools can jam easily in the material, and can kickback, causing loss of control resulting in serious injury.

## Care of the Power Tool:

**NOTICE:** Maintain the tools. Check for misalignment or binding of moving parts, breakage of parts and any other conditions that may affect the power tool's operation. If damaged, have the power tool repaired before use. Many accidents are caused by poorly maintained power tools.

## Additional Safety Instructions



**Caution:** Depending on the application field of the machine (private or commercial), observe the applicable occupational safety and health, safety and accident prevention and environmental regulations.



**Caution:** Some dust created by cutting, milling or other construction activities contains chemicals known to cause cancer, birth defects or other reproductive harm. Some examples of these chemicals are: Lead from nonferrous metals with lead content, carbonate from carbon fiber, arsenic and chromium from chemically treated lumber. Your risk from exposures to these varies, depending on how often you perform this type of work. To reduce your exposure to these chemicals, work in a well ventilated area, and work with approved safety equipment, such as those dust masks that are specially designed to filter out microscopic particles.

Safely dispose of milling debris — recycle or safely dispose of milling debris and dust, keeping in mind flammability, (potential) spontaneous combustion, and chemical considerations. Even natural materials can have surprising implications for disposing of them, *e.g.*, walnut wood dust is allelopathic (inhibits plant growth) and an irritant to the skin and breathing tract and potentially poisonous to some animals in addition to the typical spontaneous combustion hazard which sawdust poses.

## Personal Protective Equipment:

When working with the CNC gantry system, the operator has to wear at least the following personal protective equipment and has to be compliant with the below-mentioned safety aspects: - Safety goggles for protecting the eyes against flying chips etc. - Ear protection for protecting the ears against sound and noise. - No wearing of clothes which can get caught in the machine, such as ties, scarves, wide sleeves etc. Additionally, jewelry and especially long necklaces and rings are to be dispensed with. - Shoulder-length or longer hair is to be secured with a hairnet or a hat to prevent it from getting caught in the linear guides and / or rotating tools. Prior to all adjustments to the machine, its control or system-guided tools, such as the Milling Motor, the Drag Knife or the Hot Wire Cutter, the plug is to be disconnected from the power source. Never hold the workpiece to be processed with your hands. It is mandatory that the workpiece is securely fixed on the machine table. Otherwise there exists a high risk of injuries!

## Emergency Stop Switch :

The emergency stop is located on the top of the Controller housing. In order to be able to intervene at all times, the emergency stop has to be positioned in a suitable place. The controller must be located so it can be reached from any possible operator position.





By pressing the emergency stop switch, the emergency stop is triggered. The control is interrupted. Additionally, the control software receives the signal to stop the operating process. The machine stops immediately.

**ATTENTION!** The emergency stop switch can only effect the stop of all components if these components are electronically connected with the emergency stop switch.

If you want to use a system-guided tool, such as a milling and drilling motor, that features a separate ON / OFF switch and that is NOT controlled via the PC, you have to make sure that it is expertly connected with the emergency stop switch. If you do not comply with these requirements, the system-guided tool will continue to run although you have activated the emergency stop switch leading to a high risk of personal injury and damage to property! If you have any questions, please do not hesitate to contact us!

## Residual Risk:

Despite all safety precautions against the contact with rotating or hot tools and the protection from crushes, a residual risk remains due to a careless handling and automatic movements of the CNC system.

Symbol	Name	Explanation
	Symbol: Read manual	Alerts user to read manual BEFORE first commissioning
	Symbol: Wear ear protection	Alerts user to wear a hearing protector
	Symbol: Wear safety glasses	Alerts user to wear protective glasses
	General warning symbol	Alerts user to warning messages



## Read the following carefully before operating the machine.

1. Keep the working area clean and ensure adequate lighting is available.
2. Do not wear loose clothing, gloves, bracelets, necklaces or ornaments.
3. Do wear face, eye, respiratory and body protection devices as indicated for the operation or environment.
4. Ensure that the power is disconnected from the machine before tools are serviced or any attachment is to be fitted or removed.
5. Never leave the machine with the power on.
6. Do not use dull, gummy or cracked cutting tools.
7. Ensure that the keys and adjusting wrenches have been removed and all the nuts and bolts are secured.
8. Hearing protection — ear plugs or muffs, for long jobs doubling up on ear plugs or muffs may be desirable. Hearing damage is cumulative and irreversible, so one should err on the side of caution
9. Use care when handling endmills, both to avoid being cut, and to avoid damaging them. Handling them with suitable gloves, or using a cloth to avoid contaminating them is recommended. Inspect them carefully before each use and ensure that they are securely held by the collet.
10. Never leave the machine running unattended/unsupervised.
11. Always inform someone before operating the machine and check in with them after successfully completing work.

## Workspace:

The workspace needs to provide enough space around the Onefinity CNC for the machine to work comfortably and to be able to fully use its traveling paths. Additionally, a safe distance to possibly nearby positioned machines is to be maintained. The location of the machine as well as the workplace surrounding the machine has to be sufficiently illuminated.

As with all machinery, there are certain hazards involved with the operation and use of your machine. Using it with caution will considerably lessen the possibility of personal injury. However, if normal safety precautions are overlooked or ignored, personal injury to the operator may result. If you have any questions relating to the installation and operation, do not use the equipment until you have contacted your supplying distributor.

## Description

The Onefinity is a multifunctional CNC gantry milling system for the permanent and regular processing of wood, plastics and non-ferrous metals.

Thanks to the innovative design, how and where you carve is limitless! Feel like carving an intricate inlay into your dining table, no problem? Have a small shop where space is limited, Onefinity has been design to be quickly dismantled and stored!

With Fast Travel Precision Ball Screws, gone are the stretchy belts and high maintenance Lead Screws found on similarly priced machines. Hardened Steel Hollow Linear Motion Shafts means no more plastic wheels that require frequent adjustment and a powerful CNC controller with built in CAM software and HD Touch Display allows for operation without a computer!

The machine has three axes which are offset by 90°. This way, it is possible to travel to any point within the working space. Each axis is equipped with up to two stepper motors and stall homing. The stepper motors drive the movable axes elements via precision ball screws. The position of the axis is determined during the reference run (homing cycles), at the beginning of the job, with the aid of the stall homing. The machine table may consist of any solid flat surface big enough to mount the Rails and Controller. The Onefinity consists of the following, sometimes optional, components: - Onefinity Journeyman, Woodworker, Machinist; - electronic control unit in a separate aluminum housing, Z-Slider, Wire harness and Hardware.

# Anatomy of the Onefinity

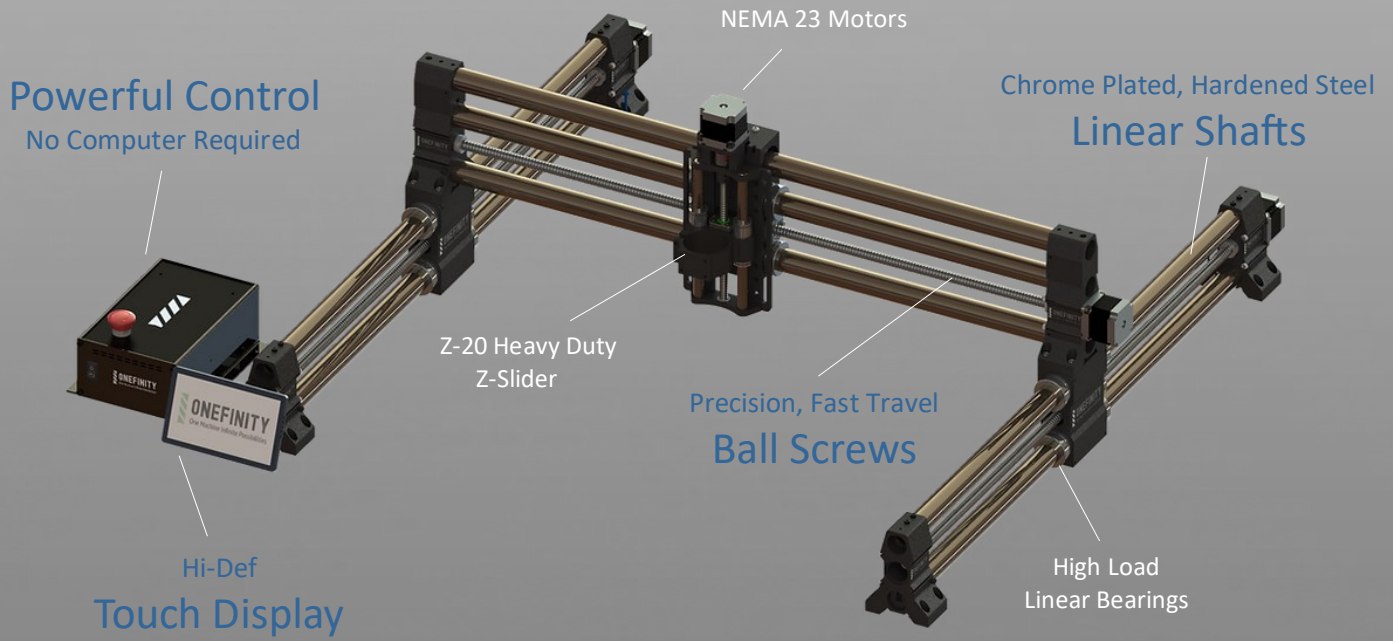

# Anatomy of the Z-Slider

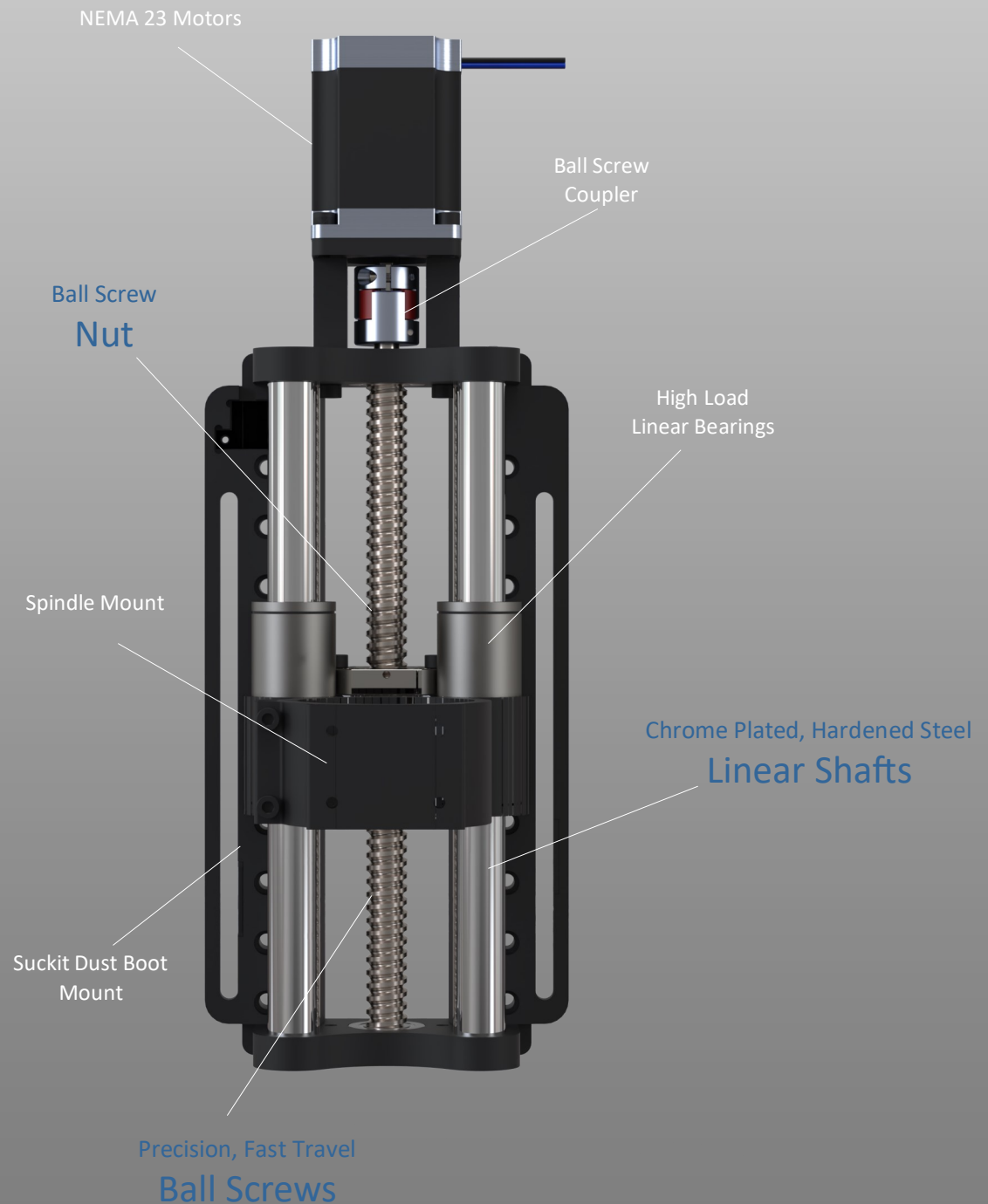

# Anatomy of the Controller

**Important note:** The Onefinity BB Controller is based on the Buildbotics open sourced CNC controller. To learn all of the controllers capabilities please visit: [www.buildbotics.com](http://www.buildbotics.com)



# Identifying Axis on the Onefinity

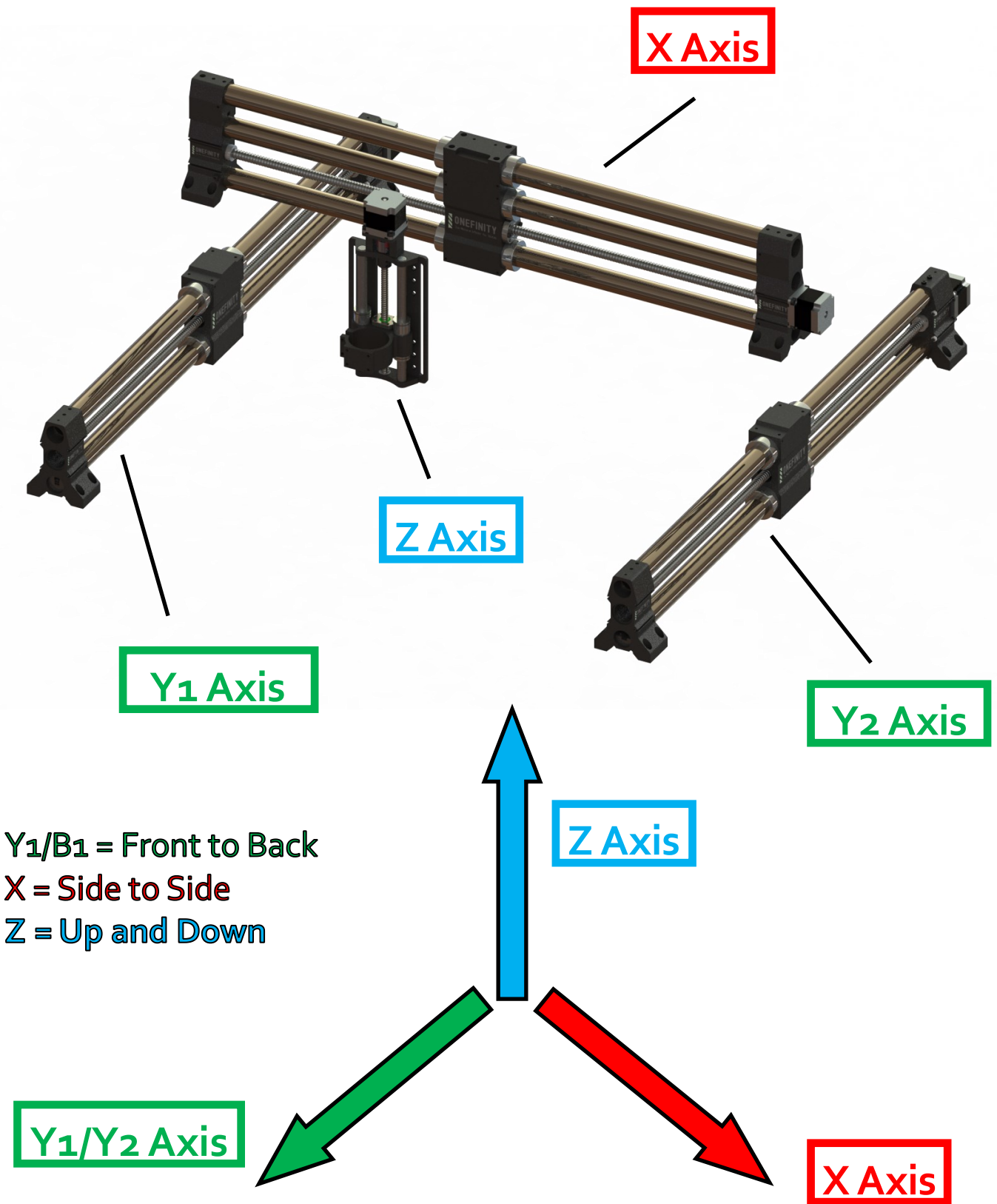

**General Disclaimer:**

While Onefinity has made every effort at the time of publication to ensure the accuracy of the information provided herein, product specifications, configurations, system/component/options availability are all subject to change without notice. Product design specifications and colours are subject to change without notice and may vary from those shown. Errors and omissions excepted. Images displayed are for illustration purposes only. The images are intended to help illustrate the product and its functions and are not indicative of actual relative differences.

# Specifications and Features

## Rapid Rate: All Onefinity CNC Machines

X Axis: 400 inches/min (accel 750 km/min<sup>2</sup>)

Y Axis: 400 inches/min (accel 750 km/min<sup>2</sup>)

Z Axis: 200 inches/min (accel 750 km/min<sup>2</sup>)

*Note: these are stock settings and in most cases can be increased*

## Cutting Area: Machinist Model

X Axis: 16- 1/4 inches

Y Axis: 16- 1/4 inches

Z Axis: 5 - 1/4 inches

## Cutting Area: Woodworker Models

X Axis: 32- 1/4 inches

Y Axis: 32- 1/4 inches

Z Axis: 5 - 1/4 inches

## Cutting Area: Journeyman Model

X Axis: 48- 1/4 inches

Y Axis: 32- 1/4 inches

Z Axis: 5 - 1/4 inches

## Specifications:

16mm Ball Screws on X and Y axis

12mm Ball Screw on Z axis

4 motor driver channels

7 inch Hi-Def Touch Screen

Up to 256 microstepping

250k steps/second on each motor output

Chrome plated, hardened steel linear shafts on all axis

## Machinist Dimensions (see diagram):

A: 29 - 3/8 inches

B: 21- 3/4 inches

C: 5 - 1/2 inches

D: Adjustable: 4 - 3/32 inches or  
5 - 7/16 inches

Depth (not including display) 29 - 3/8 inches

## Woodworker Dimensions (see diagram):

A: 45 - 3/8 inches

B: 37 - 3/4 inches

C: 5 - 1/2 inches

D: Adjustable: 4 - 3/32 inches or  
5 - 7/16 inches

Depth (not including display) 45 - 3/8 inches

## Journeyman Dimensions (see diagram):

A: 61 - 3/8 inches

B: 53 - 3/4 inches

C: 5 - 1/2 inches

D: Adjustable: 4 - 3/32 inches or  
5 - 7/16 inches

Depth (not including display) 45 - 3/8 inches

## Feature:

Low profile Z-Slider

Fast set-up (less than an hour)

WiFi

Quick connect wiring

4 USB ports

Smooth S-curve acceleration

Control and configure from your web browser

Remote video monitoring (optional)

Wired (ENet) or wireless (WiFi) networking

2 Switched load outputs

PWM & RS485 (VFD) spindle control

3D Visualization of GCode paths

Accurate ETA and time estimates

## Optional Accessories:

Suckit Dust Boot

Oops Clamps

Quick Change Waste Board Frame

Rolling-Folding Stand

Wall Mount System

Any Surface Leveling Feet

Stiffy (3rd X-Rail)

Touch Probe

Laser

Vacuum Hose Boom

Joystick

Webcam

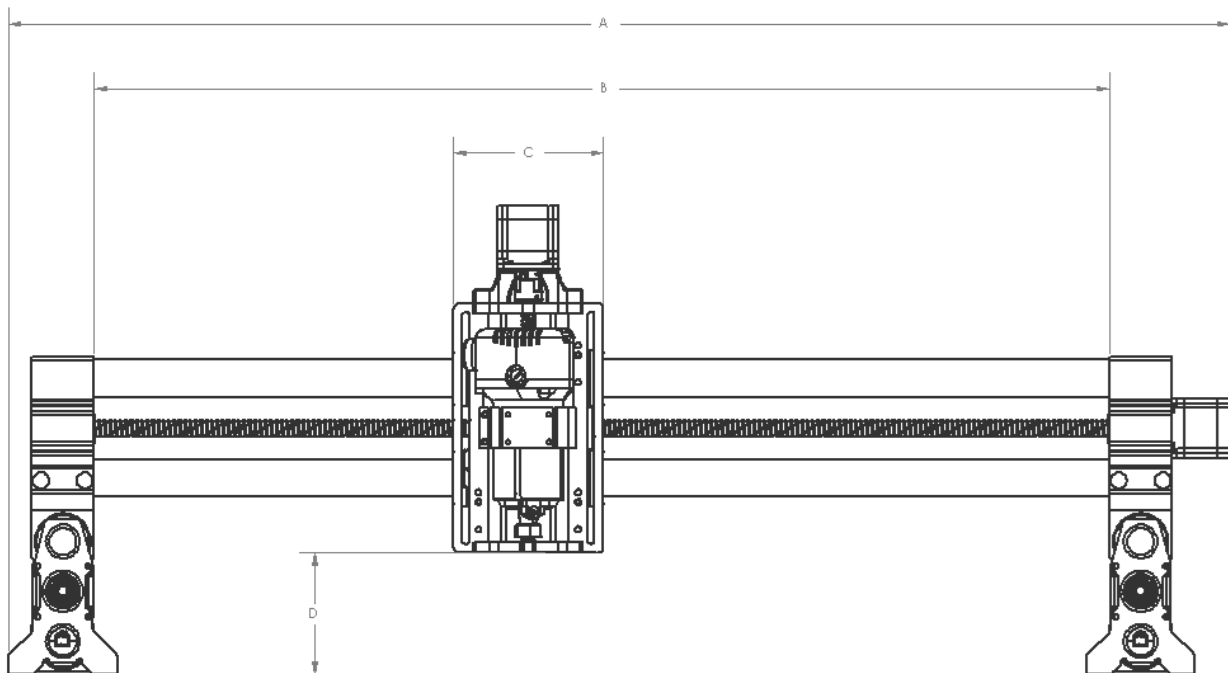

## General Disclaimer:

While Onefinity has made every effort at the time of publication to ensure the accuracy of the information provided herein, product specifications, configurations, system/component/options availability are all subject to change without notice. Product design specifications and colours are subject to change without notice and may vary from those shown. Errors and omissions excepted. Images displayed are for illustration purposes only. The images are intended to help illustrate the product and its functions and are not indicative of actual relative differences.



**General Disclaimer:**

While Onefinity has made every effort at the time of publication to ensure the accuracy of the information provided herein, product specifications, configurations, system/component/options availability are all subject to change without notice. Product design specifications and colours are subject to change without notice and may vary from those shown. Errors and omissions excepted. Images displayed are for illustration purposes only. The images are intended to help illustrate the product and its functions and are not indicative of actual relative differences.





**General Disclaimer:**

While Onefinity has made every effort at the time of publication to ensure the accuracy of the information provided herein, product specifications, configurations, system/component/options availability are all subject to change without notice. Product design specifications and colours are subject to change without notice and may vary from those shown. Errors and omissions excepted. Images displayed are for illustration purposes only. The images are intended to help illustrate the product and its functions and are not indicative of actual relative differences.



**General Disclaimer:**

While Onefinity has made every effort at the time of publication to ensure the accuracy of the information provided herein, product specifications, configurations, system/component/options availability are all subject to change without notice. Product design specifications and colours are subject to change without notice and may vary from those shown. Errors and omissions excepted. Images displayed are for illustration purposes only. The images are intended to help illustrate the product and its functions and are not indicative of actual relative differences.

# Assembly Instructions

The following instructions detail how to install your Onefinity CNC Machine. Please read these entire instructions carefully. If you have any problems or do not understand these instructions please contact us at support@onefinitycnc.com or 1-888 717 4242 for further assistance.

For step-by-step instructional video's and how-to's please visit our Youtube page at: <https://www.youtube.com/onefinitycnc>. **Note:** It is highly recommended that you view all of our assembly videos prior to attempting to assemble your Onefinity machine.

**Step 1:** Set Y-Rails (Red Arrows) on the bench and place them close to where you would like them to be installed. The Y rails are different from the X rail in that the top of the Y gantry (red) is keyed to fit the bottom of the X rail feet (red). The X rail has three linear tubes instead of two for added rigidity as well as it has a flat top on the gantry (green). This makes for an easy to align fit that ensures that your machine is properly assembled.

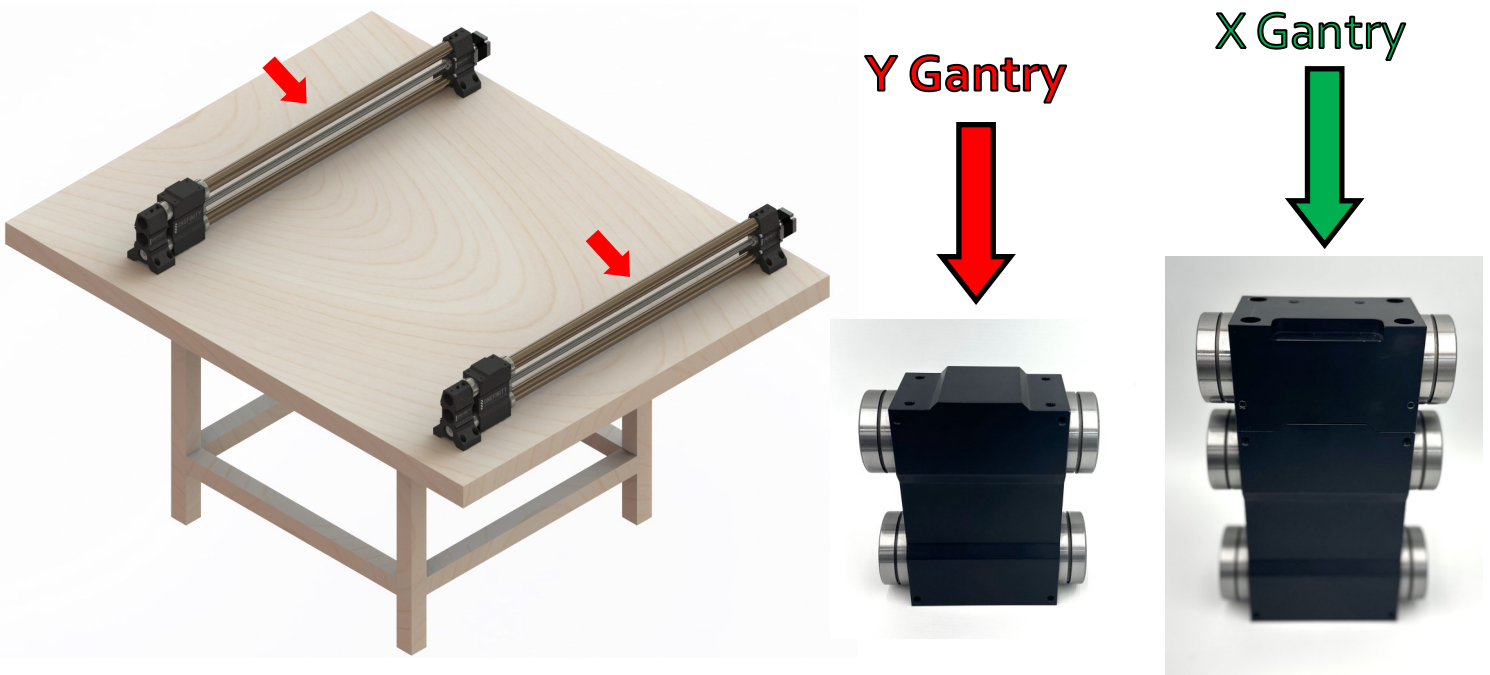

**Step 2:** Slide the Gantry assembly (Red Arrow) all the way to the front until it's tight to the Rail End (Blue Arrow). See below pictures. (Note: you can also turn the ball screw to get the Gantry Assembly to move to the front). **Important:** Make sure they are all the way to the front!



# Assembly Instructions

**Step 3:** Place the X-Rail (Green Arrow) on the Y-Rails Gantry Blocks (Red Arrows) with the motor on the right side of the rail.

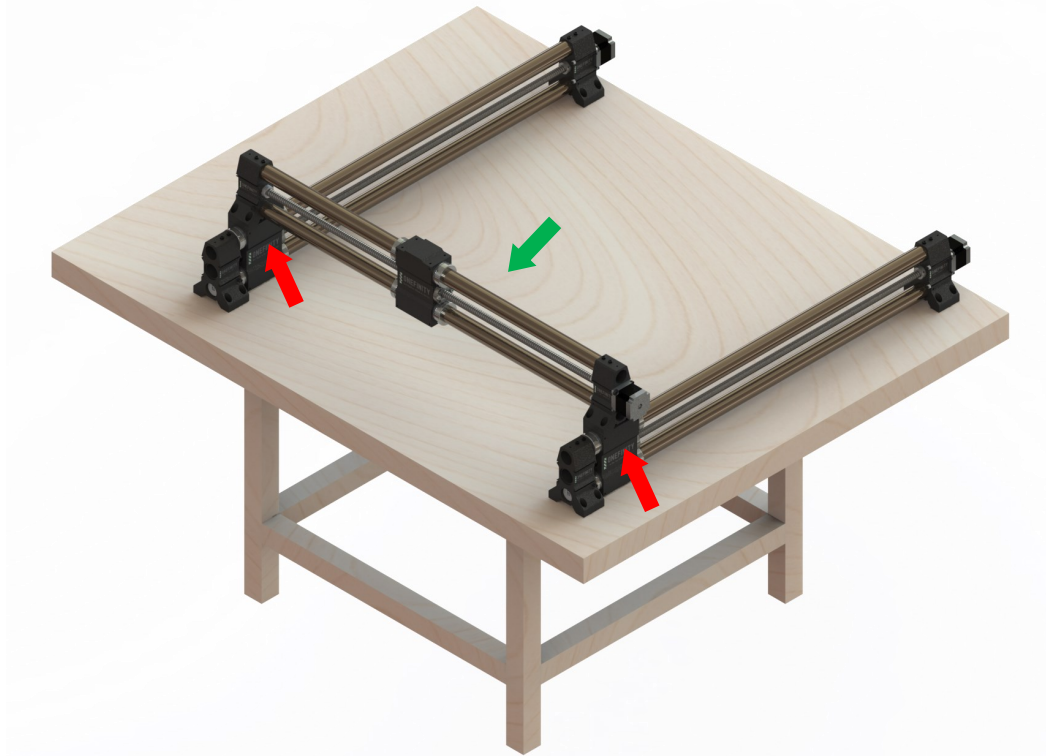

**Step 4:** Adjust Y-Rails (Red Arrows) until the Gantry Assemblies (Blue Arrows) are flush with X-Rail Ends (Green Arrows). **Note:** It is important that these parts are flush with each other before fastening together.

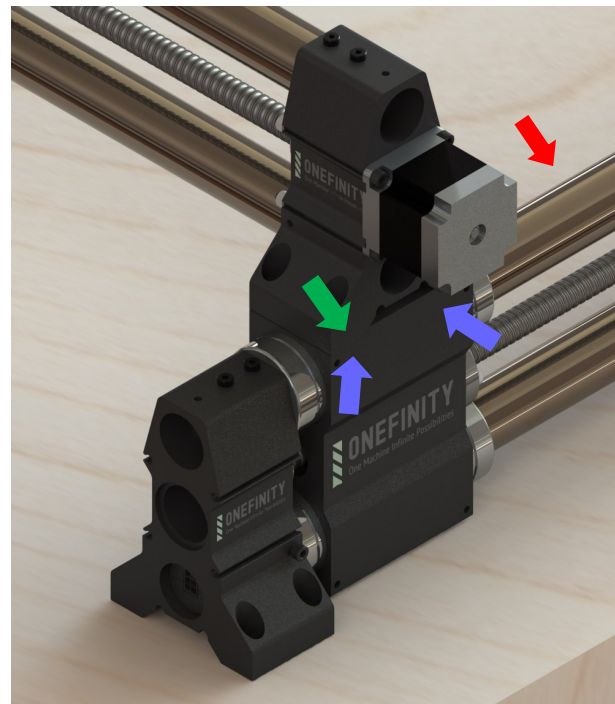
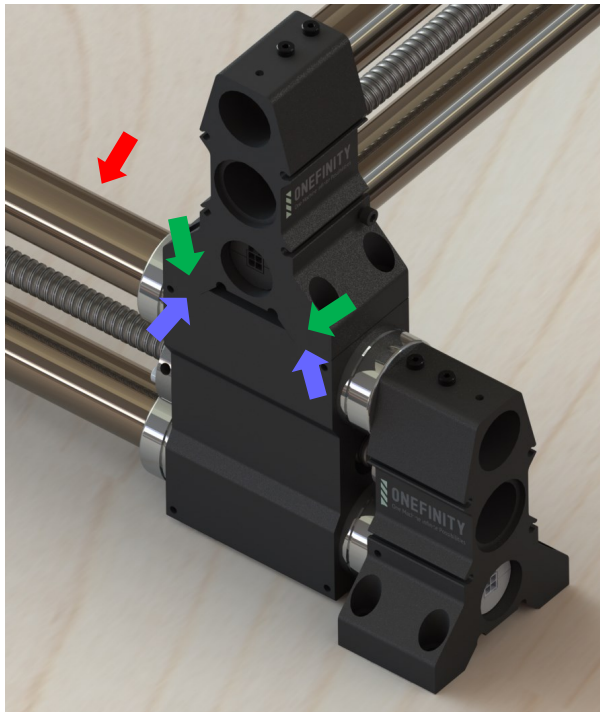

# Assembly Instructions

**Step 5:** Once you have ensured the Y-Axis Gantry Blocks and X-Axis Rails Ends are flush, fasten the front of the X-Rail to the Y-Axis using four (4) X-Rail Mounting Screws (Blue Arrows)

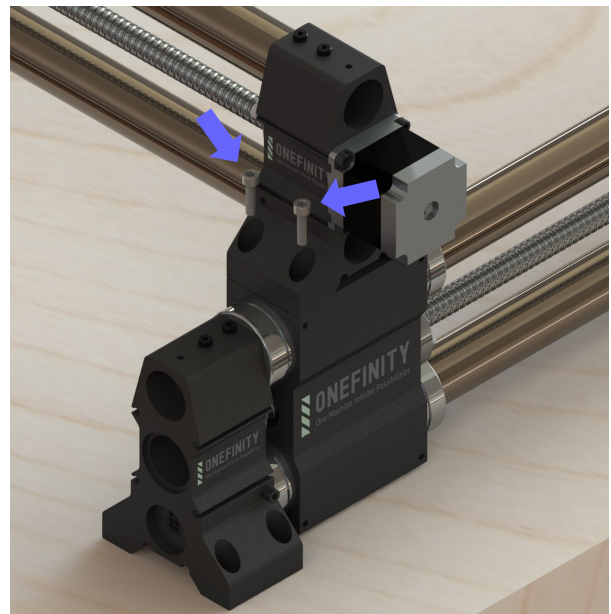
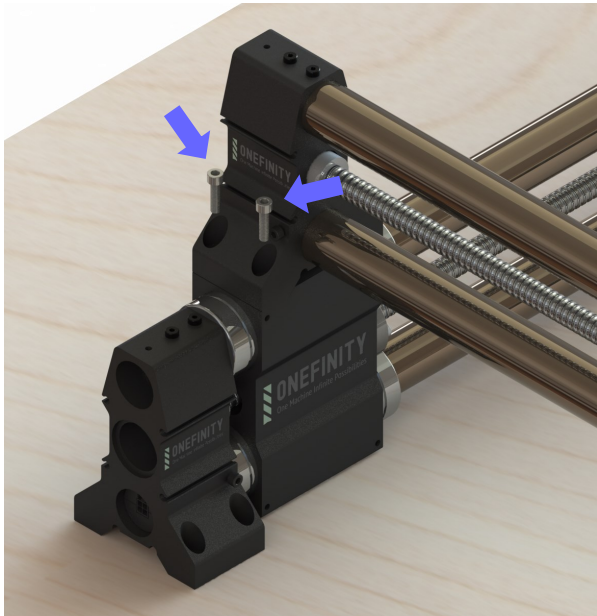

**Step 6:** Fasten the back of the X-Rail to the Y-Axis using the remaining four (4) X-Rail Mounting Screws (Blue Arrows)

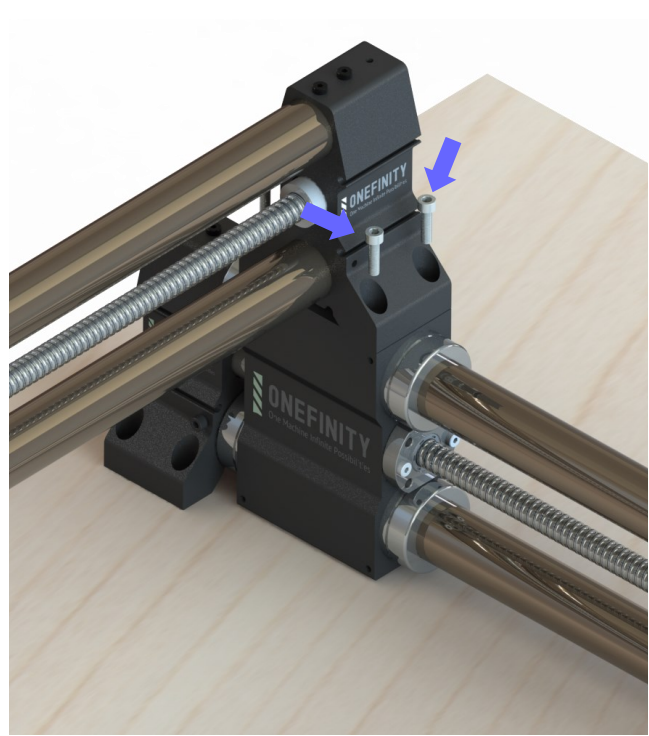
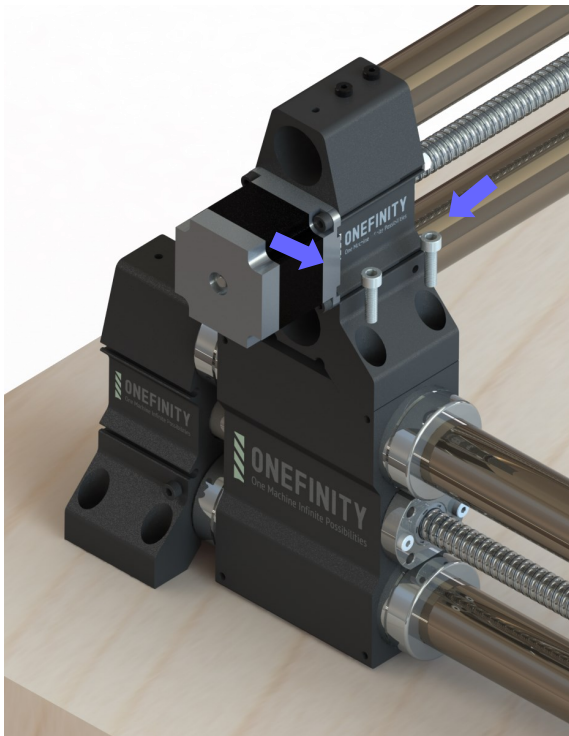

# Assembly Instructions

**Step 7:** Fasten the front of the Y-Rails to your table using only one (1) Y-Rail Mounting Screw per side (Red Arrow). You will use the remaining screws later.

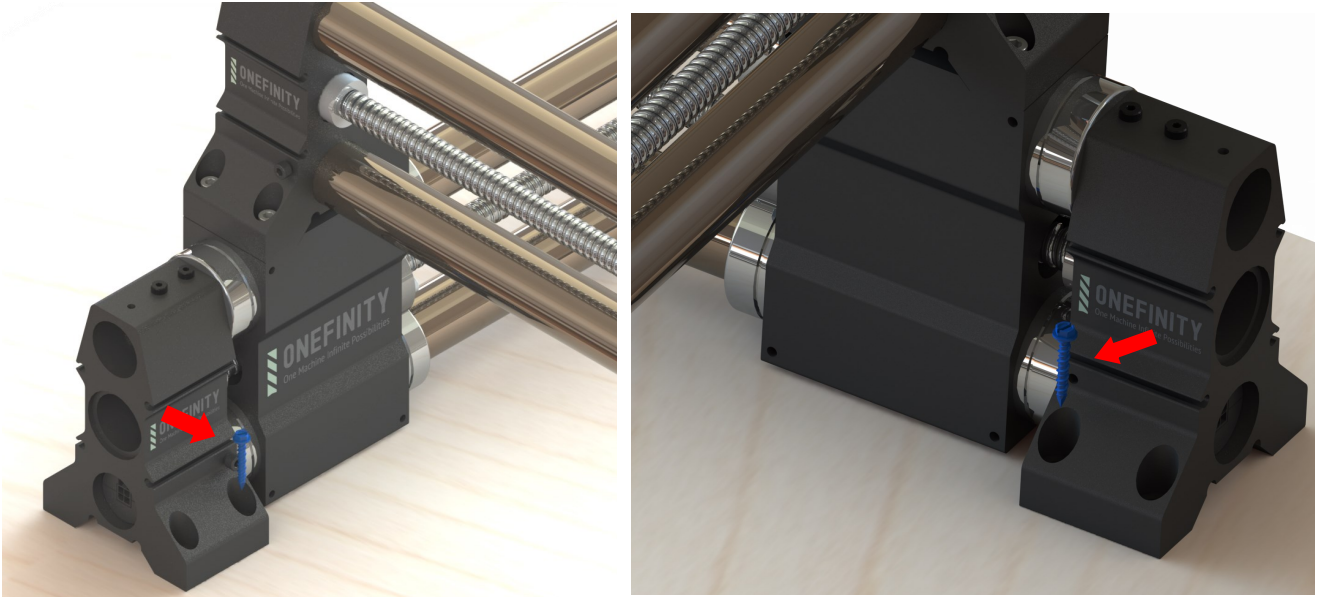

**Step 8:** Place the Controller on the left side of the machine as shown below.

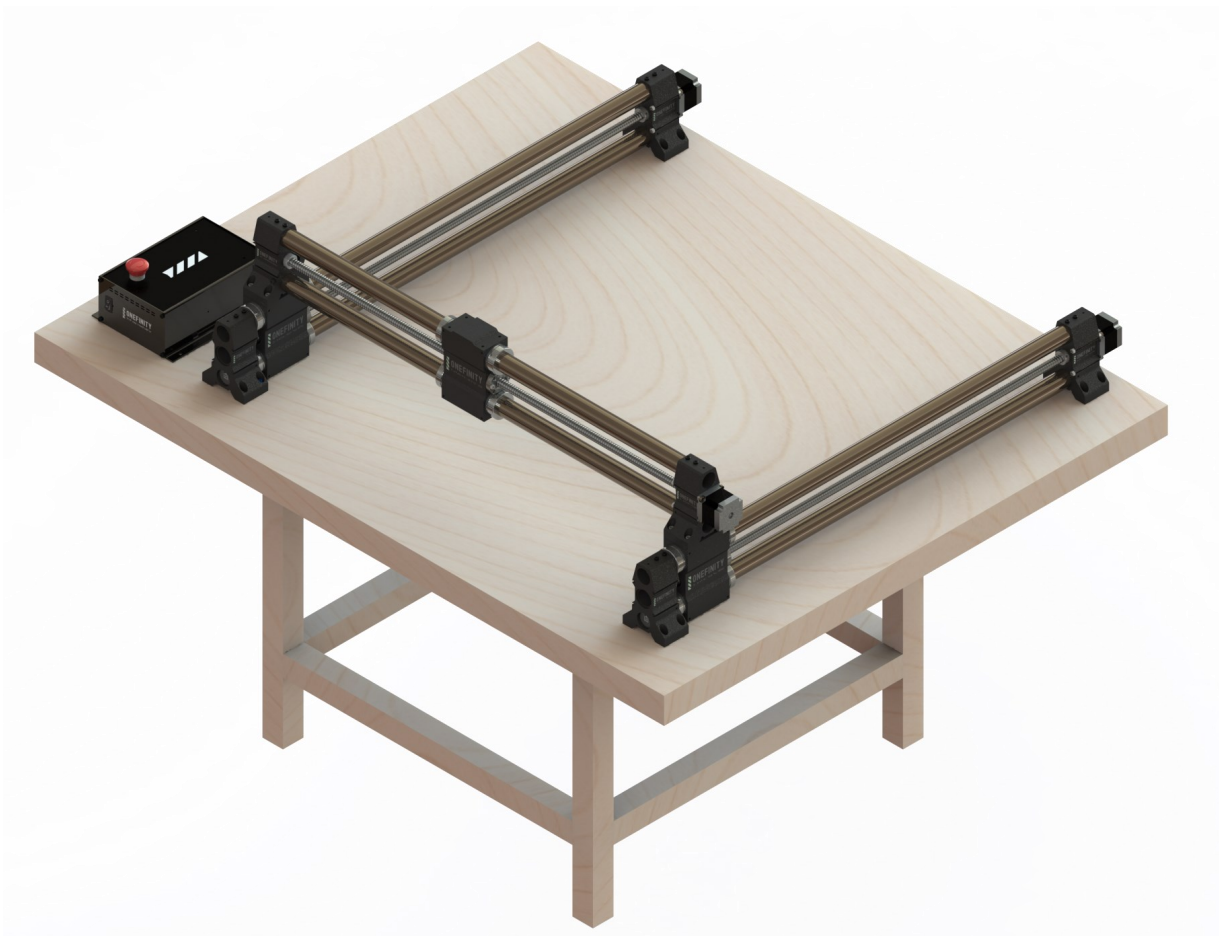

# Assembly Instructions

**Step 9:** Using the Display Mounting Hardware, mount the Display Mount to the front of the left side Rail End.

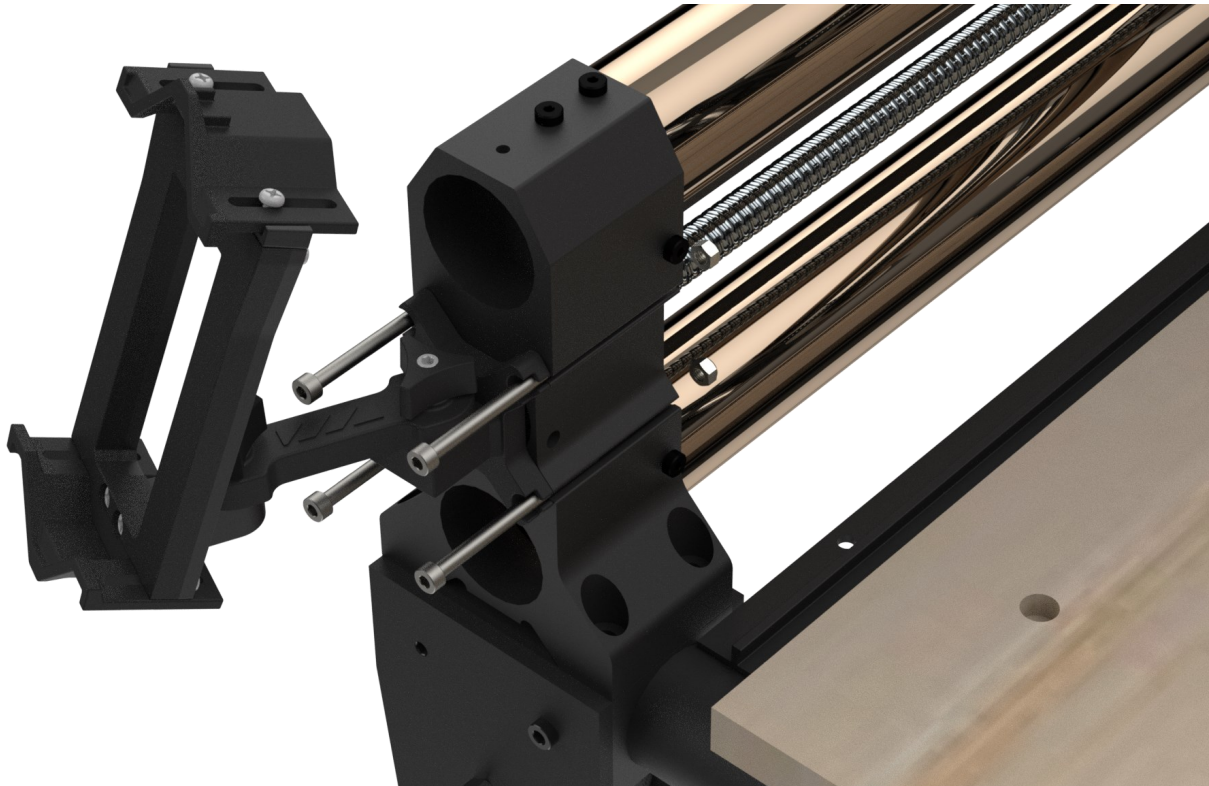

**Step 10:** Attach Display to Display Mount.

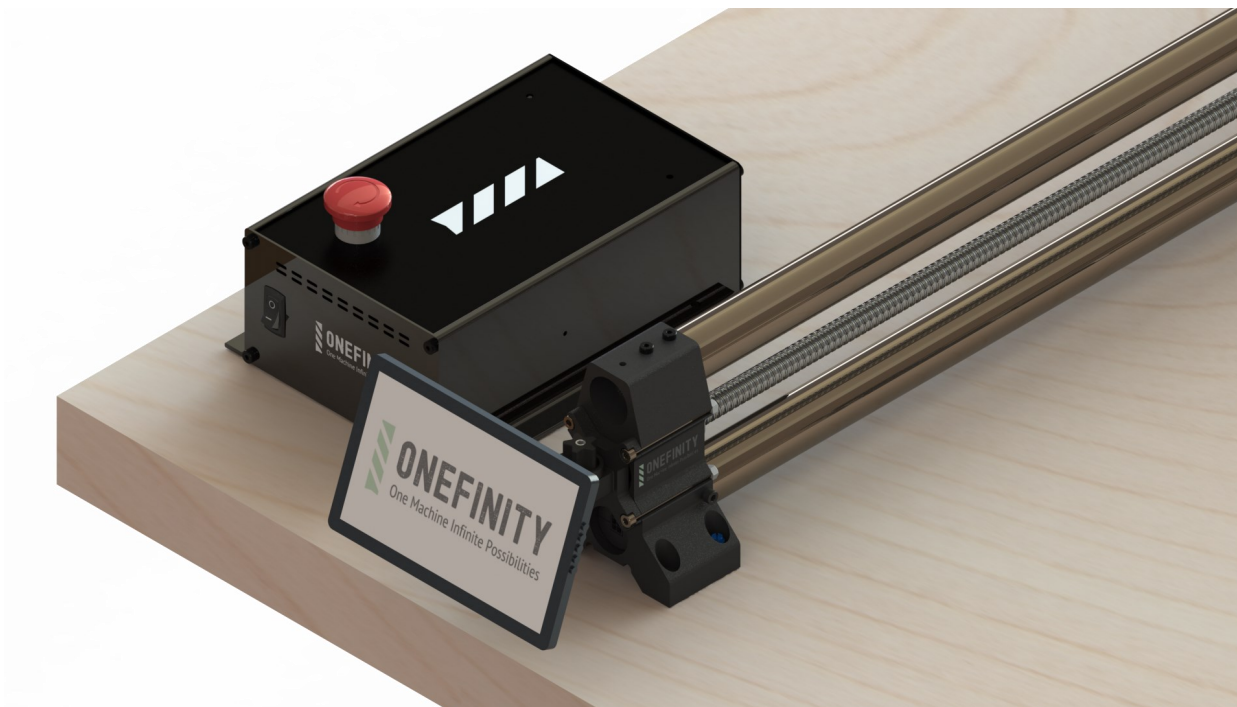

# Assembly Instructions (Wiring)

**Step 11:** It's now time to wire up your machine. We'll start with the Y-Axis's. Plug connector labelled **M1** into the controller port labelled **M1** (Green Arrow). Plug connector labelled **Y1** into the front of the right Y-Rail (Green Arrow). Plug connector labelled **M2** into the controller port labelled **M2** (Red Arrow). Plug connector labelled **Y2** into the front of the left Y-Rail (Red Arrow).

Connect the X-Rail by plugging connector labelled **MO** into the controller port labelled **MO** (Yellow Arrow). Plug connector labelled **X** into the side of the X-Rail (Yellow Arrow). Connect the Z-Axis by Plugging connector labelled **M3** into the controller port labelled **M3** (Blue Arrow). Plug connector labelled **Z** into the side of the X-Rail (Blue Arrow).

**Please note:** The small M connectors that plug into the back of the controller can be difficult to plug in. You may need to twist and wiggle them while pushing them in.

Plug one end of the power connector into the controller (Purple Arrow) and the other into a wall socket.

Connect the Touch Display using one of the USB ports (Pink Arrow) and the HDMI port (Grey Arrow) and connect the other ends to the Touch displays USB port (Pink Arrow) and HDMI port (Grey Arrow).

**Please ensure the CNC is mounted in a way that protects the wiring.**

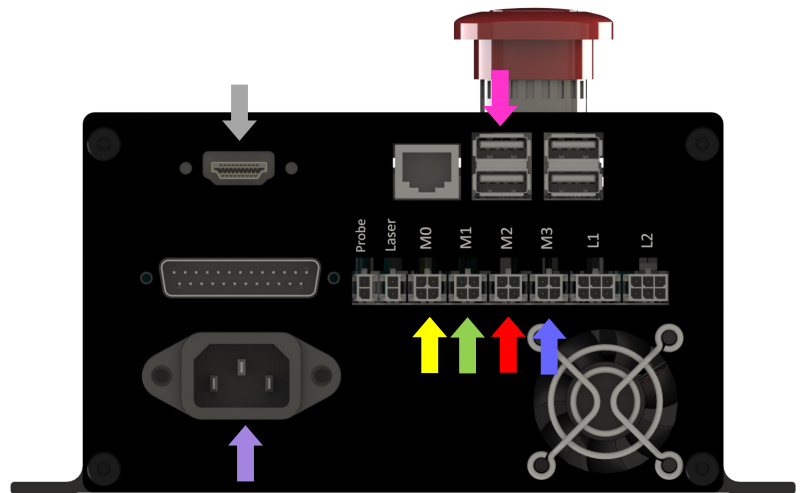

\* 7" wires connect on the LEFT side of the display, 8" and 10" models connect on the RIGHT

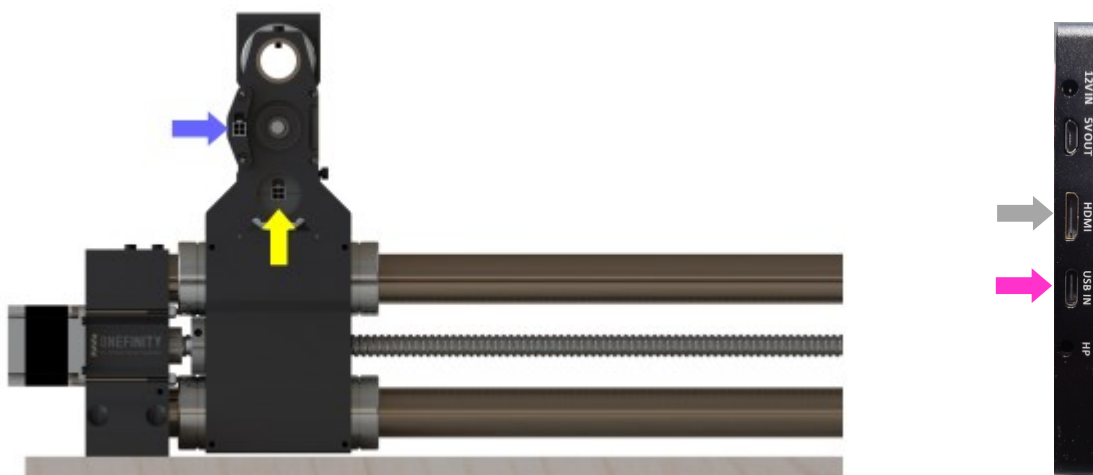
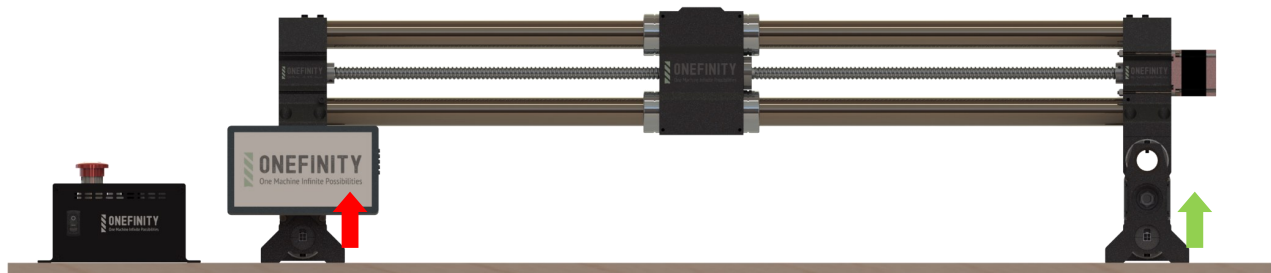



# Assembly Instructions (Wiring)

Pin out Diagrams:

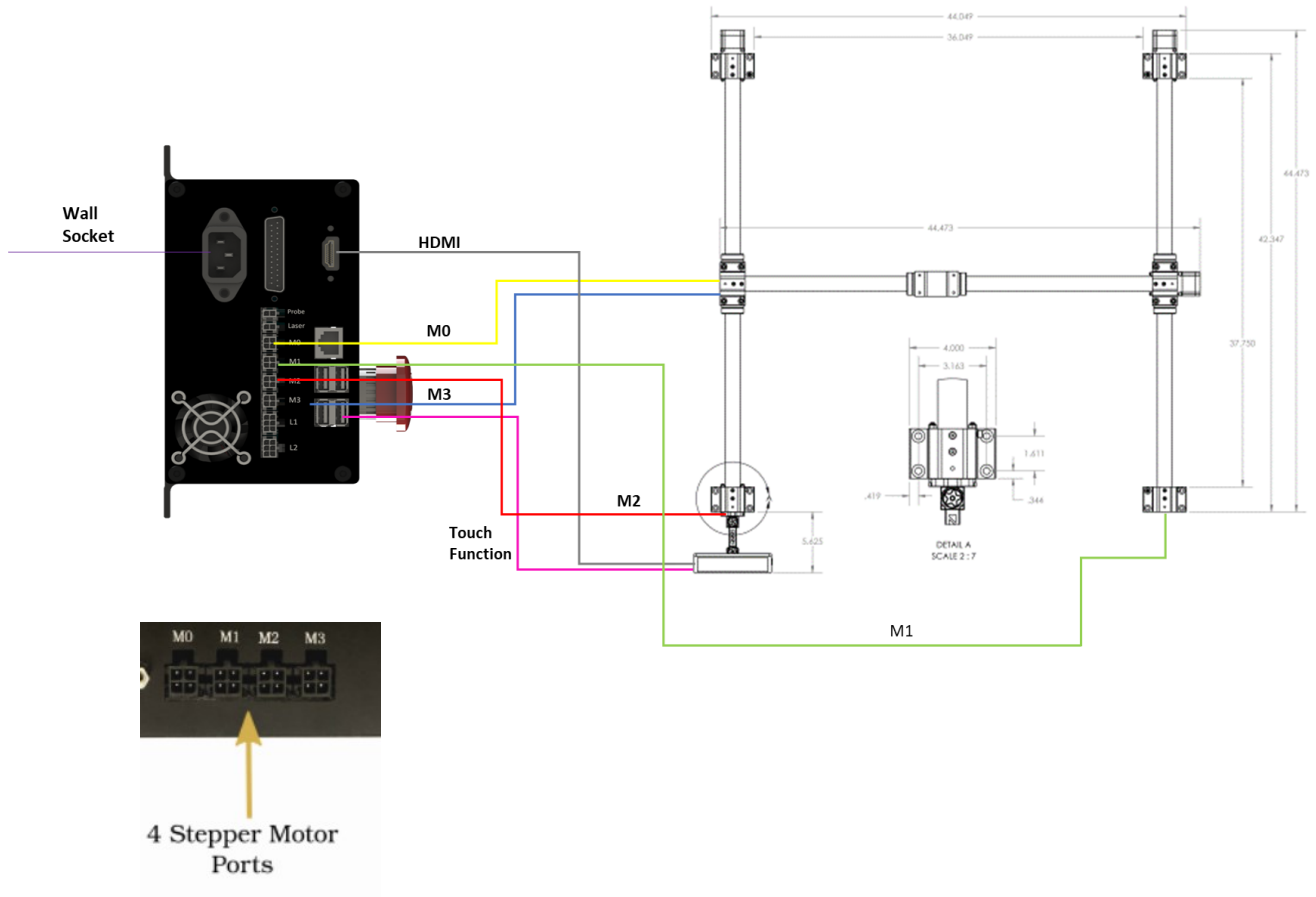

Breakout Board Adapter:

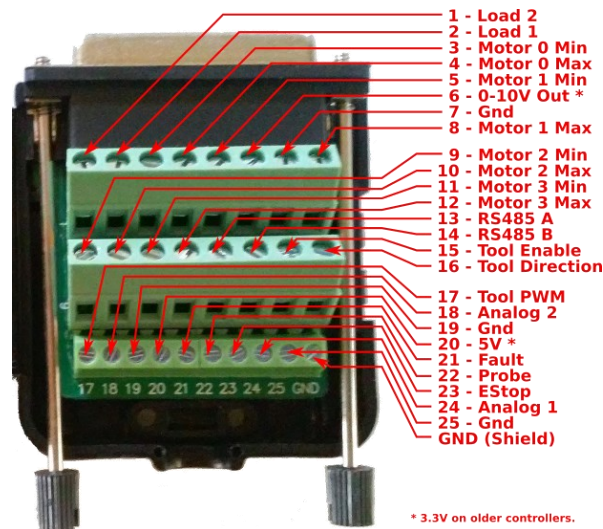

# Connecting the Touch Display

When connecting a touchscreen to the Onefinity controller there are a few key items to make it work correctly:

**Step 1: POWER:** Every screen must be connected to external (wall) power to operate correctly. Skipping this step is the most common mistake users make. On the 7 and 8" screens, the 12v wall power adapter must be connected to the 12v in (red arrow) port. On the 10", there is no 12v power input, instead, a USB C port labeled with a lightning bolt is used (red arrow). This cable must be plugged into the supplied 5 volt, 3 amp USB wall power brick to wall power. Without using external power, the screen will flicker during use.

\*\*Important note: Some sized screens have a circular port labeled 'HP' that can be confused as the 12v power in port. The 'HP' port is for headphones. DO NOT plug in the 12v power adapter into this port. Doing so will damage the screen.\*\*

**Step 2: TOUCH:** For the screen to get its 'touch' ability, the USB C cable plugs into the USB C port on the side of the 7,8, and 10" screens (the usb c port not labeled with the lightning bolt in the case of the 10" screen) (red arrow) and the other end must be connected to any one of the 4 usb ports on the back of the Onefinity controller. This connection enables the 'touch' ability.

**Step 3: VIDEO SIGNAL:** Finally, the HDMI cord provides the video signal. One end will go to the touch screen port labeled HDMI (Green arrow) and the other into the HDMI port in the back of the Onefinity controller.

**Step 4: SCREEN RESOLUTION:** It is important that the screen is powered on via the screens own power button 5-10 seconds before turning on the Onefinity controller. The controller 'learns' what screen resolution to output to from the screen but to do so, the screen must be on for the controller to get that information. Failure to turn on the screen first may lead to black bars across the top and bottom of the display (wrong resolution output) and touch being an inch or so off from expected input. To fix, simply reboot the controller with the screen on first.

RED = Power

Blue = USB Touch

Green = Display (HDMI)

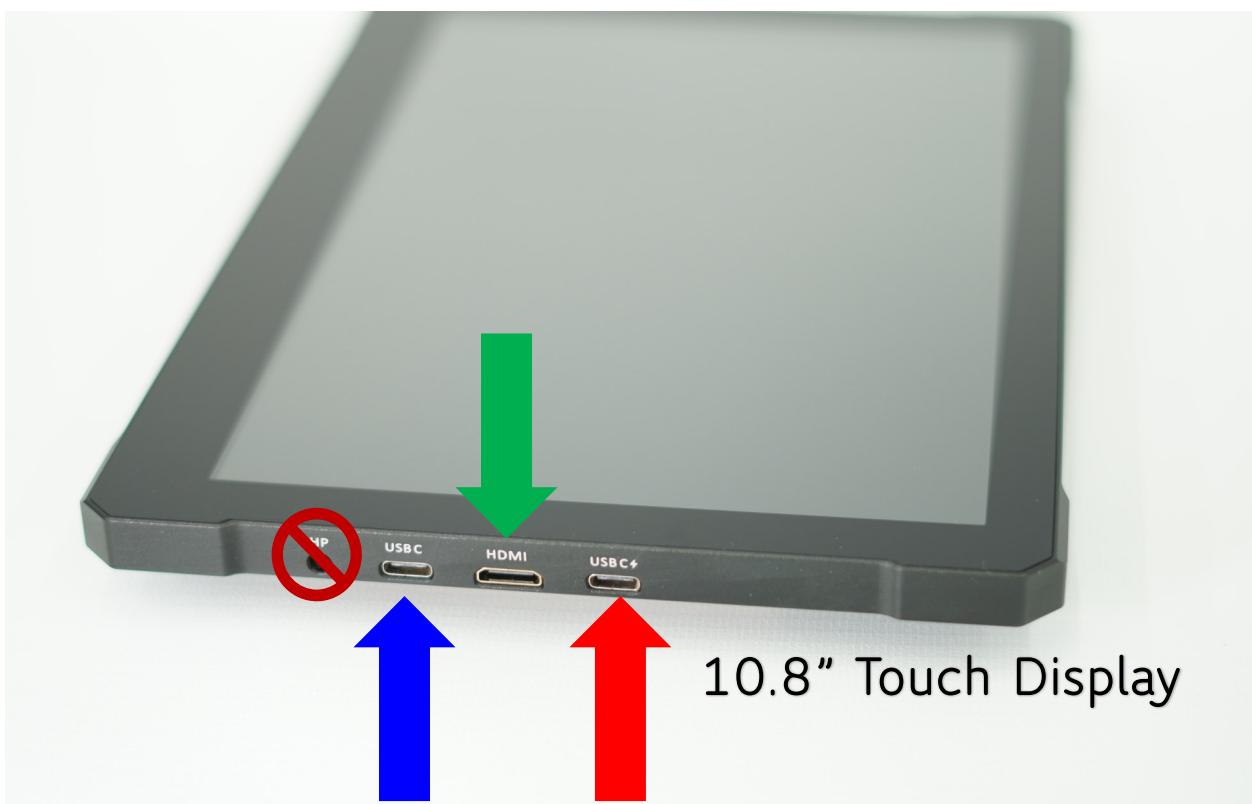
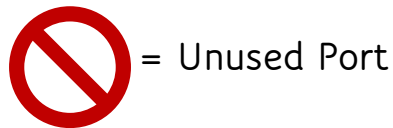

# Connecting the Touch Display

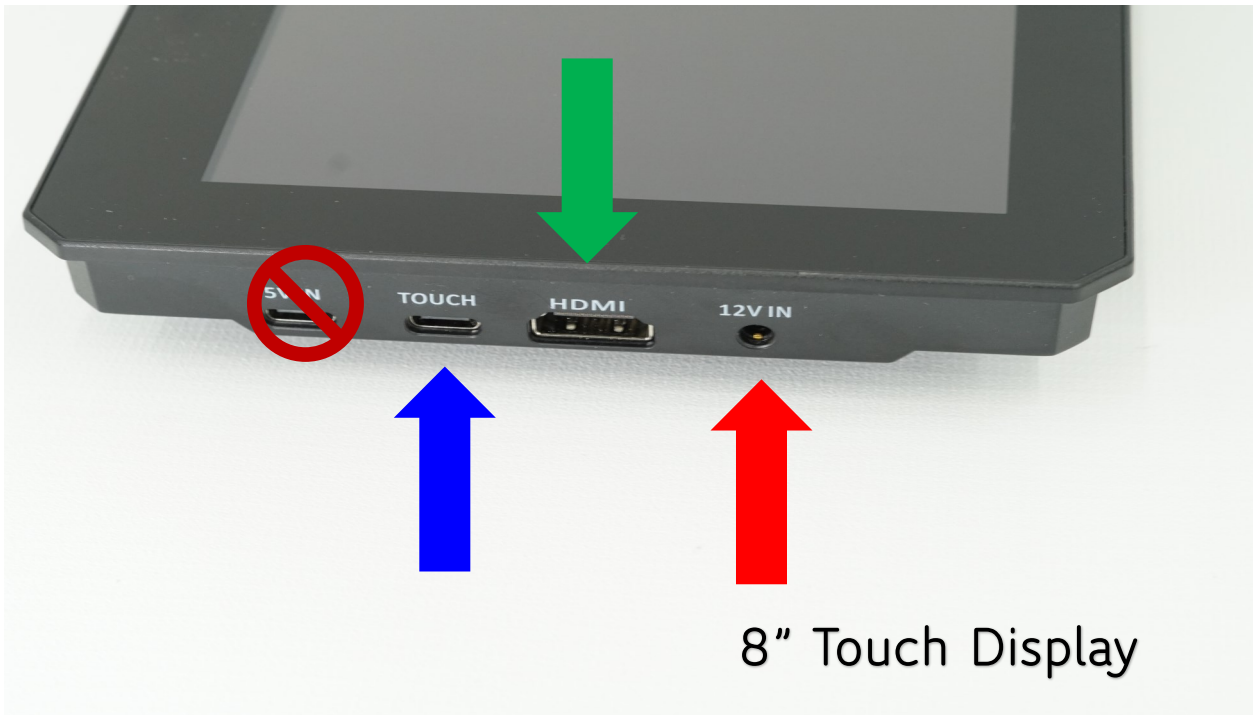

RED = Power

Blue = USB Touch

Green = Display (HDMI)

 = Unused Port

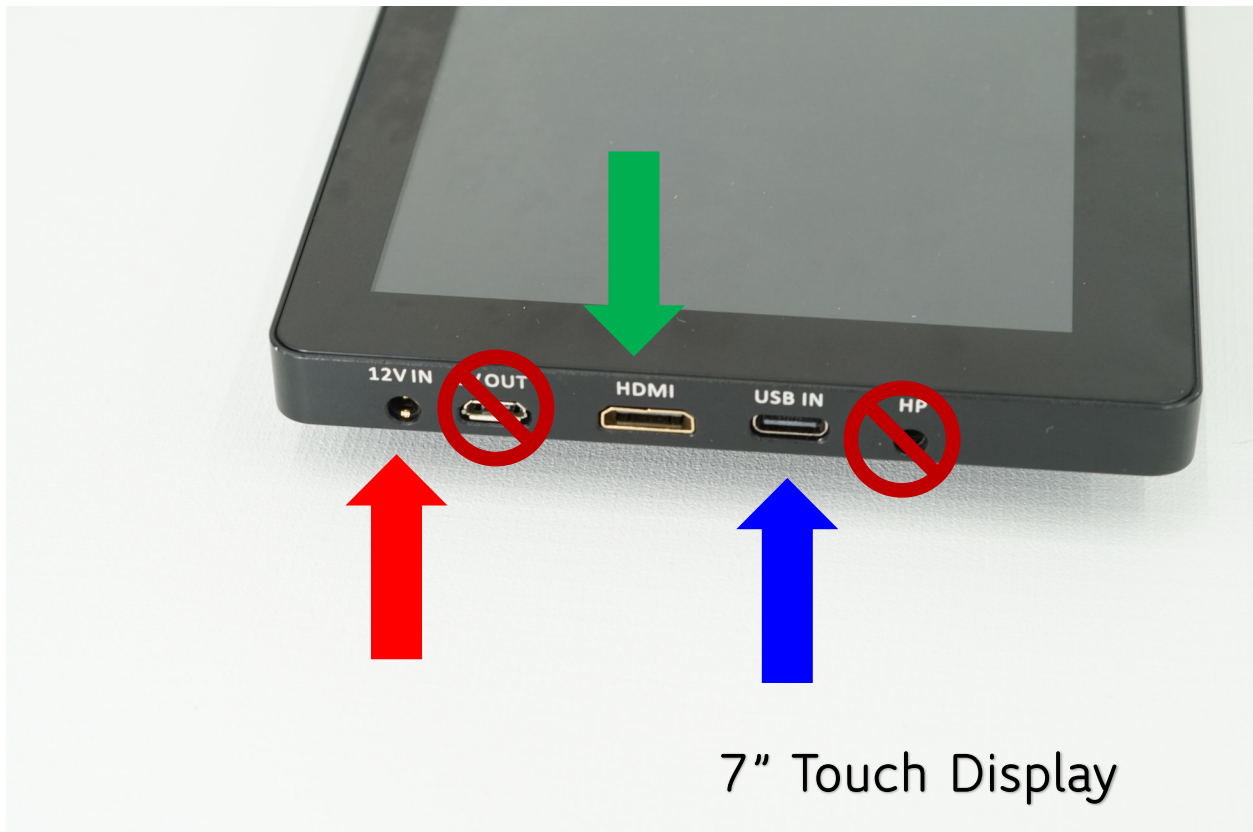

# Assembly Instructions

**Step 12:** It's now time to power up your machine. Start by simultaneously twisting and pulling out on the Emergency Stop Button clockwise to release it to the "ON" position (Green Arrow). Next flip the switch to the ON position (Purple Arrow). Wait a few seconds for the Controller to start powering up then turn on the Touch Display by pushing the ON button



**Step 13:** We will now jog the Y-Axis so we can finish fastening the Y-Rails to the table. First ensure you are using metric units (Blue Arrow). If metric is not selected, tap the drop down arrow and select metric. Next, hit to 100 button (Green Arrow). This sets the Jogging distance to 100mm.



Axis	Position	Absolute	Offset	State	Toolpath
X		0mm	0mm	0mm <input checked="" type="checkbox"/> HOMED <input checked="" type="checkbox"/> OK	<input checked="" type="checkbox"/>
Y		0mm	0mm	0mm <input checked="" type="checkbox"/> HOMED <input checked="" type="checkbox"/> OK	<input checked="" type="checkbox"/>
Z		0mm	0mm	0mm <input checked="" type="checkbox"/> HOMED <input checked="" type="checkbox"/> OVER	<input checked="" type="checkbox"/>

State	READY	Velocity	0 m/min	Remaining	
Message		Feed	100 mm/min	ETA	
Units	METRIC	Speed	0 RPM	Line	7
Tool	0	Loads	1: Off 2: Off	Progress	0.00%

# Assembly Instructions

**Step 14:** Now Jog the Y-Axis until the X-Rail is all the way to the back of the machine. Do this by tapping the Y+ jog button (Red Arrow). Tap the Y+ button 8 times. Once you have finished jogging, your Y position should read 800mm (Yellow Arrow)

Camera Offline

Axis	Position	Absolute	Offset	State	Toolpath		
X		0mm	0mm	0mm ✓ HOMED ✓ OK		⚙️	📍 🏠
Y	800mm	800mm	0mm ✓ HOMED ✓ OK			⚙️	📍 🏠
Z	0mm	0mm	0mm ✓ HOMED	! OVER		⚙️	📍 🏠

State	READY	Velocity	0 m/min	Remaining	
Message		Feed	8,000 mm/min	ETA	
Units	METRIC ▾	Speed	0 RPM	Line	0
Tool	0	Loads	1:Off 2:Off	Progress	0.00%

Auto MDI Messages Indicators

▶ ■

**Step 15:** After jogging, your machine should look like the picture below.



# Assembly Instructions

**Step 16:** After moving the X-Axis all the way to the back, fasten the back of the Y-Rails to your table using only one (1) Y-Rail Mounting Screw per side (Red Arrow).

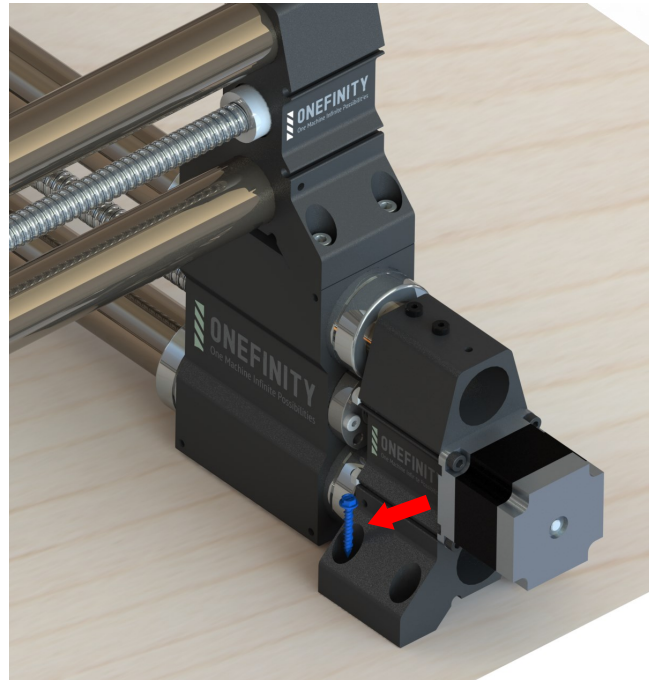
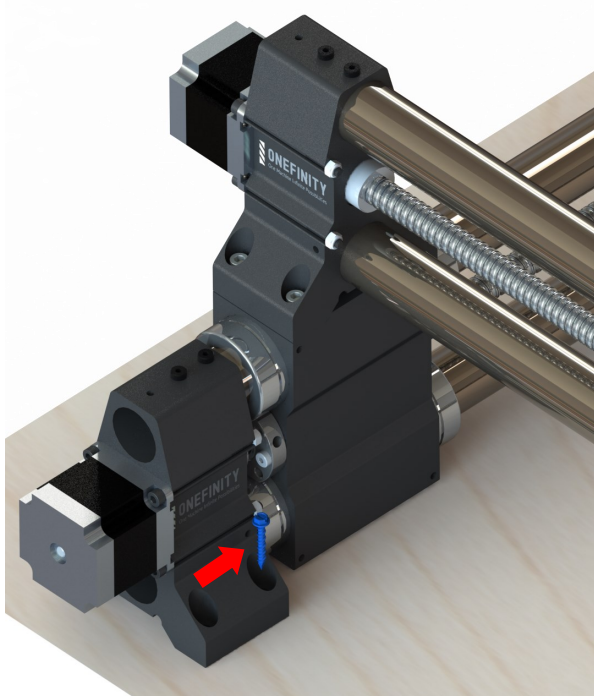

**Step 17:** We will now jog the Y-Axis to bring the X-Rail back to the front of the machine. Tap the Y- button (Green Arrow) 8 times. When finished the Y position should read 0mm (Blue Arrow)

**ONEFINITY**  
One Machine Infinite Possibilities  
CNC Controller v1.0.9 ✓

Camera Offline

Axis	Position	Absolute	Offset	State	Toolpath		
X		0 mm	0 mm	0 mm ✓ HOMED ✓ OK	✓ OK	⚙️	📍
Y		0 mm	0 mm	0 mm ✓ HOMED ✓ OK	✓ OK	⚙️	📍
Z		0 mm	0 mm	0 mm ✓ HOMED	! OVER	⚙️	📍

State	READY	Velocity	0 m/min	Remaining	
Message		Feed	100 mm/min	ETA	
Units	METRIC ▾	Speed	0 RPM	Line	7
Tool	0	Loads	1:Off 2:Off	Progress	0.00%

  

Auto
MDI
Messages
Indicators

GCode view...

# Assembly Instructions

**Step 18:** With the X-Rail all the way to the front again, finish fastening the Y-Rails to the table using another three (3) Y-Rail Mounting screws per side (Green Arrow).

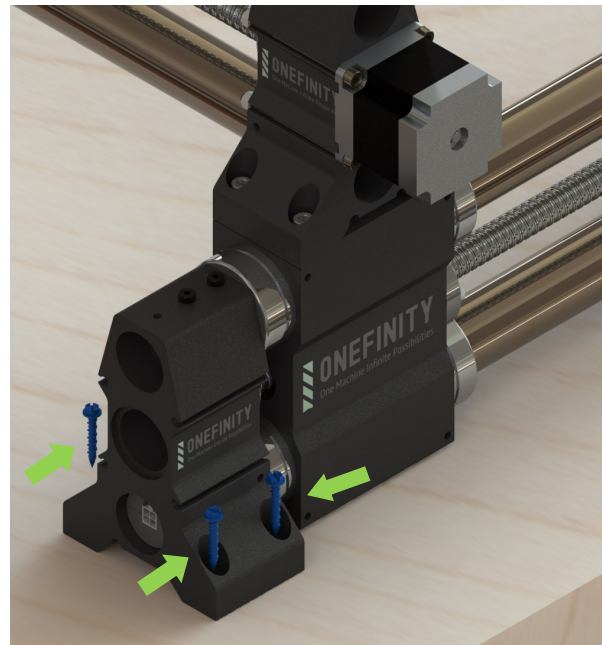
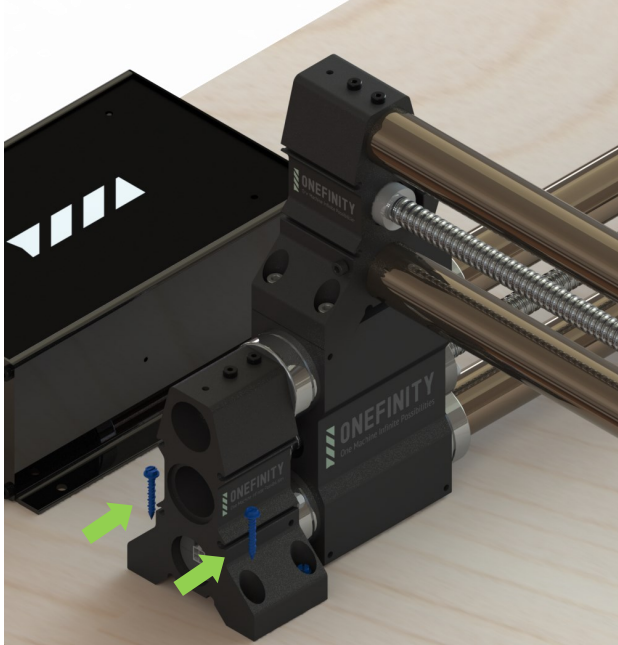

**Step 19:** Repeat steps 14 and 15 to jog the Y-Axis until the X-Rail is to the back of the machine again. Finish fastening the Y-Rails to the table using the remaining three (3) Y-Rail Mounting Screws per side (Green Arrows).

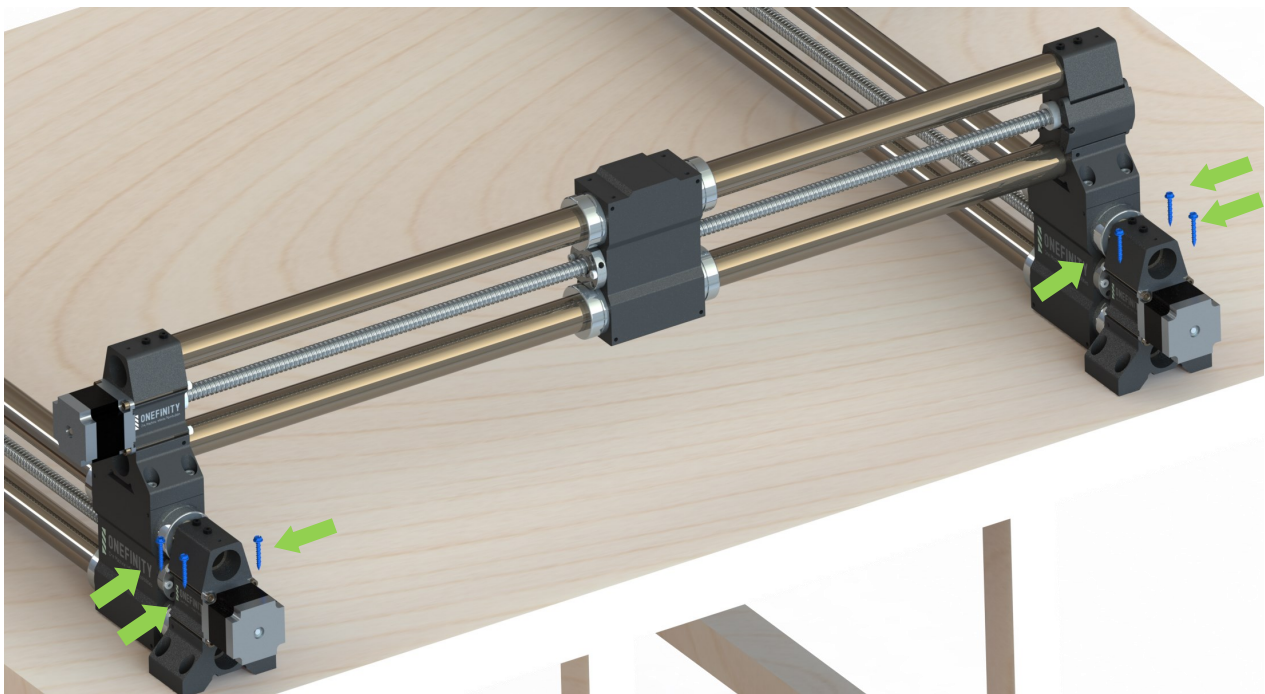

# Assembly Instructions

**Step 20:** Attach the Z-Slider to the X-Axis Gantry Block using the four (4) Z-Slider Mounting Screws. Do not tighten them all the way just yet, you'll do that in the next step. To gain access to the mounting holes you may need to manually turn the ball screw to raise and/or lower the spindle mount. **Note:** In the event you have the Stiffy attached, ensure you do not use the holes in the Stiffy Block to attach the Z-20 Slider.

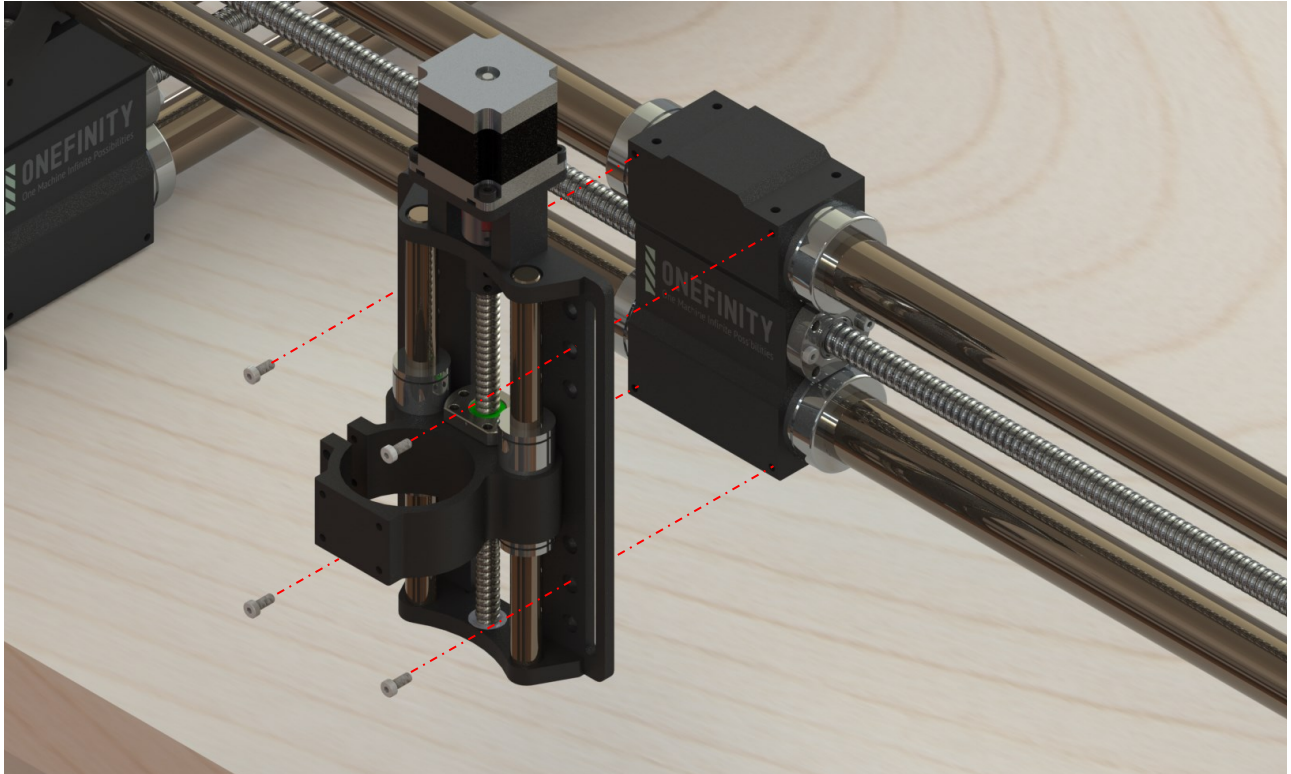

**Step 21:** Square the Z-Slider to your table then tighten the Z-Slider Mounting Screws, making sure to avoid over-torquing them and stripping the threads of the holes. Next, plug the Z-Sliders stepper motor into the darg chain cable. **Congratulations, you have finished assembling your new Onefinity CNC Machine!**

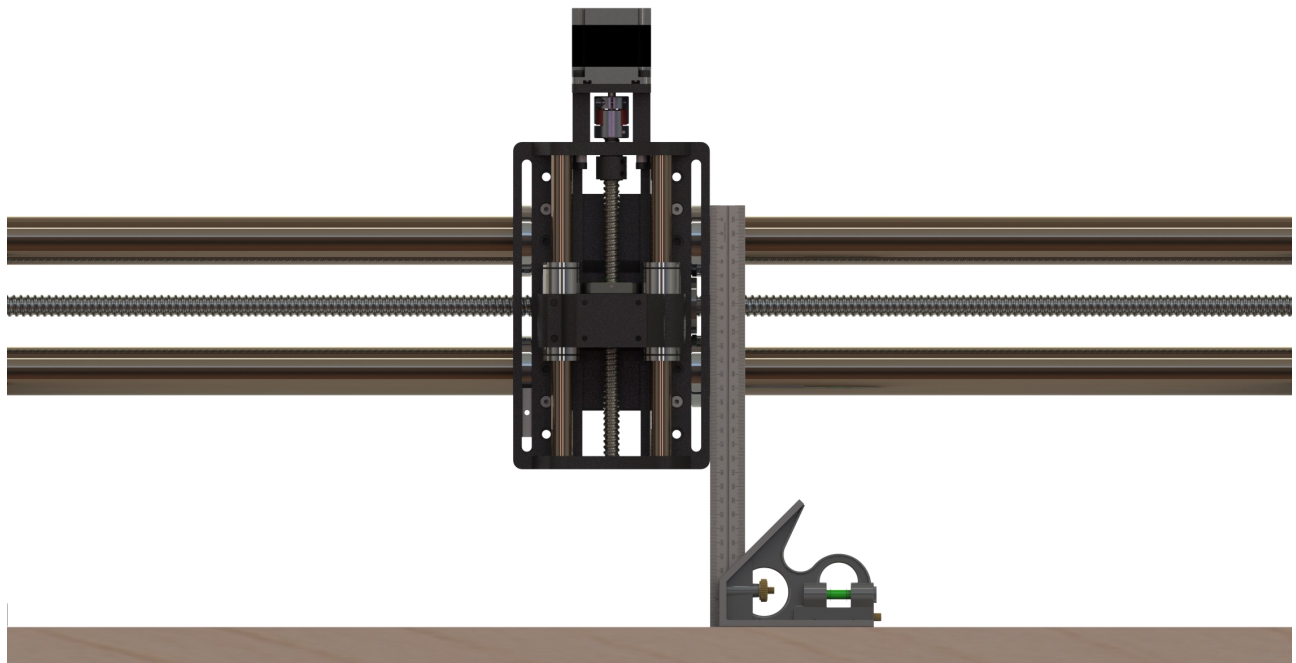



# Spindle/Router Installation

**Step 1:** Manually lower the Spindle Mount until it's roughly 1/4" from bottoming out. Do this by rotating the Stepper Motor Coupler (Green Arrow). Insert the Router (Blue Arrow) into the Spindle Mount (Red Arrow)

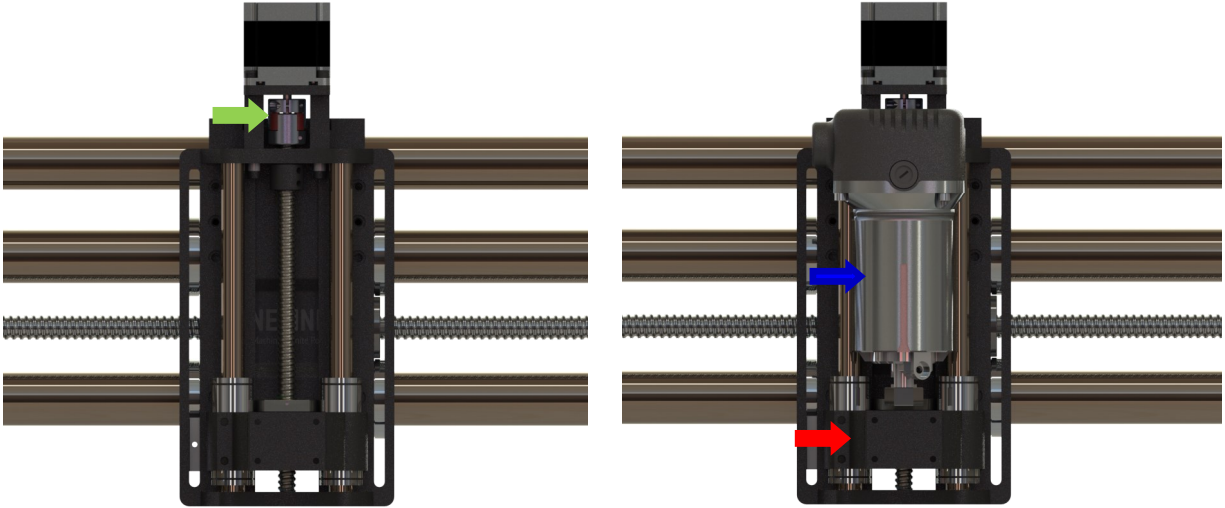

**Step 2:** Slide the Router all the way down in the Spindle Mount. Tighten the Spindle Mount Screws (Green Arrows)

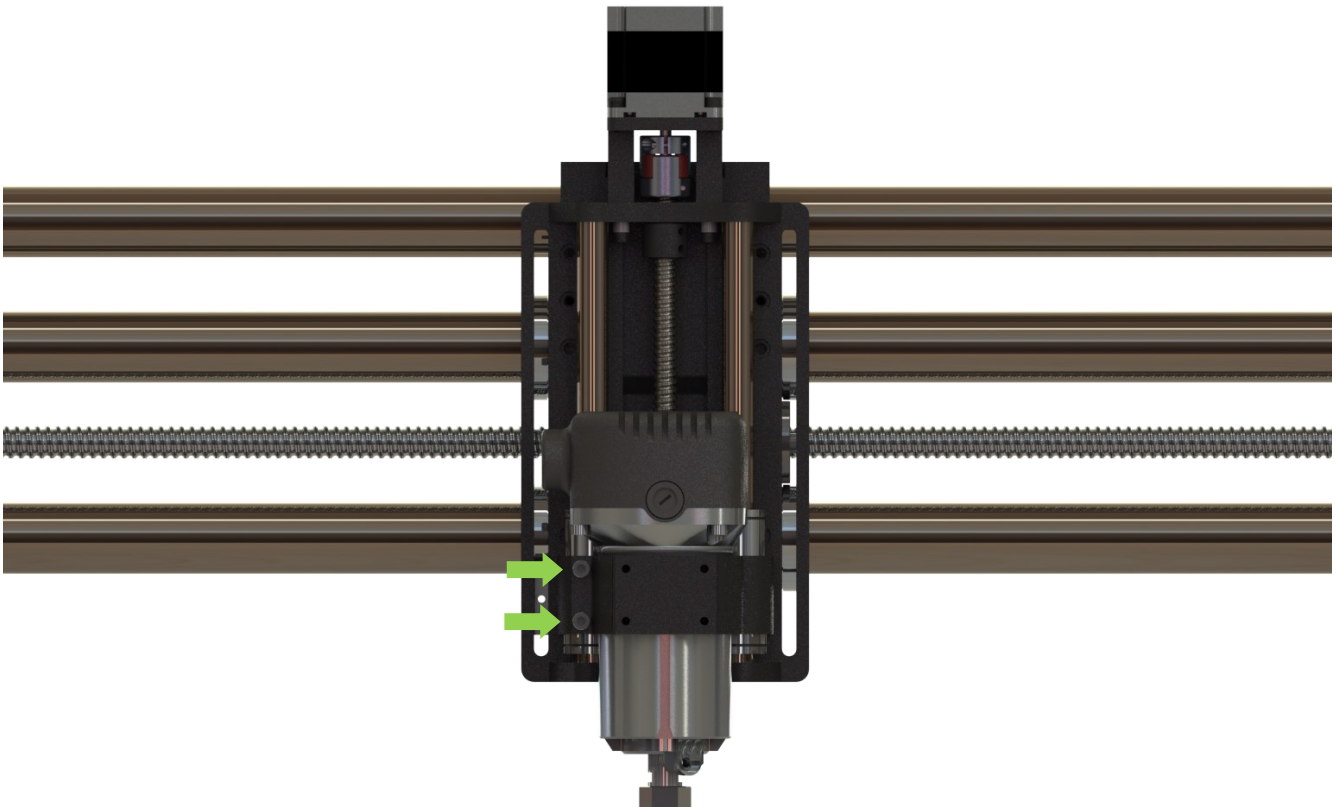

# Wasteboard

A wasteboard is a disposable work surface that will be mounted atop your Onefinity's permanent table. Having a wasteboard is an important part of a CNC and makes using the Onefinity more enjoyable as leveling and workholding becomes easier. The wasteboard is typically MDF and protects the table from damage as well as being an expendable surface. From time to time your wasteboard will need to be surfaced. That means using a spoilboard cutter to clean up any gouges or cuts and make the board flat and parallel to X and Y axis travel. The unique design of the Onefinity allows you to create/use any style Wasteboard you desire.

**Note:** The minimum recommended wasteboard thickness is  $3/4"$ . This allows you to achieve maximum Z-Travel while still having a thick enough surface to attach/clamp your work piece. This thickness will also give you the opportunity to perform several surfacing operations before needing to be replaced.



Model displayed with optional Quick Change Wasteboard (QCW) and Rolling, Folding Stand, available for purchase on our website,

**Note:** For maximum stiffness it is recommended that you build up your wasteboard to a thickness of  $2-1/2"$  -  $3"$ . This will still give you approximately  $3"$  of gantry clearance while reducing the moment force on the Router, Z-Slider and X-Rail parts. When building up your wasteboard to this thickness please ensure you use the Z-Sliders top mounting holes.

# Maintenance

To ensure your Onefinity CNC machine lasts for many years it is important that regular maintenance be performed. For step-by-step instructional videos please visit our Youtube page at: <https://www.youtube.com/onefinitycnc>. **Note:** It is highly recommended that you view our maintenance video prior to performing maintenance on your Onefinity CNC.

**Note:** Before performing maintenance work on your Onefinity CNC machine please ensure that the Router/Spindle **and the mains are disconnected**. All maintenance works must only be performed by someone with knowledge and experience with the Onefinity CNC. Improper maintenance may result in damage to your machine and void your warranty.

## After every carve/project:

Vacuum up all dust and chips. Maintenance of rails should be performed every 50-100 use hours depending on material cut. If the machine is not moving or cutting correctly, maintenance should be performed.

## After every 2-3 hours of operation:

Vacuum up all dust and chips. Use compressed air to blow off dust and debris from the Rails and Ball screws.

## Every 1-4 weeks (Duration will depend on use, heavily used machines should perform this maintenance step regularly):

Apply 3 in one oil into the oil ports of the Ball Screws (Green Arrows). Jog the machine to it's X,Y and Z limits while applying oil to the oil ports in a few different locations. Wipe off any excess oil using a lint free cloth. Note: Cover your waste board with cloths or paper towels as the oil may drip. For more info on maintenance, check out this [Forum Listing](#)

**Please note:** All parts of the machine and controller can be purchased individually as spare parts. Replaceable parts are the motor wires, motor couplers, ball nut and ball screw, and bolt hardware.

Please contact us directly at [info@onefinitycnc.com](mailto:info@onefinitycnc.com) or call us a 1 888 717 4242 to get replacement parts. Please keep your machine data at hand when ordering spare parts.

Required tools to repair or replace items would be metric 1, 1.5, 2, 2.5, 3, 3.5, 4, 4.5, and 5 mm Allen keys, adjustable wrench, screwdriver and power drill, and a microfiber cloth.



# Maintenance

Possible risks are repairs that fail leading to a machine that does not operate correctly. Improper repairs could lead to damaged parts including, broken wiring, stripped bolt hardware, or damaged ball nut and ball screws. You must have a basic understanding of how to use power tools. Repair videos are online via our YouTube Channel. Power must be disconnected before servicing the machine.

All maintenance works must only be performed by someone with knowledge and experience with the Onefinity CNC. Improper maintenance may result in damage to your machine and void your warranty.

## **Transporting the Onefinity CNC:**

When transporting the Onefinity, it is important to do so in pieces. It is best to move each axis rail one at a time due to weight. It's best practice to use the original shipping box and its foam to transport the machine to another location.

When storing the Onefinity, you must do so in a controlled environment. Humidity can cause rust to occur. The lcd screen can be affected by extreme cold. Rapid changes in temperature can also cause condensation buildup that can lead to rust and/or damage to the electronic components of the machine. It's best to store the machine between 40-100 Degrees F, preferably in a climate controlled environment when possible. Ensure storage of electronics to be in a moisture free and dust free environment.

# Loading a Program

There are multiple ways to load a program into your Onewfinity CNC controller. One is via WIFI and the other is via USB. To learn how to connect your Onewfinity to your WIFI network please visit the <https://forum.onewfinitycnc.com/t/connecting-the-onewfinity-cnc-to-a-network/1032>. To load a file via USB please follow the steps below.

[View our in depth video here](https://forum.onewfinitycnc.com/t/loading-a-program/711): <https://forum.onewfinitycnc.com/t/loading-a-program/711>

The controller is the only programmable part of the Onewfinity. The software manual can be found here: <https://forum.onewfinitycnc.com/t/onewfinity-controller-software-manual/6805>

Step 1: Load your program onto the USB drive you plan on using.

Step 2. Plug your USB stick into one of the USB slots in the back of the controller. (Blue Arrow)

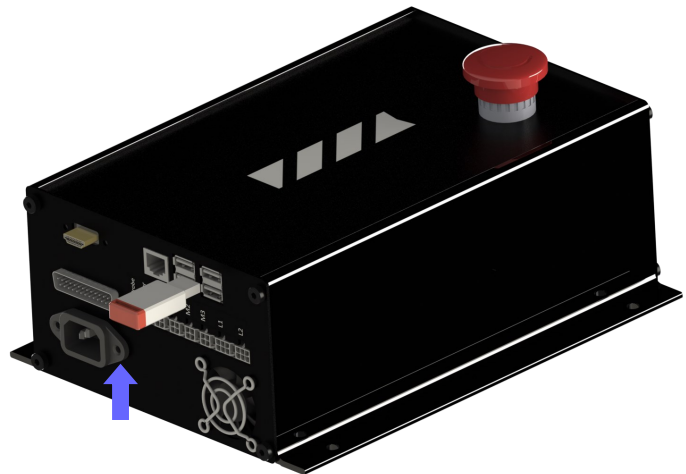

Step 3. Press the File button (Red Arrow) to open the file explorer. **Note:** it is located below the Probing buttons on the main page. You will need to scroll down to find it.

ONEFINITY  
One Machine Infinite Possibilities  
CNC Controller v1.0.9

Camera Offline



Axis	Position	Absolute	Offset	State	Toolpath			
X		0 mm	0 mm	0 mm ✓ HOMED ✓ OK	✓ OK	⚙️	📍	🏠
Y		0 mm	0 mm	0 mm ✓ HOMED ✓ OK	✓ OK	⚙️	📍	🏠
Z		0 mm	0 mm	0 mm ✓ HOMED	! OVER	⚙️	📍	🏠

State	READY	Velocity	0 m/min	Remaining	
Message		Feed	100 mm/min	ETA	
Units	METRIC	Speed	0 RPM	Line	7
Tool	0	Loads	1.Off 2.Off	Progress	0.00%

Auto MDI Messages Indicators

Auto Stop File Download Delete

⚙️ 📏 📐 📏 📏 📏

GCode view...

# Loading a Program

Step 4. Once the files explorer is open, click on the file you would like to load. The selected file will highlight in blue (Yellow Arrow). Once you have selected the file you would like to run click Open (Green Arrow).

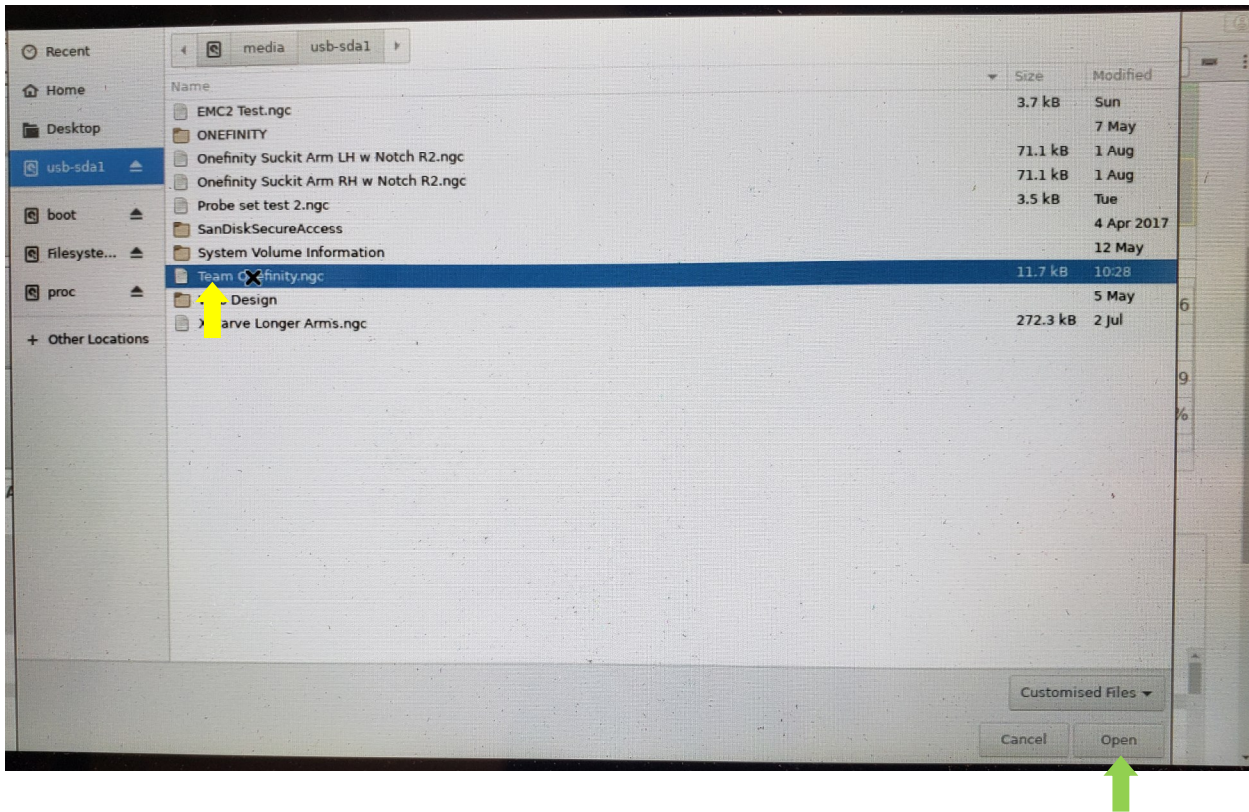

Step 5. Once the file is loaded click the play button (Pink Arrow) to start your program.

The screenshot shows the ONEFINITY CNC Controller v1.0.9 software interface. The top left has the ONEFINITY logo and 'CNC Controller v1.0.9'. The top right shows 'Camera Offline' and an emergency stop button. The main interface is divided into several sections:

- Control Panel:** A grid of directional buttons (Y+, X-, Y-, Z+, X+, Z-, Y-, Z-) and speed buttons (0.1, 1.0, 10, 100). Below this are 'Probe XYZ' and 'Probe Z' buttons.
- Axis Status Table:** A table showing the position and state of the X, Y, and Z axes.
- Machine Status Table:** A table showing machine parameters like State, Velocity, Feed, Speed, and Progress.
- Control Buttons:** A row of buttons including 'Auto', 'MDI', 'Messages', 'Indicators', and a 'Team Onefinity.ngc' dropdown menu. A pink arrow points to the play button.
- Program Editor:** A text area at the bottom showing G-code for a program named 'Team Onefinity.ngc'.

Axis	Position	Absolute	Offset	State	Toolpath	Home	Reset
X		0 mm	0 mm	0 mm ✓ HOMED ✓ OK	✓ OK	⚙️	🏠
Y		0 mm	0 mm	0 mm ✓ HOMED ✓ OK	✓ OK	⚙️	🏠
Z		0 mm	0 mm	0 mm ✓ HOMED ⚠️ OVER	⚠️ OVER	⚙️	🏠

State	READY	Velocity	0 m/min	Remaining	2:08
Message		Feed	100 mm/min	ETA	
Units	METRIC	Speed	0 RPM	Line	7 of 659
Tool	0	Loads	1: Off 2: Off	Progress	0.00%

```

%
$
G21 G40 G49 M6 T1
G17
M7
G0Z20.320
G0X0.000Y0.000S16000M3
G0X26.732Y12.863Z5.080
G1Z-3.175F1270.0
G1X21.606Y17.989F2540.0
G1Y12.042

```

# Adjusting Stall Homing

Your Onefinity comes with the revolutionary Stall Homing feature. This feature allows you to home your Onefinity without the use of delicate, easily broken switches. It also means that you will no longer have to deal with the hassle of wiring. The stall homing works by monitoring the current and voltage of the stepper motors. Once the set current and voltage is met, the axis will be homed. Because each machine and their motors are not exactly the same due to tolerances, we have given the ability to adjust the settings if you find the stall homing is not working properly.

View our in depth video here: <https://forum.onefinitycnc.com/t/how-to-adjust-stall-homing-video/8529>

Step 1: Click on the fly-out menu button (Yellow Arrow)

Step 2: Click on the Motor (Axis) that you would like to adjust.

Motor 0 = X-Axis

Motor 1= Y-Axis

Motor 2=Y-Axis (Slave)

Motor 3= Z-Axis

Step 3. Start by first raising (for rails stopping short), or lowering (for rails that grind against the rail end) the "stall-current" by 0.1 and trying to home the axis again

The screenshot shows the Oonefinity control interface. On the left is a vertical menu with categories: CONTROL, SETTINGS, MOTORS, TOOL, I/O, ADMIN, CHEAT SHEET, and HELP. A yellow arrow points to the menu icon (three horizontal lines) at the top of the menu. A blue arrow points to 'Motor 0' in the MOTORS section. The main area displays the 'Limits' and 'Homing' settings. The 'Limits' section includes: min-soft-limit (0 mm), max-soft-limit (816 mm), min-switch (disabled), and max-switch (disabled). The 'Homing' section includes: homing-mode (stall-min), stall-microstep (8 per full step, 2.8k µstep/sec), search-velocity (1.688 m/min, 106 RPM), stall-volts (2 v), stall-sample-time (200 µsec), stall-current (1 amps), and zero-backoff (1.5 mm). Colored arrows point to specific settings: a purple arrow to 'stall-microstep', a green arrow to 'stall-volts', and a red arrow to 'stall-current'.

Step 4: Continue raising or lowering the "stall-current" by 0.1 until you are satisfied or until you get to 0.1 amps.

# Reset Button (Soft E-Stop)

The motion control software that comes with your Onefinity is equipped with a Reset Button/ Soft E-Stop (Blue Arrow). This Reset Button is very useful in certain circumstances and stops motion of your machine when hit. Clicking the Reset Button (Soft E-Stop) disables all motors and causes all position and homing information to be lost. The yellow ring turns orange when the "emergency stop" is clicked the first time. Clicking it again attempts to clear the "emergency stop". If the "emergency stop" clears, the outer ring changes back to yellow.

Instances when you may want to use the Reset Button (Soft E-Stop):

1. While homing, you notice it is not working as expected, hit the Rest Button (Soft E-Stop), start the homing sequence again.
2. While probing, the magnet was not attached or not attached properly to the router collet, or you get an error while probing, hit the Rest Button (Soft E-Stop), ensure the probe is connected properly and start the probing sequence again.
3. You get an error while trying to run a program.
4. The software becomes unresponsive.
5. You want to reset what you are doing and start over.

This is just a small sample list, there are other instances when Rest Button (Soft E-Stop) will be useful.

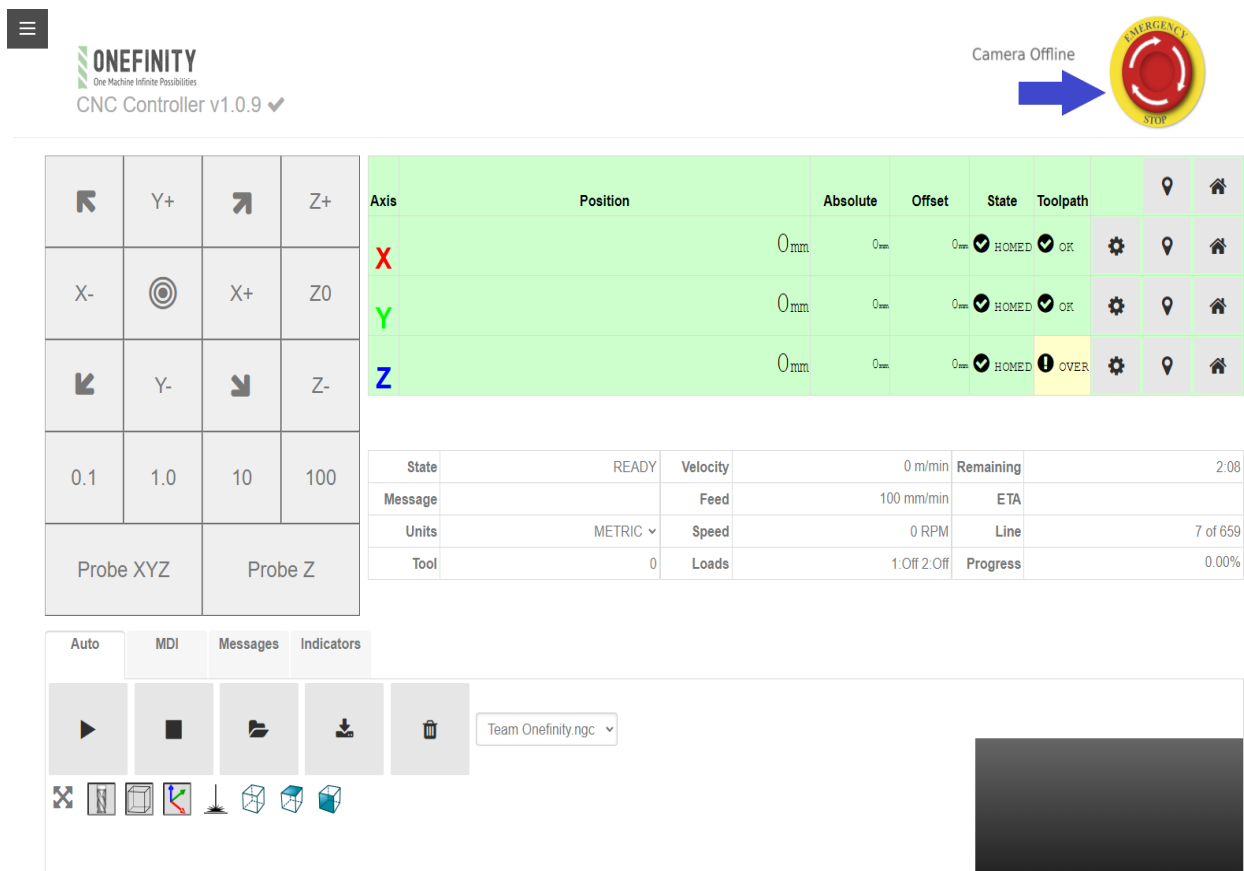

The screenshot displays the Onefinity CNC Controller v1.0.9 interface. At the top left, the Onefinity logo and version are shown. On the right, a "Camera Offline" notification is present next to a red emergency stop button with a blue arrow pointing to it. The main interface features a control panel with directional keys (Y+, Z+, X-, X+, Y-, Z-), feed rates (0.1, 1.0, 10, 100), and probe controls (Probe XYZ, Probe Z). A central table displays machine status for X, Y, and Z axes, showing they are homed and in an "OVER" state. Below this, a detailed status table provides information on State (READY), Velocity (0 m/min), Remaining time (2:08), Message, Feed (100 mm/min), ETA, Units (METRIC), Speed (0 RPM), Line (7 of 659), Tool (0), Loads (1:Off 2:Off), and Progress (0.00%). The bottom of the interface includes a control bar with buttons for Auto, MDI, Messages, and Indicators, along with a file selection dropdown set to "Team Onefinity.ngc" and a set of tool icons.

Axis	Position	Absolute	Offset	State	Toolpath			
X		0mm	0mm	0mm ✓ HOMED ✓ OK	✓ OK	⚙️	📍	🏠
Y		0mm	0mm	0mm ✓ HOMED ✓ OK	✓ OK	⚙️	📍	🏠
Z		0mm	0mm	0mm ✓ HOMED	! OVER	⚙️	📍	🏠

State	READY	Velocity	0 m/min	Remaining	2:08
Message		Feed	100 mm/min	ETA	
Units	METRIC	Speed	0 RPM	Line	7 of 659
Tool	0	Loads	1:Off 2:Off	Progress	0.00%



# Touch Probe Fine Tuning

If you purchased a touch probe from Onefinity it will be preprogrammed. Some users may feel the need to adjust the accuracy due to manufacturing tolerances or providing their own probe. To adjust the settings so your probe works with the Onefinity, please follow the steps below.

View our in depth video here: <https://youtu.be/jsiKYUPfeUM>

Step 1: Click on the fly-out menu button (Yellow Arrow)

Step 2: Click on Settings (Green Arrow)

Step 2. In the Probe dimensions area (Red Arrow), adjust the setting to match the dimensions of your probe.

Step 3. You can also adjust the "seek speed" while probing. To do so, change the values in the "Probe-fast-seek" and "Probe-slow-seek".

The screenshot displays the Oonefinity control interface. On the left is a dark sidebar menu with a 'Save' button at the top and a fly-out menu icon (three horizontal lines) indicated by a yellow arrow. The menu items are: CONTROL, SETTINGS (indicated by a green arrow), MOTORS (indicated by a green arrow), Motor 0, Motor 1, Motor 2, Motor 3, TOOL, I/O, ADMIN (with sub-items General and Network), CHEAT SHEET, and HELP. At the bottom of the sidebar is a blue power button. The main content area is white and contains the following sections:

- Units**: A dropdown menu labeled 'units' is set to 'METRIC'.
- Probing Safety Prompts**: A checkbox labeled 'probing-prompts' is checked.
- Probe Dimensions**: Indicated by a red arrow, this section contains six input fields:
  - probe-diameter: 6.35 mm
  - probe-xdim: 53.975 mm
  - probe-ydim: 53.975 mm
  - probe-zdim: 15.4 mm
  - probe-fast-seek: 75 mm/m
  - probe-slow-seek: 25 mm/m

# Joypad Layout and Controls

The correct model is **ESM-9013** (other model numbers may not move the z axis.)  
You will never need to install any drivers or software to use the joypad.

**Ensure you are in the right mode with two blue lights on the top.**

To use, follow these steps:

1. Insert batteries into the joypad following the diagram below.
2. Insert the USB dongle into any of the 4 USB ports in the back of the Onefinity Control Box.
3. Press the center button on the joypad for a 30-60 seconds, until the LEDs light up blue.
4. Press the center button until you are in the correct mode.

If the left stick controls your x and y axis, but the right stick is not controlling your z axis, your joypad is in the wrong mode. Follow below to change modes.

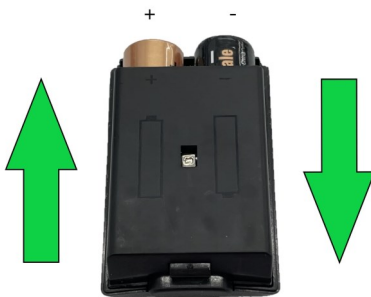

**ONEFINITY**  
JOYSTICK CONTROLS



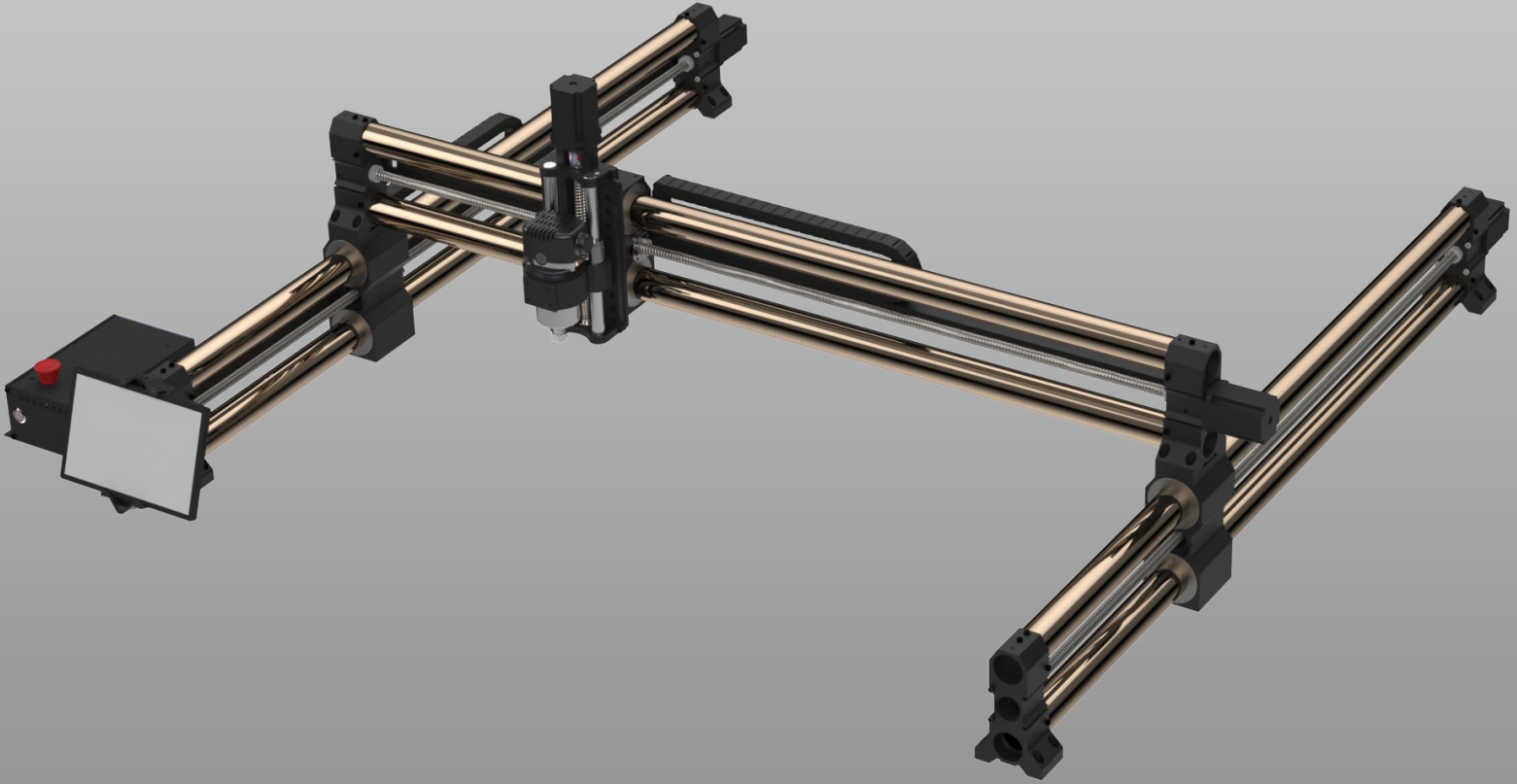

# ONEFINITY 12-MONTH LIMITED WARRANTY

PLEASE SEE REVERSE SIDE FOR DE-  
TAILS

# Limited warranty details

## IMPORTANT! SAVE THE ORIGINAL SHIPPING MATERIALS FOR WARRANTY REPAIR

1. Kirbre Enterprises Inc. ("Kirbre", "us", "we", "our") warrants the Onewfinity CNC machine ("Onewfinity CNC") to be free from defects in workmanship and materials for a period of twelve (12) months from the original shipment date when used in accordance with the Onewfinity CNC [HYPERLNK]Owner's Manual.

Warranty repairs may require you to install a replacement part provided by Kirbre or, at Kirbre's discretion, require you to return the Onewfinity CNC for warranty service. The Onewfinity Limited Warranty is limited to the repair of the Onewfinity CNC with new or refurbished parts for any defect in material or workmanship and when applicable, at our discretion, to the exchange of your warranted Onewfinity CNC for a new or refurbished Onewfinity CNC of equal or greater value.

2. **Verification and Return.** Such repair or replacement is subject to verification of the defect or malfunction and proof of purchase as confirmed by showing the Onewfinity CNC model number on the original dated sales receipt. If we conclude shipping is necessary we will provide you with a shipping label. You are solely responsible for all shipping and handling fees as well as VAT, import duties, any applicable taxes, and other related fees (collectively "Import Costs") you may be required to pay when shipping the Onewfinity CNC to us, and we will not assume any responsibility for any payments relating thereto (including but not limited to brokerage fees, storage fees, etc.). You are solely responsible for any damage to the Onewfinity CNC during shipping, so please ensure packaging of the Onewfinity CNC follows the instructions provided in Section 3, "Returns", of our Shipping and Returns Policy. Any additional costs incurred for transportation or removal of your Onewfinity CNC are not covered by this Limited Warranty. For all valid warranty repairs, Onewfinity will pay for return shipping to you excluding any Import Costs. If your machine does not qualify for warranty repair, then you will be required to pay for all shipping related costs to and from Kirbre including any Import Costs.

3. **WARRANTY LIMITATIONS.** This warranty does not cover repairs for:

- Onewfinity CNC used for commercial purposes or used in any manner for which the product was not intended, such as use in rental or contract trade

- Onewfinity CNC damaged as a result of incorrect or inadequate maintenance or care
- Damages resulting from misuse, abuse, negligence, accidents or shipping damage
- Damages that are the result of normal wear and tear

- Damages incurred during transportation

- Damages incurred during assembly or maintenance

- Damages that are determined to be from repairs made by third parties not authorized by

Without limiting the generality of the foregoing, this warranty will be void and no warranty coverage will be provided if you do any of the following:

- install any firmware in the Onewfinity CNC which is not specifically issued or authorized by Kirbre; make any change or modification to the

- electronics or computer components of the Onewfinity CNC; attach any peripherals or accessories to the electronics or computer components of

- the Onewfinity CNC that have not been specifically issued or authorized by Kirbre; use or attempt to use the Onewfinity CNC and/or its electronics

- or computer components to control or move any device or object not specifically issued or authorized by Kirbre; or if the Onewfinity CNC's serial

- number has been removed or altered.

**4. Obtaining Service.** Technical support is done through email only at support@onefinitycnc.com. To obtain warranty service, first email

Onefinity at support@onefinitycnc.com and include your order number, contact info along with a brief explanation of the issue you are having.

Support will work with you via email to diagnose the issue. This may require you to send one or more pictures and/or videos to help with the diagnostics. If support deems a warranty repair is required, they will issue you an RMA authorization number and provide you with either an electronic shipping label to return your part for repair or send a replacement part that may include a return shipping label, whichever they see fit. If you are using unauthorized and unsupported user modifications (ie: Spindles, Drag Chains, Etc.) support may require you to remove these items and return the machine to factory shipping state to determine if your machine needs warranty work.

Failure to comply with supports requests will void your warranty. Do NOT send any parts back to Onefinity CNC or Kirbre without authorization from support first. Any item returned to Onefinity without an RMA # will be forfeited by the shipper.

**5. ACCEPTANCE OF THE EXCLUSIVE REPAIR AND REPLACEMENT REMEDIES DESCRIBED HEREIN IS A CONDITION OF THE CONTRACT FOR THE PURCHASE OF EVERY ONEFINITY CNC MACHINE. IF YOU DO NOT AGREE TO THIS CONDITION, YOU SHOULD NOT PURCHASE THE PRODUCT. IN NO EVENT SHALL KIRBRE, ITS DIRECTORS, OFFICERS, EMPLOYEES, AGENTS, CONSULTANTS, LICENSORS AND THIRD PARTY SUPPLIERS BE LIABLE FOR ANY INCIDENTAL, SPECIAL, CONSEQUENTIAL OR PUNITIVE DAMAGES, OR FOR ANY COSTS, ATTORNEY FEES, EXPENSES, LOSSES OR DELAYS ALLEGED TO BE AS A CONSEQUENCE OF ANY DAMAGE TO, FAILURE OF, OR DEFECT IN ANY PRODUCT INCLUDING, BUT NOT LIMITED TO, ANY CLAIMS FOR LOSS OF PROFITS. SOME JURISDICTIONS DO NOT ALLOW THE EXCLUSION OR LIMITATION OF INCIDENTAL OR CONSEQUENTIAL DAMAGES, SO THE FOREGOING LIMITATION OR EXCLUSION MAY NOT APPLY TO YOU. THIS WARRANTY IS EXCLUSIVE AND IN LIEU OF ALL OTHER EXPRESS WARRANTIES, WRITTEN OR ORAL. TO THE EXTENT PERMITTED BY LAW, KIRBRE DISCLAIMS ANY IMPLIED WARRANTIES, INCLUDING WITHOUT LIMITATION ANY IMPLIED WARRANTY OF MERCHANTABILITY OR FITNESS FOR A PARTICULAR USE OR PURPOSE; TO THE EXTENT SUCH DISCLAIMER IS NOT PERMITTED BY LAW, SUCH IMPLIED WARRANTIES ARE LIMITED TO THE DURATION OF THE APPLICABLE EXPRESS WARRANTY AS DESCRIBED ABOVE. SOME STATES AND PROVINCES DO NOT ALLOW LIMITATIONS ON HOW LONG AN IMPLIED WARRANTY LASTS, SO THE ABOVE LIMITATION**



**General Disclaimer:**

While Onefinity has made every effort at the time of publication to ensure the accuracy of the information provided herein, product specifications, configurations, system/component/options availability are all subject to change without notice. Product design specifications and colours are subject to change without notice and may vary from those shown. Errors and omissions excepted. Images displayed are for illustration purposes only. The images are intended to help illustrate the product and it's functions and are not indicative of actual relative differences.

[www.onefinitycnc.com](http://www.onefinitycnc.com)

Email: [info@onefinitycnc.com](mailto:info@onefinitycnc.com) or Call: 1 888 717 4242

CE



General Disclaimer:

While Onefinity has made every effort at the time of publication to ensure the accuracy of the information provided herein, product specifications, configurations, system/component/options availability are all subject to change without notice. Product design specifications and colours are subject to change without notice and may vary from those shown. Errors and omissions excepted. Images displayed are for illustration purposes only. The images are intended to help illustrate the product and its functions and are not indicative of actual relative differences.