

**Woodpeckers®**  
**ULTRA-SHEAR**  
WOODTURNING TOOLS

## **PEN MILL-Ci**

 **CAUTION! SHARP EDGES**

### **Pen Mill Assembly**

Align engraved logo on the Pilot-Reamer with set screw in Milling Head. This will align the milled flat section on the Pilot-Reamer shaft directly under the set screw when the Pilot-Reamer is fully inserted.

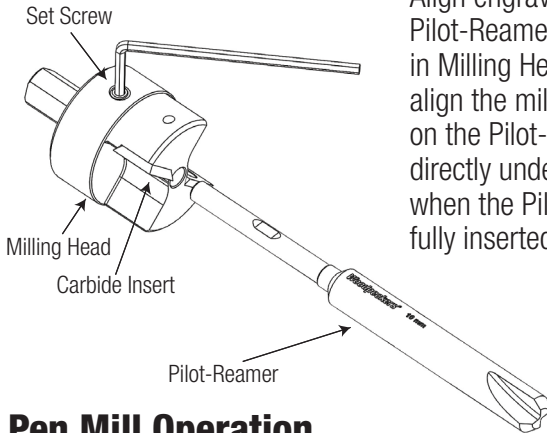

### **Pen Mill Operation**

**Drill Press use only.** Carbide Insert cutters are very sharp and should not be used in a hand held drill. Use speeds below 1000 rpm for best results. Use light downward pressure and let the cutters do the work. Out-of-square ends should be engaged slowly to prevent tear out. Pilot-Reamer will remove glue over-run and burrs.

If you think you're missing anything, email us at [mailroom@woodpeck.com](mailto:mailroom@woodpeck.com). You can also call us at 800-752-0725 from 9:00 a.m. to 5:00 p.m. EST Monday - Friday.

## Pilot-Reamer Sizes Available at *Woodpeck.com*

7mm	25/64"	27/64"	31/64"
"0"	10mm	11mm	12.5mm
3/8"	10.5mm	15/32"	33/64"

To avoid confusion, the Pilot-Reamers are engraved with the diameter of the drill bit used for various pen kits. They are not the diameter engraved on the tool. They are sized to fit inside the brass tube glued into the blank.

Be sure the Carbide Insert is seated squarely in the pocket before securing the screw.

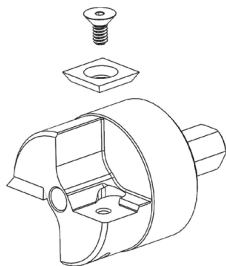

# **Woodpeckers<sup>®</sup>**

PRECISION WOODWORKING TOOLS MADE IN USA  
Woodpeckers, LLC Strongsville, Ohio · **woodpeck.com**  
© 2018 Woodpeckers, LLC

REV110218



**WARNING!** This product can expose you to chemicals, including chromium, which is known to the State of California to cause cancer and birth defects or other reproductive harm. For more information go to [www.P65Warnings.ca.gov](http://www.P65Warnings.ca.gov)