

Woodpeckers[®]

AUTOSCALE[™]

MITER SLED

O W N E R ' S M A N U A L

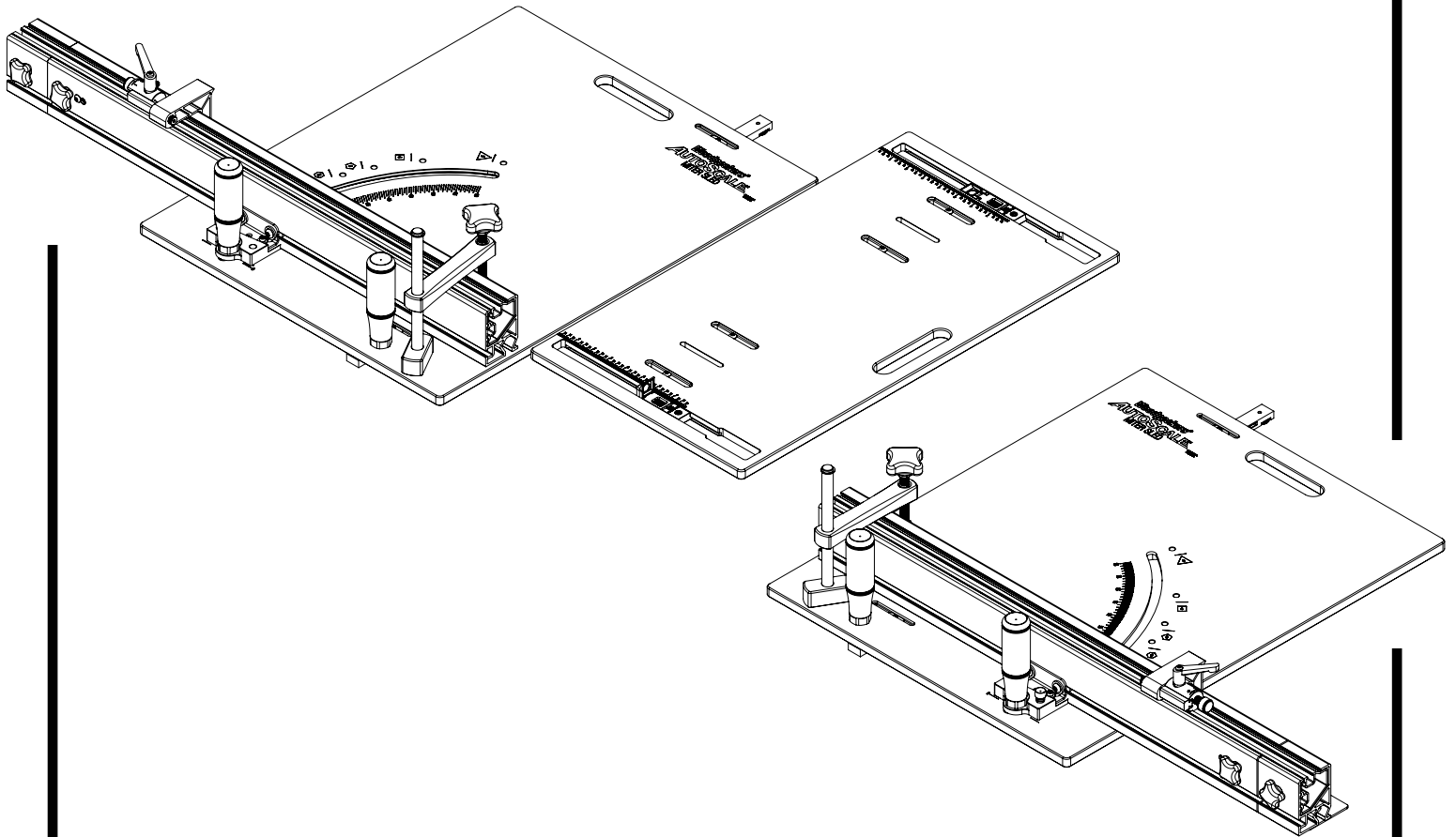

Scan the QR code above
to watch the video
or visit woodpeck.com
under the video tab towards
the bottom of the product page.

If you think you're missing anything, email us at mailroom@woodpeck.com.
You can also call us at 800-752-0725 from 9:00 a.m. to 4:00 p.m. EST Monday - Friday.

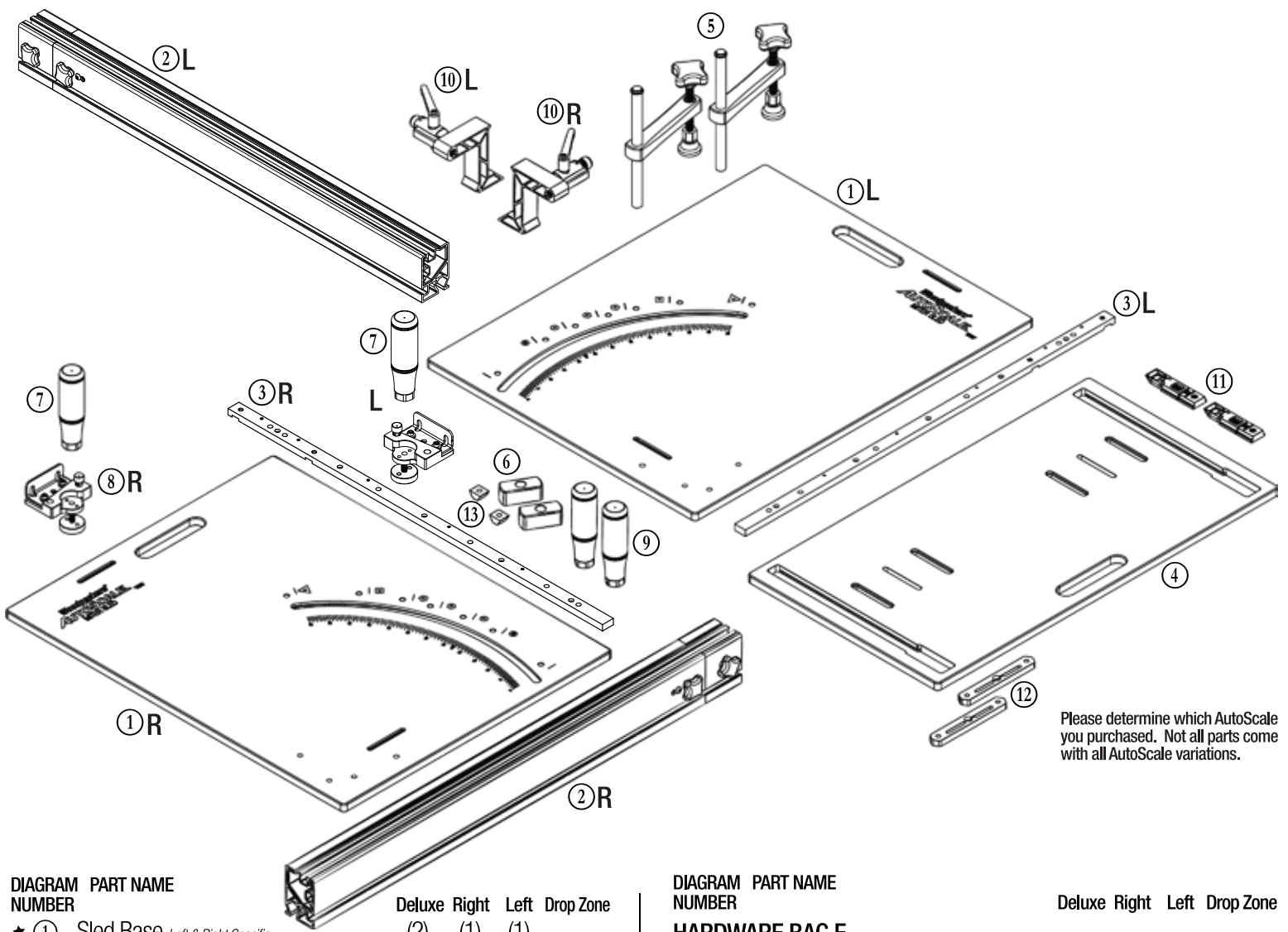

Please determine which AutoScale you purchased. Not all parts come with all AutoScale variations.

DIAGRAM NUMBER	PART NAME	Deluxe	Right	Left	Drop Zone
★ ①	Sled Base <i>Left & Right Specific</i>	(2)	(1)	(1)	--
②	Fence Assembly <i>Left & Right Specific</i> w/2 Multi-Knobs, 50" Fence Extension & Long Part Support	(2)	(1)	(1)	--
★ --	68" Fence Extension <i>Sold Separately</i>	--	--	--	--
③	Miter Bar <i>Left & Right Specific</i>	(2)	(1)	(1)	--
★ ④	Drop Zone Base	(1)	--	--	(1)
HARDWARE BAG A					
⑤	Hold Down Clamp	(2)	(1)	(1)	--
⑥	Hold Down Clamp Base	(2)	(1)	(1)	--
--	Phillips Flat Head Screw 1/4-20x3/4"	(4)	(2)	(2)	--
HARDWARE BAG B					
⑦	Stationary Grip Handle	(2)	(1)	(1)	--
--	Hex Head Screw 1/4-20x3/4"	(2)	(1)	(1)	--
HARDWARE BAG C					
⑧	Calibration w/ Slider Puck Assembly <i>Left & Right Specific</i>	(2)	(1)	(1)	--
--	Shoulder Screw	(4)	(2)	(2)	--
--	Button Head Screw 1/4-20x3/4"	(4)	(2)	(2)	--
--	Washer 1/4"	(4)	(2)	(2)	--
--	Oval Nut, 1/4-20	(4)	(2)	(2)	--
HARDWARE BAG D					
⑨	Pivot Grip Handle	(2)	(1)	(1)	-
HARDWARE BAG E					
★ ⑩	Flip Stop <i>Left & Right Specific</i>	(2)	(1)	(1)	--

DIAGRAM NUMBER	PART NAME	Deluxe	Right	Left	Drop Zone
HARDWARE BAG F					
--	Socket Head Cap Screw 1/4-20x1/2"	(6)	(3)	(3)	--
--	SS Hex Head Screw w/ Hex End 1/4-20x1/2"	(4)	(2)	(2)	--
--	Oval Nut 1/4-20	(10)	(5)	(5)	--
HARDWARE BAG G					
★ ⑪	Stealth Stop	(2)	--	--	(2)
⑫	Clamping Miter Bar	(2)	--	--	(2)
--	Button Head Cap Screw #10-32x3/4"	(4)	--	--	(4)
--	Flat Head Cap Screw #10-32x3/8"	(2)	--	--	(2)
--	Nut #10-32	(4)	--	--	(4)
--	Oval Nut #10-32	(2)	--	--	(2)
HARDWARE BAG H					
--	Thin Wrench	(2)	(1)	(1)	--
--	Hex Key, 3/16"	(2)	(1)	(1)	--
--	Hex Key, 5/32"	(2)	(1)	(1)	--
--	Hex Key, 9/64"	(2)	(1)	(1)	--
--	Hex Key, 1/8"	(2)	(1)	(1)	--
⑬	Sliding Dovetail Pivot	(2)	(1)	(1)	--
--	Socket Flat Head Screw 1/4-20x1-1/4"	(2)	(1)	(1)	--
--	Nylock Nut 1/4-20	(2)	(1)	(1)	--
--	Shim Washer 1/4"	(2)	(1)	(1)	--
--	Hex Head Bolt 1/4-20x3/4" (Sled Block)	(4)	(2)	(2)	--
--	Aluminum Thumb Knob (Sled Block)	(4)	(2)	(2)	--

★ DENOTES ITEMS THAT ARE ALSO SOLD SEPARATELY

- L** Refers to the instructions for assembling the Left side.
- R** Refers to the instructions for assembling the Right side.

ASSEMBLY

I. SLED BASE & MITER BAR INSTALLATION

AT THIS POINT YOU WILL NEED:

- ① Sled Base
- ③ Miter Bar
- **HARDWARE BAG F**
 - Socket Head Cap Screw 1/4-20x1/2"
 - SS Socket Head Screw w/Hex End 1/4-20x1/2"
 - Oval Nut 1/4-20
- **HARDWARE BAG H**
 - Hex Key, 3/16"
 - Hex Key, 1/8"

YOU WILL ALSO NEED: Combination Square (*Not included*)

1. Insert the threaded ends of the (2) SS Socket Screws w/Hex End into both end countersunk holes (*on the T-Slot Washer side*) in the Miter Bar ③. From the other side of the Miter Bar loosely secure with (2) Oval Nuts. **FIGURE 1.**

2. Insert (3) Socket Head Cap Screws into the remaining countersunk holes on the Miter Bar. Loosely secure from the other side of the Miter Bar with Oval Nuts.

3. Slide the Oval Nuts on the Miter Bar into the slots on the bottom of the Sled Base ①. (*Leaf Springs facing inward on the Miter Bar.*)

4. **L** Take a measurement from the left side of your table saw blade to the inside wall of your left miter slot and subtract 1/32". **FIGURE 2.**

4. **R** Take a measurement from the right side of your table saw blade to the inside wall of your right miter slot and subtract 1/32".

5. Use a combination square and set it to match the measurement you just took in Step 4. **FIGURE 3.**

6. **L** Using the set combination square, set the Miter Bar to be parallel with the left edge of the Sled Base ① and tighten the (2) SS Socket Head Screws with a 3/16" Hex Key by turning counter-clockwise.

6. **R** Using the set combination square, set the Miter Bar to be parallel with the right edge of the Sled Base ① and tighten the (2) SS Socket Head Screws with a 3/16" Hex Key by turning counter-clockwise.

7. **L** Install the Sled Base in the left miter slot and verify that the Sled Base does not come in contact with your table saw blade.

7. **R** Install the Sled Base in the right miter slot and verify that the Sled Base does not come in contact with your table saw blade.

The Sled Base should be parallel and no more than 1/16" away from your table saw blade. If adjustments are needed, loosen (by turning clockwise) the end (2) SS SocketHead Screws from the top of the Sled Base with an 1/8" Hex Key and make your necessary adjustments.

8. Remove the Sled Base/Miter Bar and flip it back upside down on top of your table saw. Tighten the center (3) Socket Head Cap Screws with a 3/16" Hex Key to secure the Miter Bar in its final position on the Sled Base and tighten the (2) SS Socket Head Screws w/ Hex End at the ends.

9. **L** Re-install the Sled Base/Miter Bar into the left miter slot. Slide the Sled Base back so the sled overhangs the table saw to finish installing the remaining hardware.

9. **R** Re-install the Sled Base and Miter Bar into the right miter slot. Slide the Sled Base back so the sled overhangs the table saw to finish installing the remaining hardware.

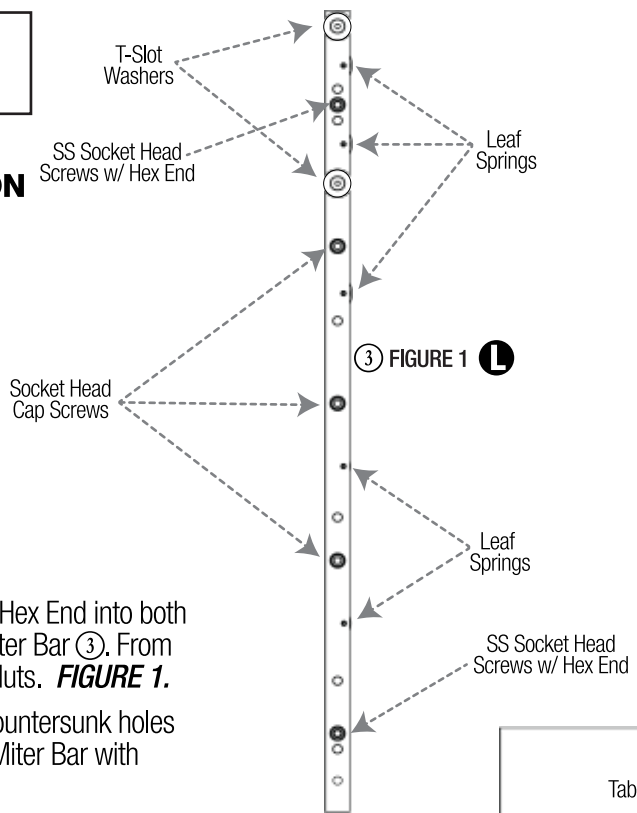

FIGURE 2 **L**

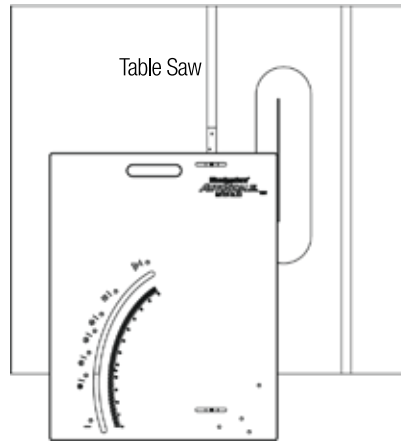
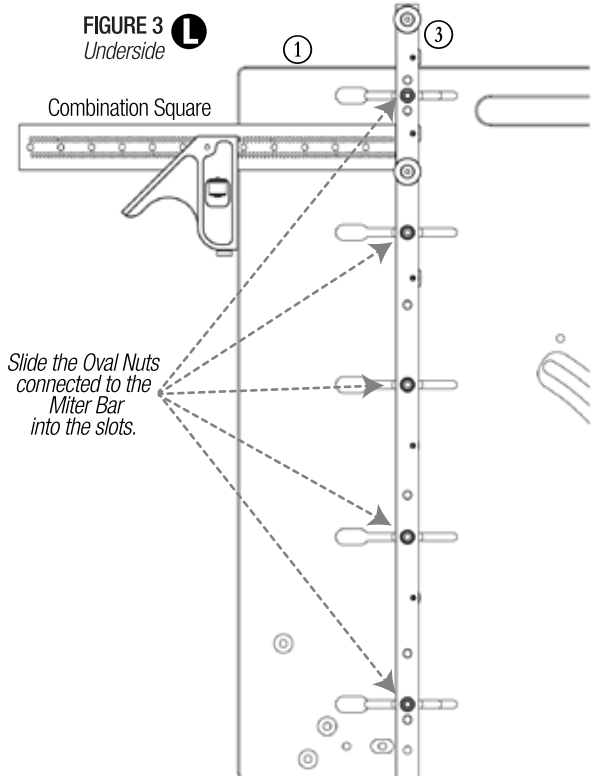

FIGURE 3 **L**
Underside



II. FENCE PIVOT ASSEMBLY & HOLD DOWN CLAMP BASE INSTALLATION

AT THIS POINT YOU WILL NEED:

- **HARDWARE BAG A**
 - ⑤ Hold Down Clamp
 - ⑥ Hold Down Clamp Base
 - Phillips Flat Head Screw 1/4-20x3/4"
- **HARDWARE BAG H**
 - Hex Key, 5/32"
 - ⑬ Sliding Dovetail Pivot
 - Socket Flat Head Screw 1/4-20x1-1/4"
 - Nylock Nut 1/4-20
 - Shim Washer 1/4"

1. From the underside of the Sled Base ① insert the Socket Flat Head Screw through hole "A". **FIGURE 4.**
2. From the topside of the Sled Base Slide the narrow end of the Sliding Dovetail Pivot ⑬ onto the Socket Flat Head Screw, then add a Shim Washer. **FIGURE 5.**
3. Loosely secure it with a Nylock Nut. Use a 5/32" Hex Key to loosely secure the Nylock Nut and the Socket Flat Head Screw .
4. From the underside of the Sled Base insert a Phillips Head Flat Head Screw through hole "B" and one through hole "C". **FIGURE 4.**
5. Thread the Phillips Head Flat Head Screws into the bottom of the Hold Down Clamp Base ⑥ to secure it in place.

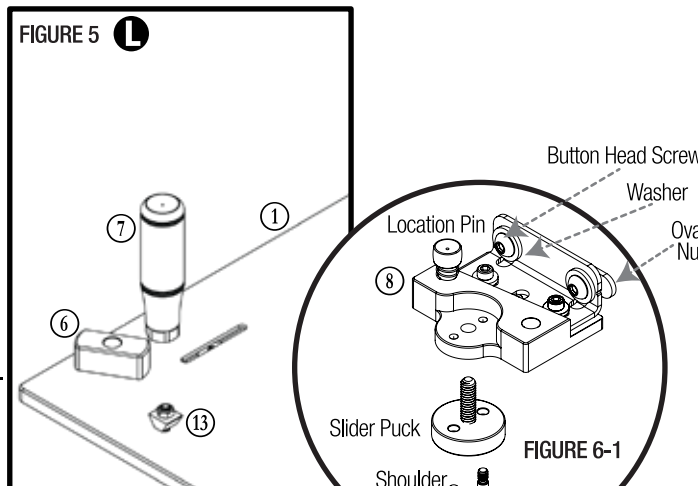
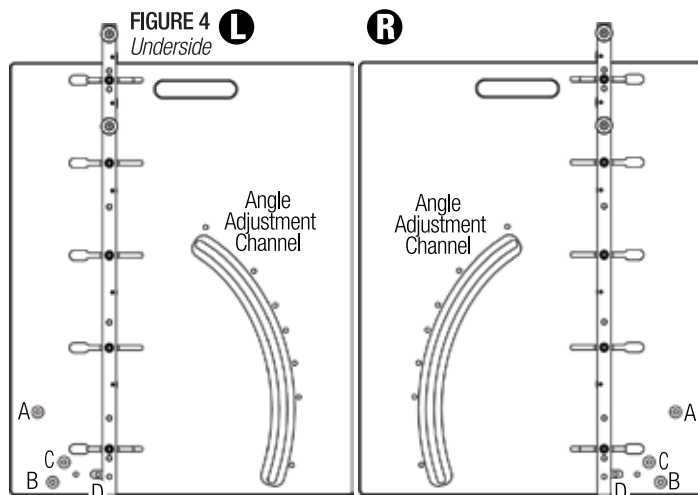

III. STATIONARY HANDLE INSTALLATION

AT THIS POINT YOU WILL NEED:

- **HARDWARE BAG B**
 - ⑦ Stationary Grip Handle
 - Hex Head Screw 1/4-20x3/4"

1. Unthread the Hex Screw in the Stationary Grip Handle ⑦ and insert it from the underside through hole D in the bottom of the Sled Base. Secure it from the top by tightly threading on the Stationary Grip Handle. **FIGURES 4 & 5.**

IV. CALIBRATION ASSEMBLY INSTALLATION

AT THIS POINT YOU WILL NEED:

- **HARDWARE BAG C**
 - ⑧ Calibration w/ Slider Puck Assembly *Left & Right Specific*
 - Shoulder Screw
 - Button Head Screw 1/4-20x3/4" *(Attached when shipped)*
 - Washer 1/4" *(Attached when shipped)*
 - Oval Nut, 1/4-20 *(Attached when shipped)*
- **HARDWARE BAG D**
 - ⑨ Pivot Grip Handle
- **HARDWARE BAG H**
 - Hex Key, 1/8"

1. Remove the (2) Shoulder Screws from the Slider Puck using the 1/8" Hex Key, to separate the Slider Puck from the Calibration Assembly ⑧. **FIGURE 6-1.**
2. From the topside, hold the Slider Puck in the Angle-Adjustment Channel in the Sled Base. Align the threaded holes of the Calibration Assembly with the Slider Puck from the underside. **FIGURE 6.**
3. Secure the Slider Puck to the Calibration Assembly with the (2) Shoulder Screws using the 1/8" Hex Key. Tighten. **FIGURE 7.**
4. Thread the Pivot Grip Handle ⑨ onto the Calibration Assembly. **FIGURE 8.**

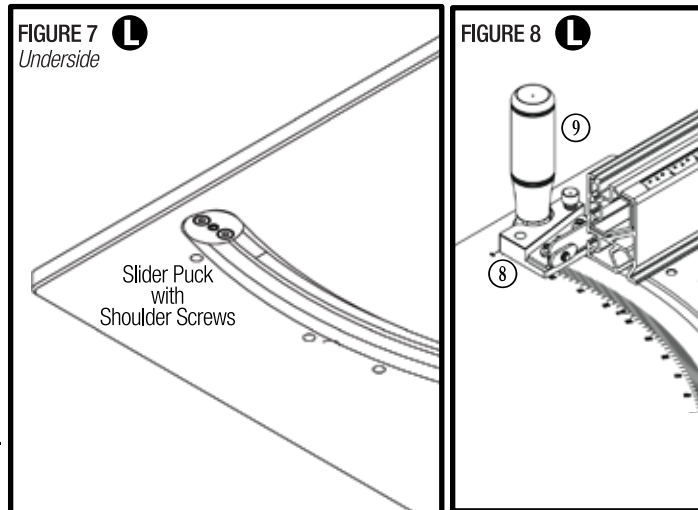
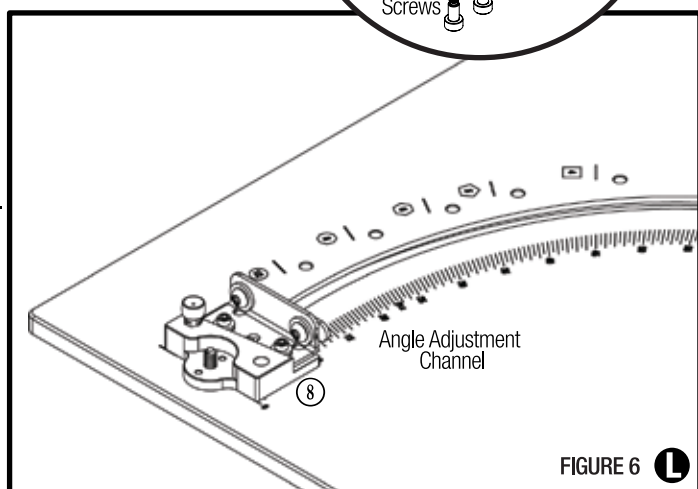

V. FENCE INSTALLATION

AT THIS POINT YOU WILL NEED:

② Fence Assembly *Left & Right Specific w/Multi-Knobs*

• HARDWARE BAG H

-- Hex Key, 5/32"

-- Thin Wrench

1. Attach the Fence Assembly ② by slotting the T-Slot Track (located on the back of the Fence) onto the Oval Nuts of the Calibration Assembly. **FIGURE 9.**

2. Slide the Fence down and onto the Sliding Dovetail Pivot ⑬. **FIGURE 10.**

3. Use the Thin Wrench and 5/32" Hex Key to tighten the Sliding Dovetail Pivot to apply downward pressure to the Fence. Tighten it until the Fence has no front and back play. The Fence must still slide freely from left-to-right. **FIGURE 11.**

4. Adjust the Fence until there is approximately a 1/4" gap between the edge of the Fence and the side of the Sled Base. *Calibration is in on page 6.*

5. Lock the left-to-right travel of the Fence into place by tightening the two Button Head Screws on the Calibration Assembly with a 5/32" Hex Key. **FIGURE 12.**

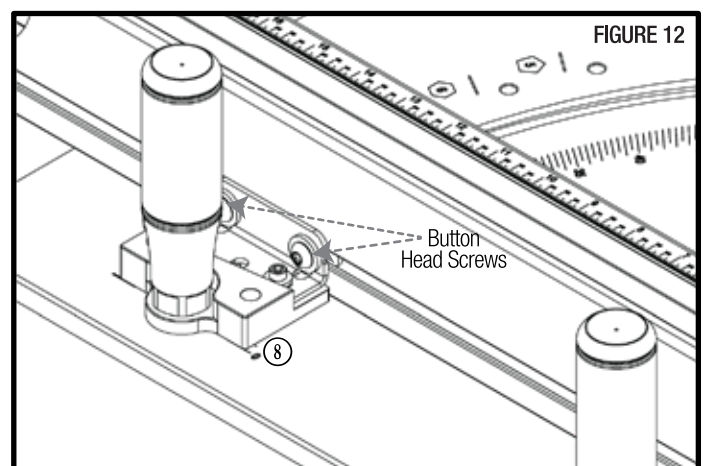
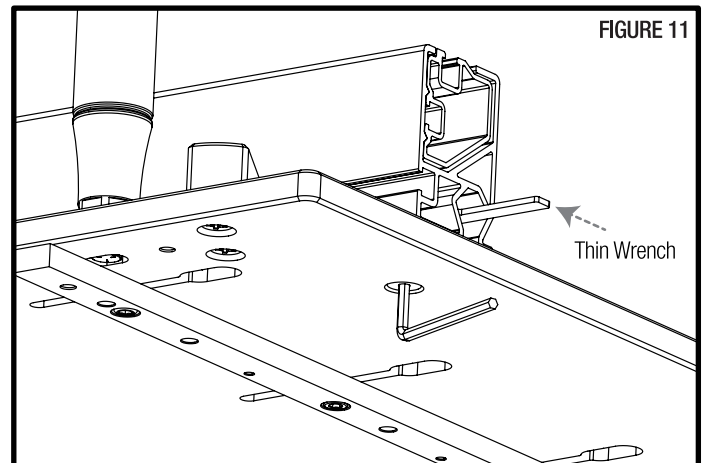
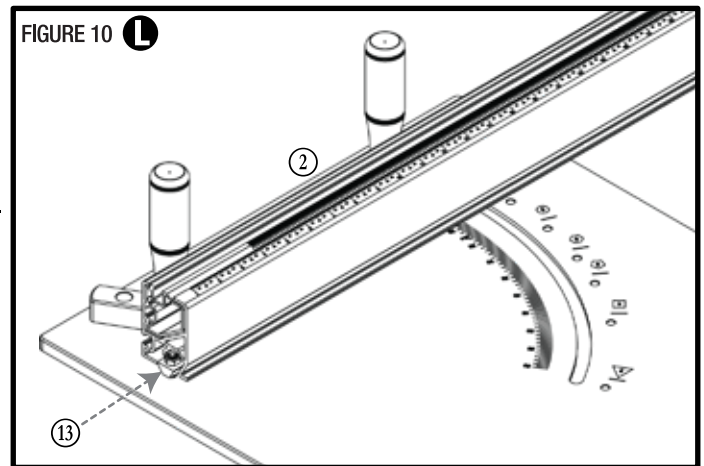
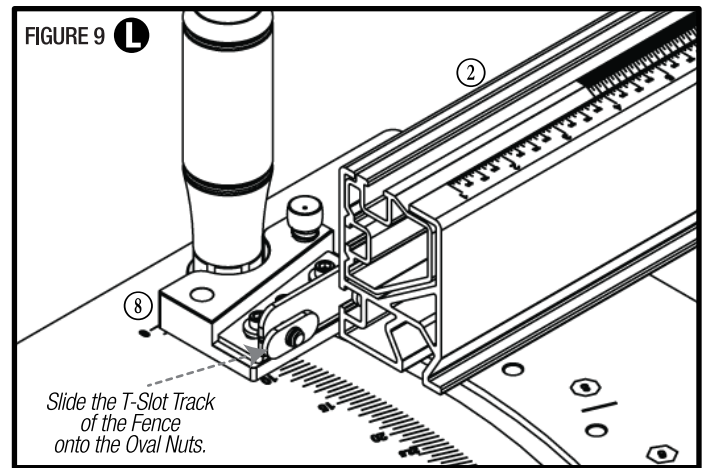

CALIBRATION

I. ADJUSTING THE FENCE FOR SQUARE

AT THIS POINT YOU WILL NEED:

• **HARDWARE BAG H**

- Hex Key, 9/64"
- Hex Key, 1/8"

NOTE: Prior to calibrating the Fence for square, ensure that your table saw blade is set to exactly 90° and that the blade is parallel to the miter slot. If any adjustment is needed, refer to your table saw's manual.

1. Begin the squaring process by aligning the Fence ② at the zero position. Loosen the Pivot Grip Handle ⑨ then press the Location Pin down on the Calibration Assembly and pivot the Fence until the Location Pin enters the zero index notch. Tighten the Pivot Grip Handle to secure the position of the Fence in place.

2. Make a test cut on a wide panel. Preferably 20"-24" wide, and check it for square.

3. Correct any squareness error by loosening the (2) Socket Head Screws, with a 9/64" Hex Key, just enough so the Calibration Bracket can slide.

FIGURE 12.

4. Use an 1/8" Hex Key in the Eccentric Cam to move the Calibration Bracket up or down. There are tick marks on the left side of the Calibration Bracket to use as a reference when making small adjustments.

- Turn the 1/8" Hex Key clockwise to move the Calibration Bracket to the left, lowering the Fence. *This makes your angle larger.* **FIGURES 14-A & 14-B.**

- Turn the 1/8" Hex Key counter-clockwise to move the Calibration Bracket to the right, raising the Fence. *This makes your angle smaller.* **FIGURES 14-A & 14-B.**

5. When the adjustment is made, pull the Fence towards the Pivot Grip Handle ⑨ to ensure there is no gap between the Calibration Bracket and the Calibration Base then re-tighten the Socket Head Screws.

- Repeat these steps, rechecking for squareness until you have reached a satisfactory result.

II. CALIBRATE THE FENCE SCALE

AT THIS POINT YOU WILL NEED:

• **HARDWARE BAG E**

⑩ Flip Stop *Left & Right Specific*

1. Insert the Flip Stop ⑩ into the top of the Fence by slotting the Oval Nut in the T-Track. **FIGURE 13-A.** Slide the Flip until the inside of the flag is directly over the 1" mark, and lock it down. **FIGURE 13-B.**

2. Loosen the (2) Button Head Screws on the Calibration assembly with a 5/32" Hex Key. Slide the Fence until the edge of the Flip Stop comes in contact with the tooth of your saw blade. Then secure the Fence in place by re-tightening the (2) Button Head Screws on the Calibration assembly. Your Fence Scale is now calibrated. **FIGURE 12.**

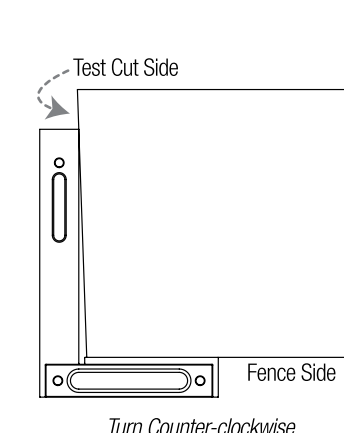
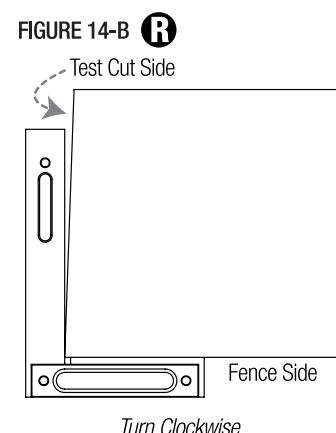
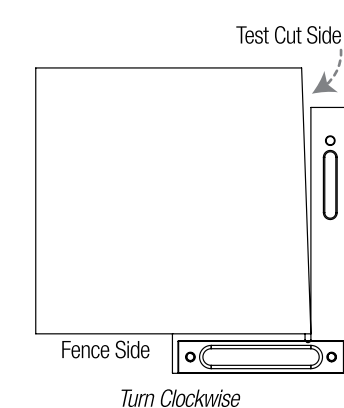
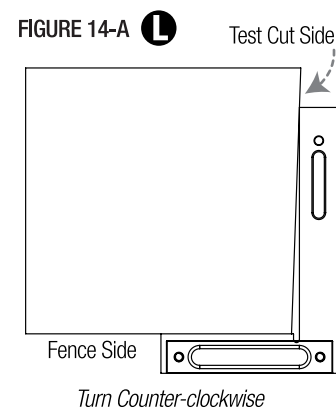
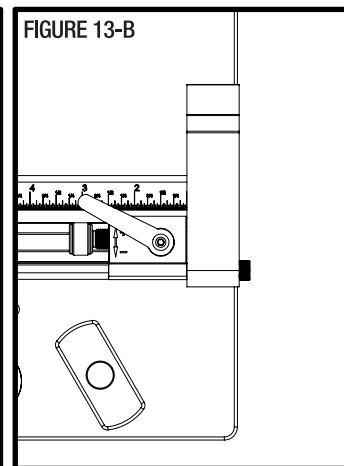
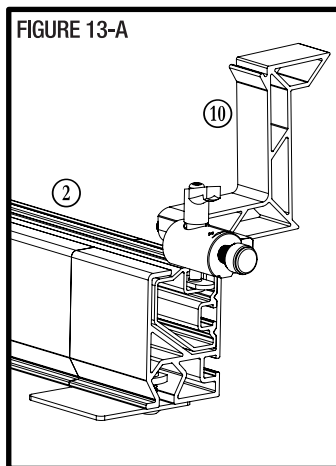
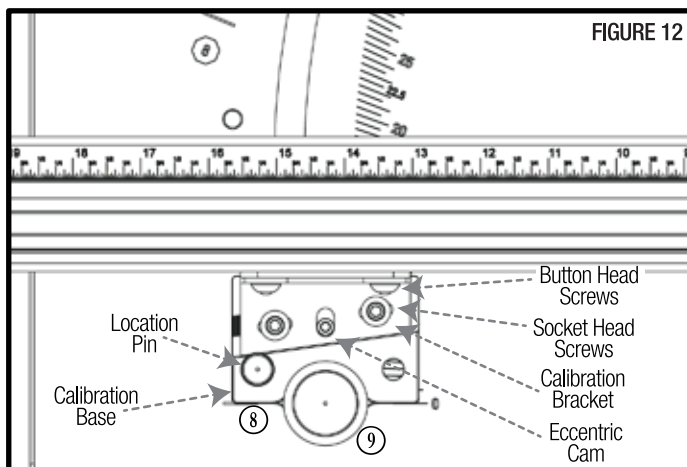

III. CALIBRATE THE FENCE EXTENSION SCALE

AT THIS POINT YOU WILL NEED:

- **HARDWARE BAG E**
 - ⑩ Flip Stop *Left & Right Specific*
- **HARDWARE BAG H**
 - Hex Key, 1/8"

1. Loosen the Fence Extension Knob on the Fence and extend the inner Fence Extension until it stops.
2. Lock the Fence Extension in place by locking the Fence Extension Knob. Align the inside edge of the Flip Stop ⑩ with the 27" mark on the Fence Extension and lock it in place. If the 27" mark on the inner and outer Fence do not line up, then proceed to steps #3 and #4. **FIGURE 15.**
3. If the 27" marks do not line up, loosen the stop on the back of the fence with an 1/8" Hex Key. Loosen the Knob on the Fence and nudge the Fence over until the two 27" marks align. Then re-tighten to lock the Fence. **FIGURES 15 & 15-A.**
4. With the Fence locked in the correct position, use a Hex Key to push square nut stop into the fixed stop and hold it while re-tightening with the 1/8" Hex Key.

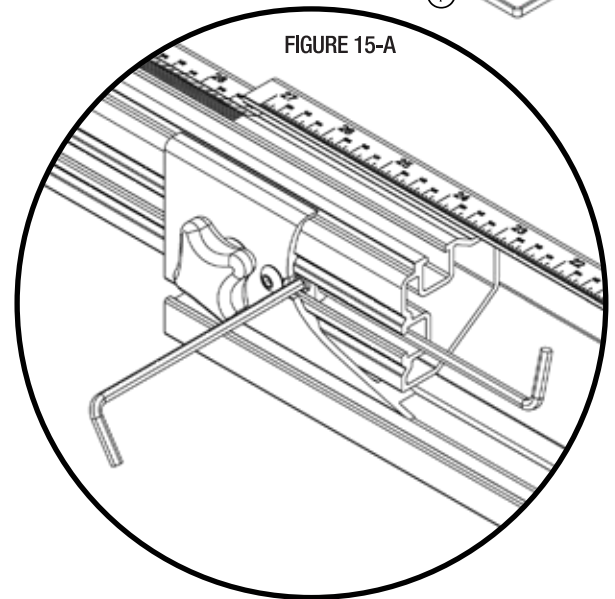
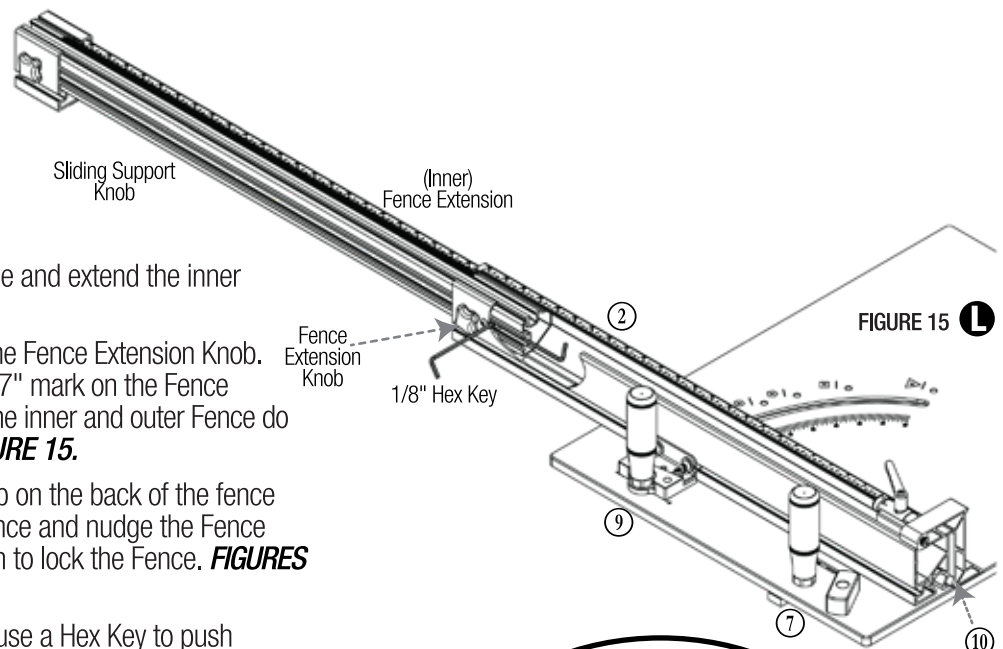

DROP ZONE

I. STEALTH STOPS

AT THIS POINT YOU WILL NEED:

- **HARDWARE BAG G**
 - ⑪ Stealth Stop
- **HARDWARE BAG H**
 - Hex Key, 1/8"
- The StealthStop ⑪ is tool-free for raising/lowering the flag, and for micro-adjusting position. It does require the 1/8" Hex Key to lock the stop in place. When lowered, the StealthStop is fully below the surface of the track and out of the way. **FIGURES 16 & 16-A.**

II. CLAMPING MITER BAR & DROP ZONE ASSEMBLY

AT THIS POINT YOU WILL NEED:

- ④ Drop Zone Base
- **HARDWARE BAG G**
 - ⑫ Clamping Miter Bar
 - Button Head Cap Screw #10-32x3/4"
 - Flat Head Cap Screw #10-32x3/8"
 - Nut #10-32
 - Oval Nut #10-32
- **HARDWARE BAG H**
 - Hex Key, 1/8"

YOU WILL ALSO NEED: Combination Square (Not included)

1. Insert a Flat Head Cap Screw through the center countersunk hole in the Clamping Miter Bar ⑫. Loosely thread an Oval Nut onto the Flat Head Cap Screw using an 1/8" Hex Key. Repeat for the second Clamping Miter Bar. *This Flat Head Cap Screw will be tightened in later steps to expand the Clamping Miter Bar to create a tight fit in the miter slot.* **FIGURE 17** (Next page).
2. Install (2) Nuts into the hexagon countersunk hole on each Clamping Miter Bar. This can be easily done by threading the nut onto the end of a Button Head Cap Screw, and then press them into place by hand. Once installed, remove the Button Head Cap Screw.

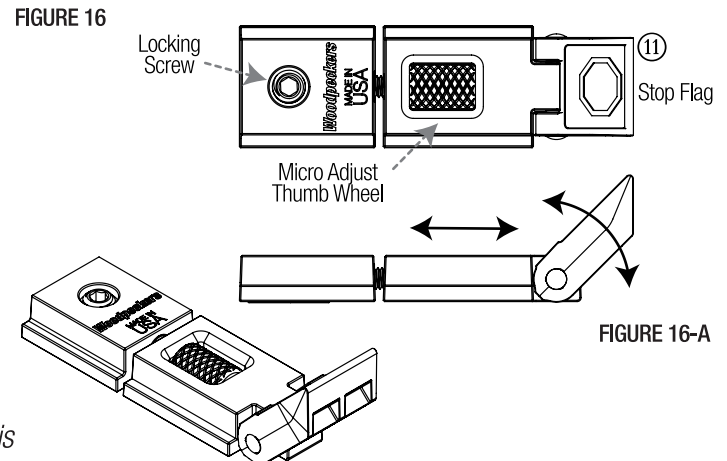

3. Orient the Clamping Miter Bar on the bottom of the AutoScale Miter Sled as shown. The thinner edge of the Clamping Miter Bar should be facing the handle side of the Drop Zone ④. **FIGURE 18.**

4. Secure the Clamping Miter Bar to the Drop Zone by inserting (2) Button Head Cap Screws through the countersunk/elongated slots in the top of the Drop Zone. Thread the Flat Head Cap Screws into the (2) Nuts in the Clamping Miter Bar. Loosely secure them at this time, you should still be able to slide them left and right. **FIGURE 17.**

5. **L** Take a measurement from the right side of your table saw blade to the inside wall of your right miter slot and subtract 1/16".

5. **R** Take a measurement from the left side of your table saw blade to the inside wall of your left miter slot and subtract 1/16".

6. Use a combination square and set it to match the measurement you just took.

7. Using the combination square, set the Clamping Miter Bars to be parallel with the edge of the Drop Zone that does not have the hand cut-out, and tighten the (2) Button Head Cap Screws with an 1/8" Hex Key to secure the Clamping-Miter Bars in place.

8. **L** Install the Drop Zone into the right miter slot of your table saw. Verify that the Drop Zone does not come in contact with the blade. If it does, make any necessary adjustment by repeating the previous steps. The edge of the Drop Zone should be parallel, and 1/16" away from your table saw blade.

8. **R** Install the Drop Zone into the left miter slot of your table saw. Verify that the Drop Zone does not come in contact with the blade. If it does, make any necessary adjustment by repeating the previous steps. The edge of the Drop Zone should be parallel, and 1/16" away from your table saw blade.

9. Increase the clamping pressure of the Miter Clamping Bars with the Drop Zone installed, by tightening the (2) Flat Head Cap Screws with an 1/8" Hex Key. Do not over-tighten the Flat Head Cap Screws.

NOTE: To test the fit, slide the Drop Zone forward and backward checking to see that it still moves, but has adequate resistance. There should be enough resistance that the Drop Zone remains in place while using it to support the off-cut of your workpiece. Lastly, test to see that you can remove and re-install the Drop Zone in your table saw t-slot. While installed there should be no left-to-right play.

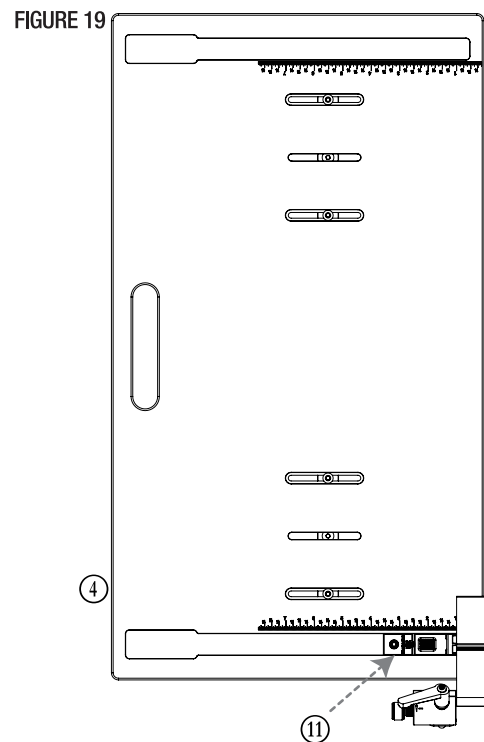
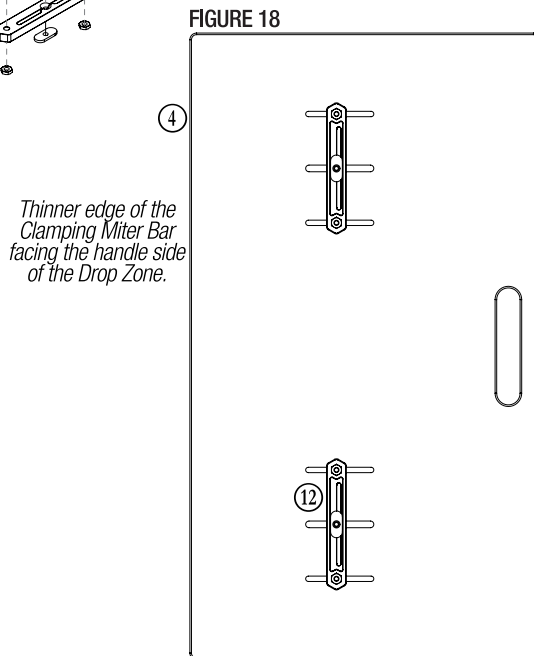
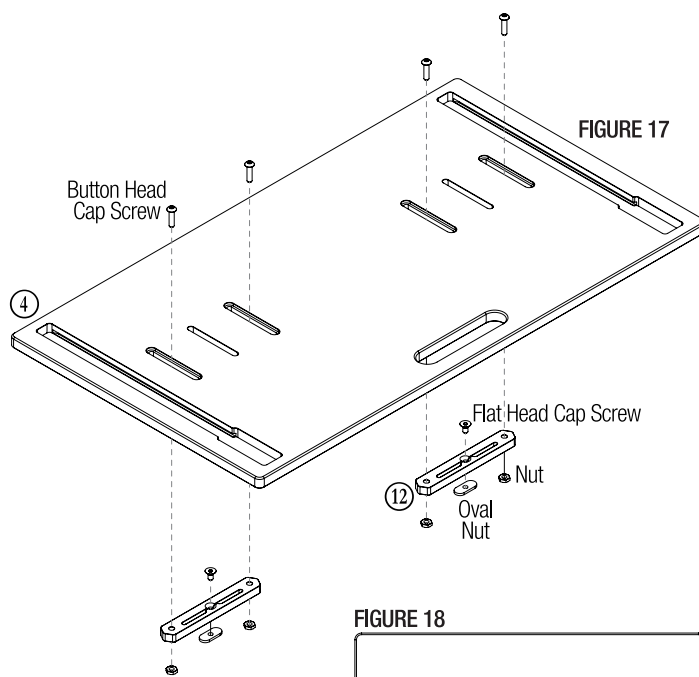

III. DROP ZONE CALIBRATION

1. Begin by installing a StealthStop ⑪ in the Drop Zone ④. Use a square to assist in setting the Stealth Stop at the 1" mark. When you get it in place, lock it down with the 1/8" Hex Key. **FIGURE 19.**

2. Using the Flip Stop Flag from the AutoScale Miter Sled as a 1" gauge block. Place it between the Stealth Stop and your table saw blade. Ensure that it fits snug. If left-to-right adjustment is needed to dial in the scale, simply loosen the Button Head Screws on the Miter Clamping Bars to adjust the Drop Zone, and then re-tighten the Button Head Screws.

SLED BLOCKS (Optional)

FIGURE 20

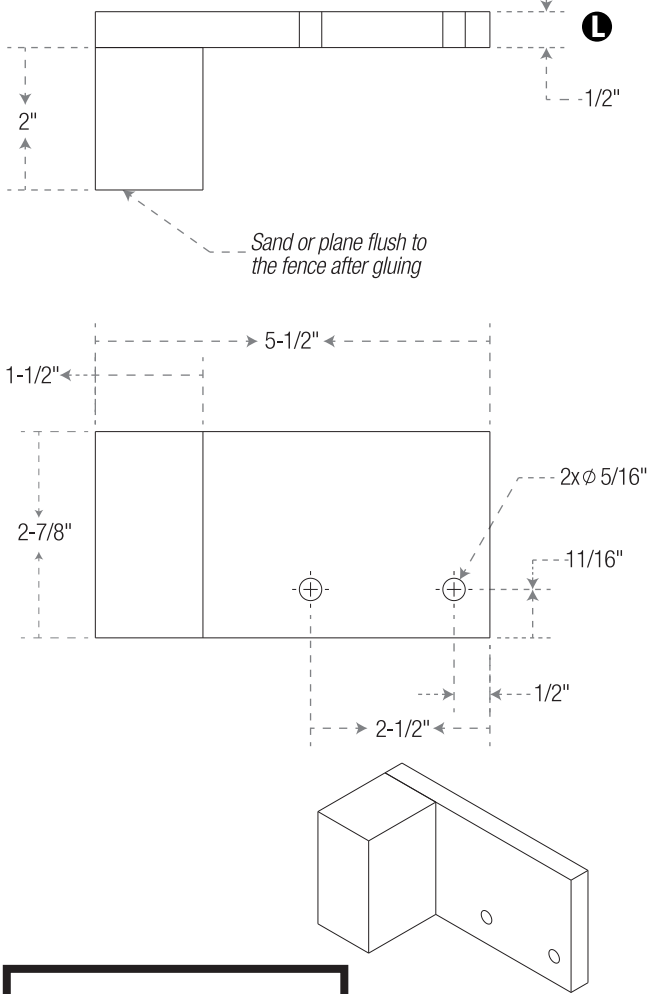
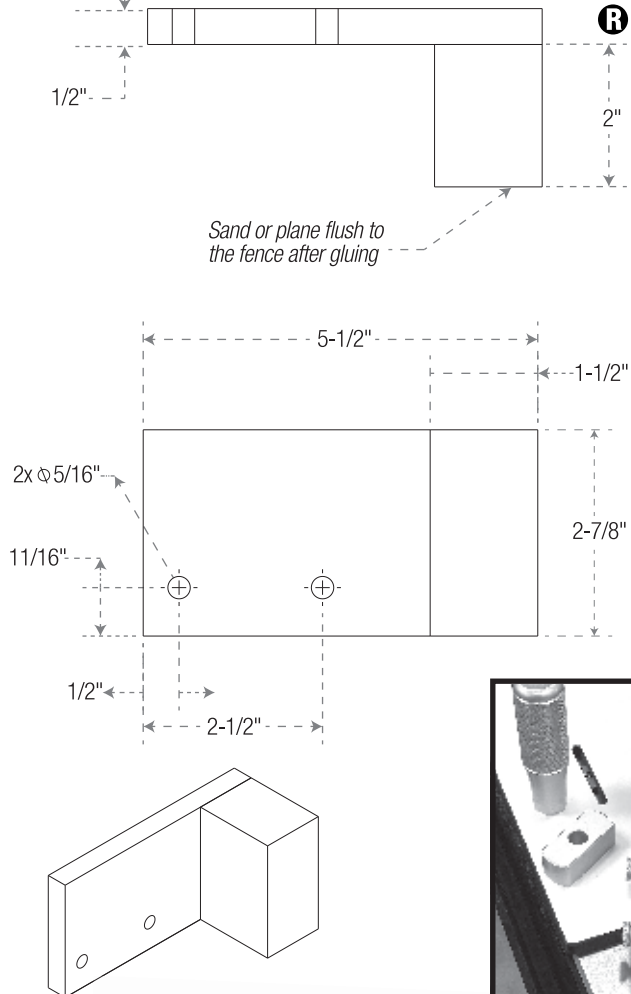

FIGURE 20-A



Scan the QR code above to watch this video to see step by step how to make a batch of Sacrificial Sled Blocks for your AutoScale Miter Sled.

AT THIS POINT YOU WILL NEED:

- **HARDWARE BAG H**
 - Hex Head Bolt 1/4-20x3/4" (Sled Block)
 - Aluminum Thumb Knob (Sled Block)

YOU WILL ALSO NEED: 1/2" Plywood & 6/4" Stock Wood *(Not included)*

Use the diagrams above to make a sacrificial sled block for your AutoScale Miter Sled. **FIGURES 20 & 20-A.**

How to Install:

1. Insert the Hex Head Bolts through the two holes and loosely secure them with the Aluminum Thumb Knobs. **FIGURE 21**.
2. Adjust the angle of the AutoScale Fence to 22.5°.
3. Slide the heads of the Hex Head Bolts into the rear slot on the back of the Fence of the AutoScale Miter Sled.

FIGURES 22, 23, 24.

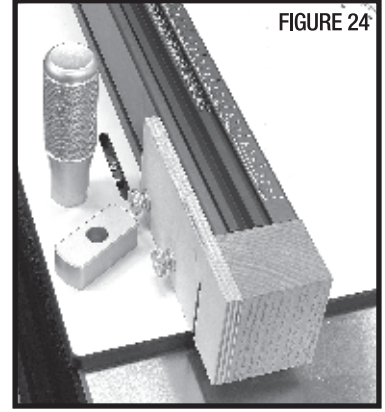
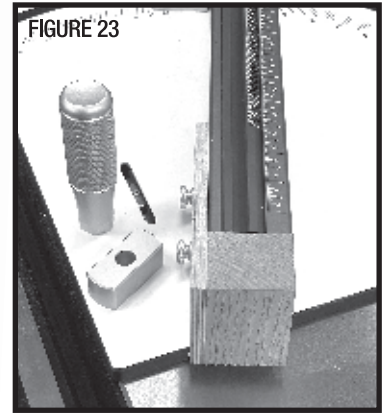
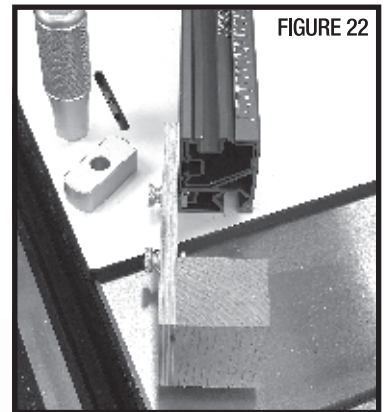
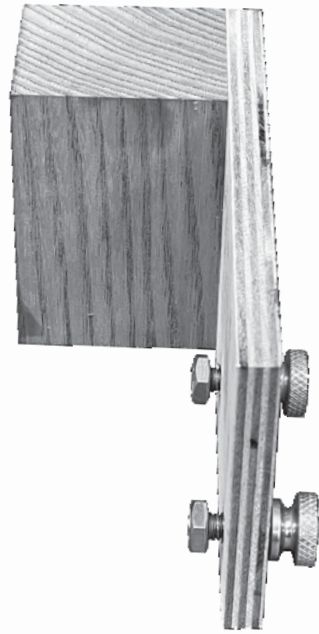

FIGURE 21



HOW TO USE THE AUTOSCALE MITER SLED

• To set your desired cut angle, loosen the Pivot Grip Handle, move your Fence to the desired angle indicated by the scale, and re-tighten the Pivot Grip Handle.

NOTE: If you are setting your angle to 0°, 15°, 22.5°, 30°, 36°, 45°, or 60°, there is a Location Pin on the Calibration Assembly that you can press down to index on any one of those pre-set angles. To use it, set the Fence close to your angle, then press and hold down the Location Pin with one hand until it is properly indexed, and use your other hand to tighten the Pivot Grip Handle to secure the Fence position in place.

The numbers near the index holds (along with the coordinating shape images) indicate the number of sided shape that angle miter makes. **FIGURE 27-A.** (Next page).

• **Flip Stop ⑩** - Loosen the black Lever on top of the Flip Stop and slide it to the desired dimension. The scale reads directly to the inside edge of the Flip Stop itself.

- To micro-adjust the position of the Flip Stop, spin the knurled brass Thumb Wheel to move the Flag forward or backward. **FIGURE 27** (Next page).

- To raise / lower the Flag, simply use your finger tip to snap it up or down.

• **Scale** - With the Fence in the collapsed state, the Flip Stop can reach up to 27". To set the Flip Stop to a longer measurement, loosen the Knob on the back of the Fence and slide the Fence out all the way to the stop and re-tighten. When the Fence is extended the Flip Stop will reach from 22-1/4" to 50-1/4".

NOTE: To use the Fence Extension, it must be fully extended for the Scale to be accurate. If the Fence is only partially extended, the Scale will no longer read correctly on the telescoping section. You only have to calibrate your Fence Extension Scale once.

• **Long Part Support** - When the Fence is extended and handling workpieces longer than 30", the Long Part Support should be used to keep the workpiece from tipping off the Sled. To use it, loosen the Knob on the back and slide it near the Flip Stop. The support can be placed directly under the Flip Stop for maximum support at the very end, but it doesn't need to be. It can be placed anywhere that keeps the workpiece from tipping. **FIGURE 25.**

• **Hold Down Clamp ⑤** - It is important to use the Hold Down Clamp when making cuts. It ensures your workpiece stays put for accurate cuts and it keeps your hands safely on the handles. The Hold Down Clamp can slide in and out of the base for easy storage and installation. To use the Hold Down Clamp, ensure it is installed all the way down in the Sled Base then slide the arm down to the material so the foot touches the workpiece. Then turn the Knob clockwise to firmly clamp your material in place. **FIGURES 26 & 27** (Next page).

• **Stealth Stop ⑪** - To lock/unlock the StealthStop, use the Hex Key in the exposed hex of the locking screw. **FIGURE 27** (Next page).

- To move the StealthStop around quickly, use the Hex Key to loosen the lock, and then move the stop with the Hex Key still installed.

- To micro-adjust the position of the StealthStop, spin the knurled brass thumb wheel to move the flag forward or backward.

- To raise / lower the Stop Flag, simply use your finger tip to snap it up or down.

- To set the StealthStop to a specific dimension, flip up the Stop Flag and push the workpiece against the stop, read the scale where it intersects the workpiece. If the workpiece does not intersect the scale, use a small square (such as the Woodpeckers MiniSquare, Not Included) to read the scale.

• **Extended Fence** - To use your Extended Fence, remove the Flip-Stop, Long Part Support, and Sled Block (if using). Then loosen the Fence Extension Knob and slide the inner fence towards the blade side of the sled to fully remove it. Slide the Extended Inner Fence back through the same side until fully extended. Replace the Flip-Stop, Long Part Support, and Sled Block (if using). If it's your first time installing the Extended Inner Fence, follow the instructions in Calibration Section III (Page 8).

NOTE: The Fence will no longer fully collapse when the Extended inner fence is installed.

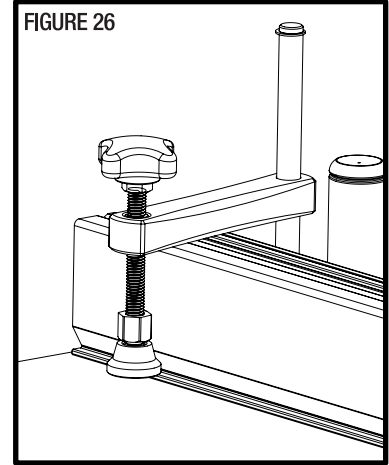
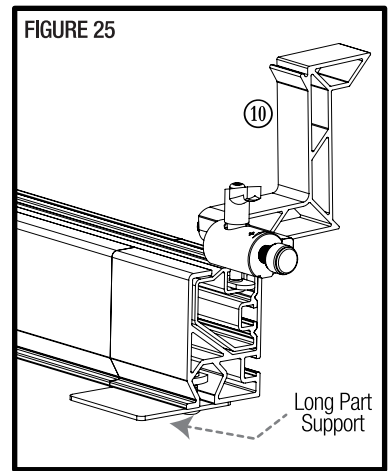

FIGURE 27-A

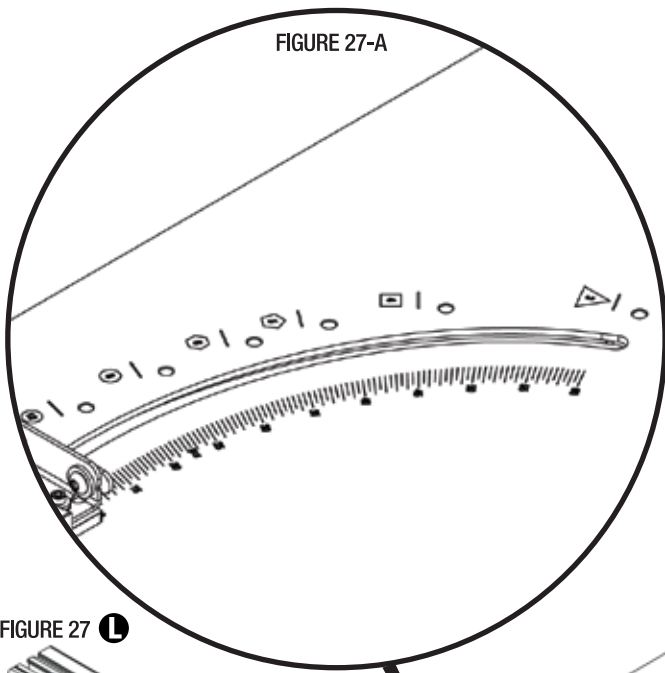
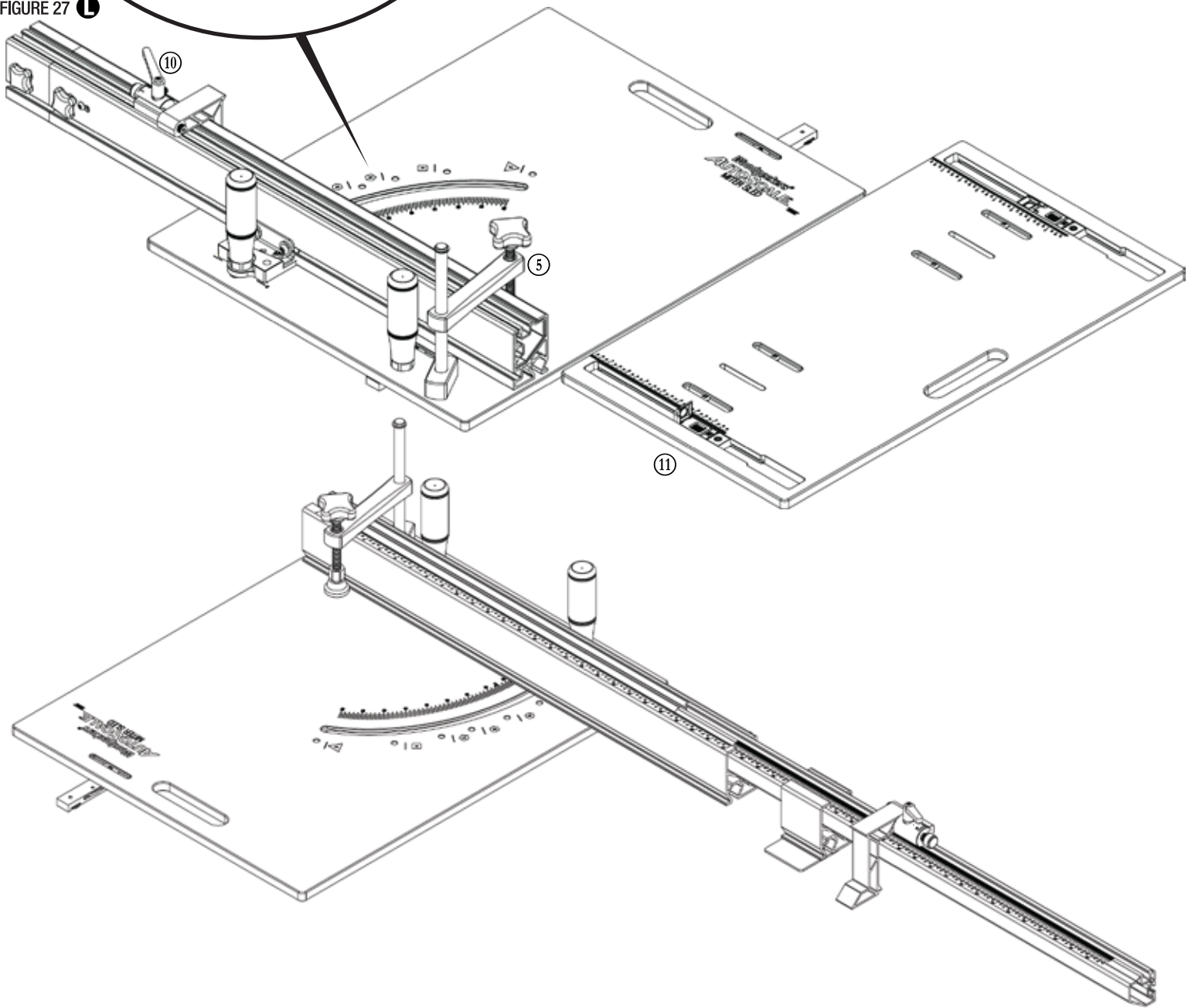

FIGURE 27 L



Woodpeckers®

Woodpeckers, LLC Strongsville, Ohio
woodpeck.com
© 2022 Woodpeckers, LLC



woodpeck.com

At Woodpeckers we are constantly reviewing & improving our tools. The most current version of our instruction manuals are always available to download at **woodpeck.com.**

(Located in the bottom section of the tool's page under the "Additional Information" or "Instructions" tabs.)



Be the first to know all the new products, *OneTIME Tools* & sales by subscribing to our eClub. *(Located at the top center of our webpage **woodpeck.com**.)*



Subscribe to our YouTube channel to stay up-to-date on all the latest tool tips & tricks.



INTERACT WITH US! Follow us on Facebook, Instagram & TikTok!



Enjoy shop tips, project ideas, tool techniques & more in our Woodworking Resource Center/Blog. *(Located at the bottom center of our webpage **woodpeck.com**.)*



WARNING! To reduce the risk of injury keep hands away from moving parts. Refer to your power tool manual for proper setup and use.



WARNING! To reduce the risk of injury, wear safety goggles or glasses with side shields, ear protection & a dust mask.



WARNING! This product can expose you to chemicals, including chromium, which is known to the State of California to cause cancer and birth defects or other reproductive harm. For more information go to www.P65Warnings.ca.gov