

# Woodpeckers®

## IRON-GRIP™ CLAMP UPGRADE

for the WOODPECKERS COPING SLED (COPEsled1)

O W N E R ' S M A N U A L

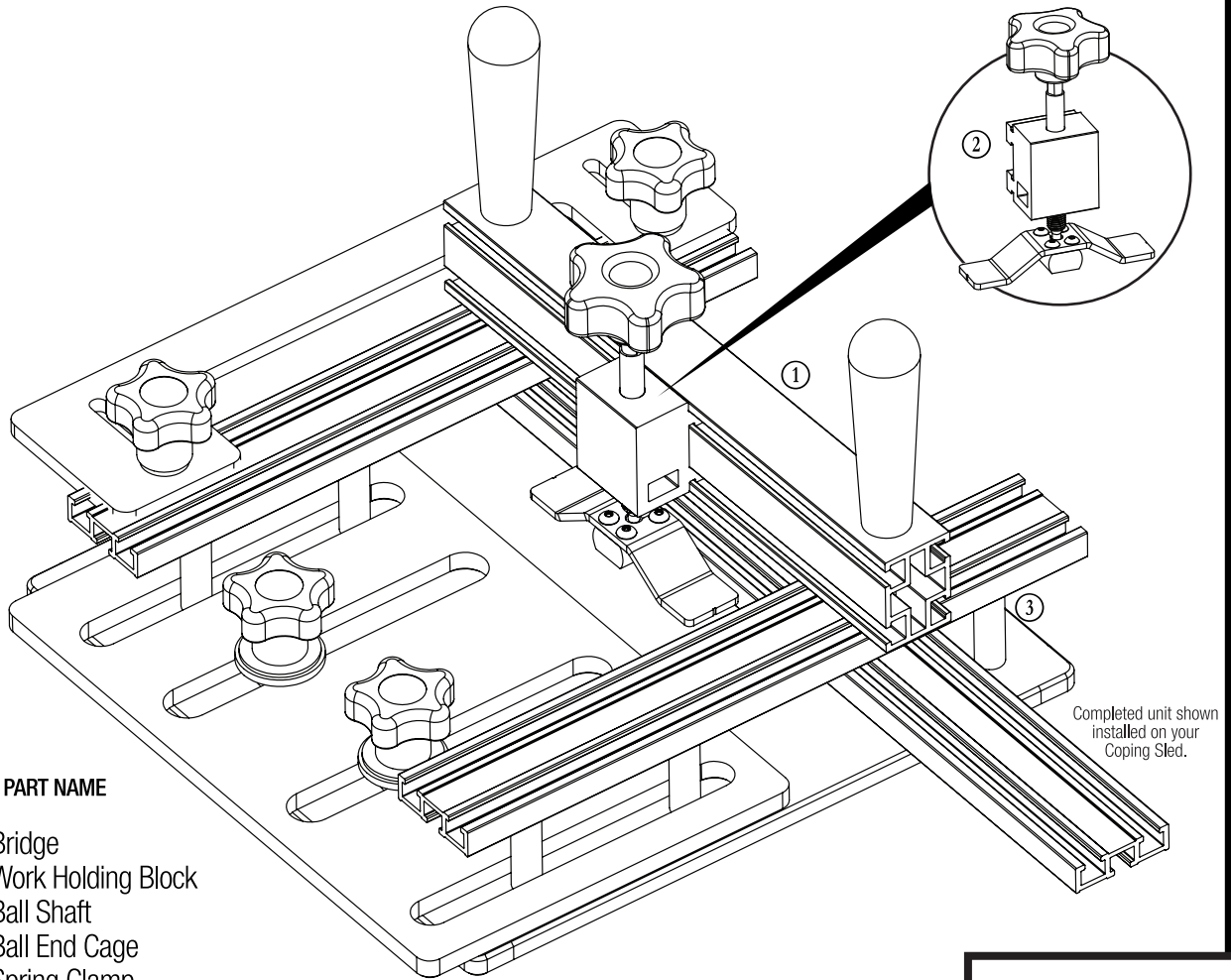

DIAGRAM (QTY) PART NAME  
NUMBER

- |   |                                     |
|---|-------------------------------------|
| ① | (1) Bridge                          |
| ② | (1) Work Holding Block              |
|   | (1) Ball Shaft                      |
|   | (1) Ball End Cage                   |
|   | (1) Spring Clamp                    |
| ③ | (1) Black Woodpecker Knob, 5/16     |
|   | (1) Hex Nut, 3/8-16                 |
|   | (4) Button Head Screw, 8-32 x 5/16" |
|   | (6) Spacer Tube                     |

### HARDWARE BAG A

- |   |
|---|
| (2) Hex Head Bolt, 1/4-20 x 2-1/2"                    |
| (6) Phillips Flat Head Machine Screw, 1/4-20 x 2-3/4" |
| (2) Weldnut, 1/4-20                                   |



Scan the QR code above  
to watch the video  
or visit [woodpeck.com](http://woodpeck.com)  
under the video tab towards  
the bottom of the product page.

If you think you're missing anything, email us at [mailroom@woodpeck.com](mailto:mailroom@woodpeck.com).  
You can also call us at 800-752-0725 from 9:00 a.m. to 4:00 p.m. EST Monday - Friday.

## I. DISASSEMBLING YOUR ORIGINAL COPING SLED

1. Loosen and remove the star knobs and acrylic guide. Set this assembly to the side as it will be re-used. **FIGURE A.**

2. Loosen the handles from the bridge. Completely remove just the handles and set them to the side to be re-used. The bridge assembly and bolts that were used with the handles may be discarded. **FIGURE B.**

3. Flip the coping sled upside-down and use a flat head screwdriver to loosen the 4 corner screws. Flip the coping sled upright and remove the top tracks by sliding them off of the spacer tubes and weldnuts.

4. Completely remove the 4 corner flat head screws, 4 spacer tubes, and 4 weldnuts. The 4 weldnuts and the top track are the only hardware that will be re-used. **FIGURE C.**

**FIGURE A.**

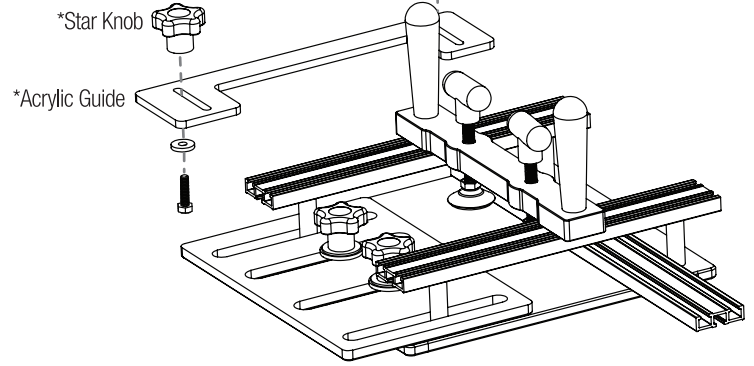

**FIGURE B.**

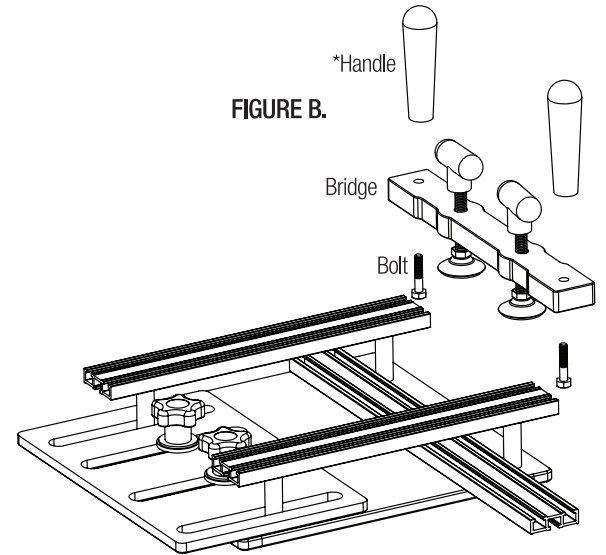

**FIGURE C.**

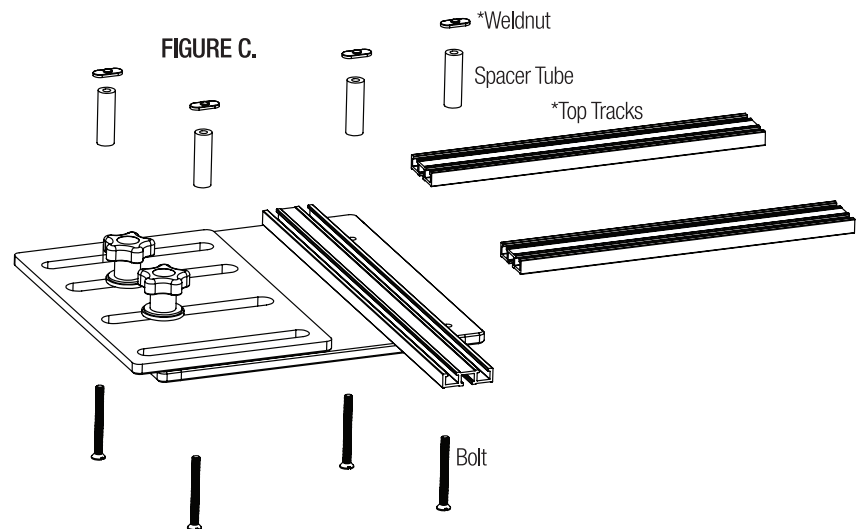

## II. ASSEMBLING YOUR NEW IRON-GRIP COPING SLED

### AT THIS POINT YOU WILL NEED:

- ① Bridge
- ② Work Holding Clamp
- ③ Spacer Tube (6)
- **HARDWARE BAG C**
- Hex Head Bolt, 1/4-20 x 2-1/2" (2)
- Phillips Flat Head Machine Screw, 1/4-20 x 2-3/4" (6)
- Weldnut, 1/4-20 (2)
- **RE-USED HARDWARE**
- \*Star Knob (2)
- \*Acrylic Guide Assembly
- \*Handle (2)
- \*Weldnut (2)
- \*Top Track (2)

1. Insert the (6) Phillips Flat Head Machine Screws up through the bottom of the base in the 4 corner holes and the 2 center holes. From the top add Spacer Tubes ③ and Weldnuts onto each Phillips Flat Head Machine Screws. Do not tighten.

#### FIGURE D.

2. Slide the \*top tracks onto the Spacer Tube assemblies with the single-track side down, until all three Weldnuts are captured in the slot of the top track.

3. Align the top tracks even with the edge of the base. Firmly tighten the Phillips Flat Head Machine Screws in the Spacer Tube Assemblies from underneath to secure the top track.

4. Slide the Hex Head Bolts into the outside slot of each top track.

5. Slide the Work Holding Clamp ② onto the t-slot track on the Bridge ①. **FIGURE E.**

6. Place the Bridge with the Work Holding Clamp installed so that the Hex Head Bolts pass through the pre-drilled holes in the Bridge.

7. Thread on the 2 \*handles to lock the Bridge in place.

8. Re-install the \*star knobs and \*acrylic guide to the front top track using the \*nylon washer and \*hex head bolts as shown.

#### FIGURE F.

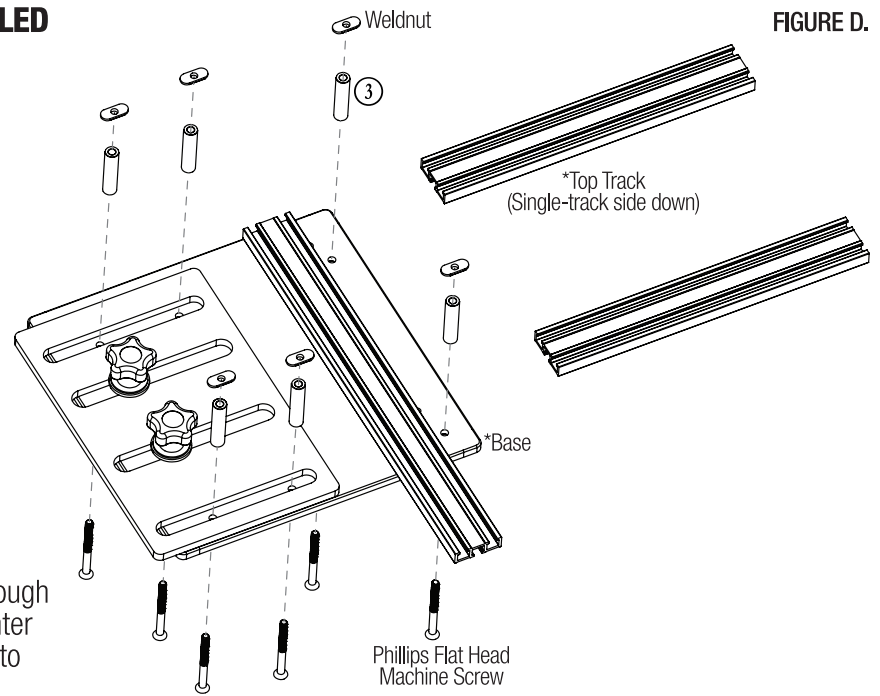

FIGURE D.

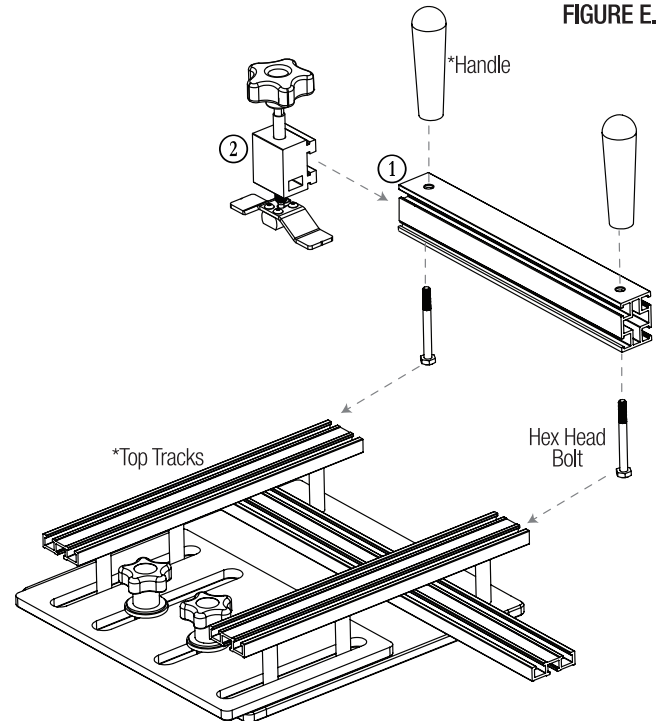

FIGURE E.

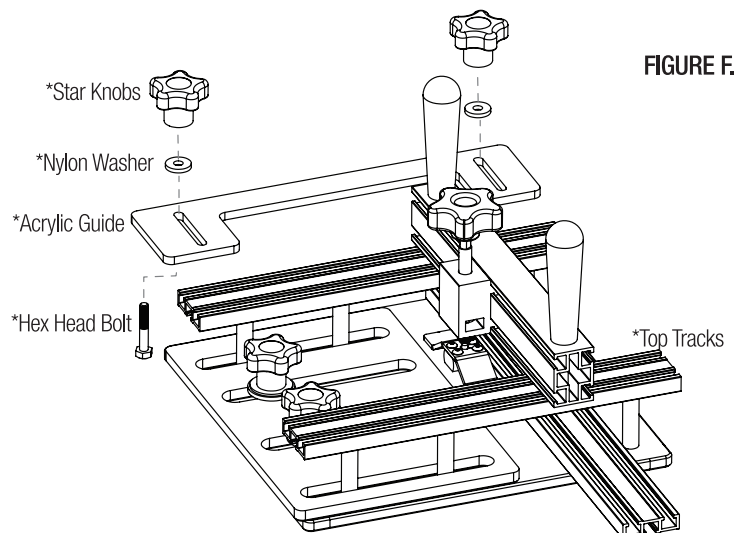

FIGURE F.

### III. SETTING THE ACRYLIC GUIDE

Setting the Acrylic Guide only takes a minute, but is vital for proper operation.

1. First loosen the two Knobs that secure the Acrylic Guide to the Top Track.
2. Insert a straight 3/4" scrap wood spacer between the Base and your router fence. The scrap wood spacer may need to be thicker for extremely deep routing cuts. Size your spacer to prevent contact. **FIGURE G.**
3. While holding the Iron-Grip Coping Sled against the scrap wood spacer and the router fence, slide the Acrylic Guide up against the router fence and tighten the two Knobs.

**NOTE:** The Acrylic Guide should be the only part of the Coping Sled that run against the router fence during use. **At no time should the Base come in contact with the router fence or the router bit.** For large cutters, it may be necessary to use a wider spacer.

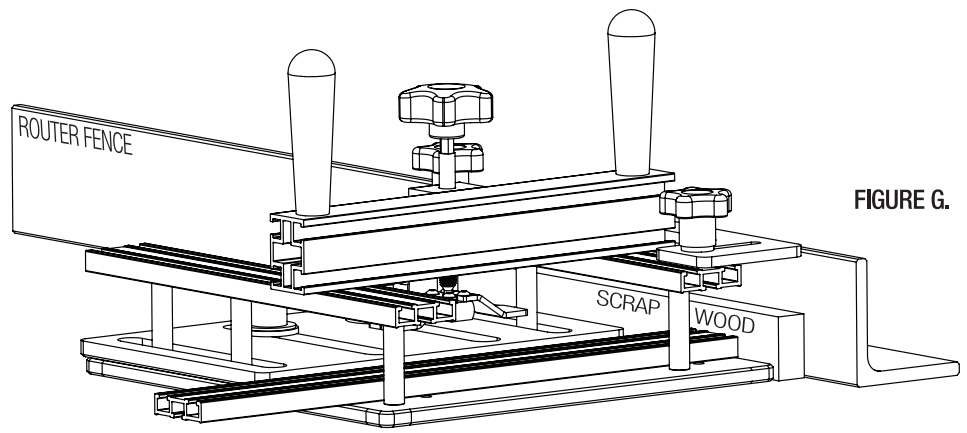

FIGURE G.

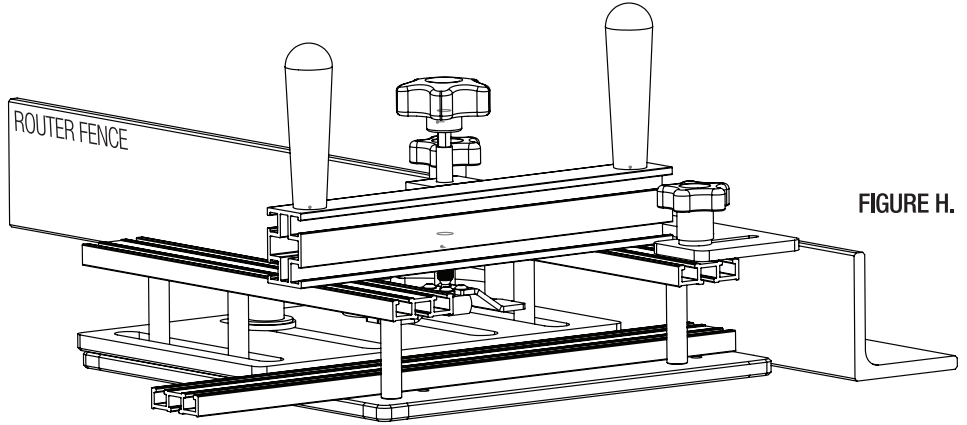

FIGURE H.

### IV. INSTALLING YOUR WORKPIECE.

1. Install your work-piece by placing it on the Base. Ensure the Acrylic Guide is pressed tight against the fence, then slide the workpiece forward against the fence. **FIGURE H.**
2. To prevent tear out, install a sacrificial piece between the work piece and the fence.
3. Use the Top Plate to press the work piece firmly against the sacrificial fence and tighten the Knobs .
4. Position the Work Holding Clamp over the center of the board and turn the Knob to clamp the board in place.
5. For a step-by-step on how to make rail and stile doors, scan this QR code. It will take you to our YouTube channel where you can learn how to get the most out of your Iron-Grip Coping Sled.



Scan the QR code above to watch the video or visit [woodpeck.com](http://woodpeck.com) under the video tab towards the bottom of the product page.

# Woodpeckers®

Woodpeckers, LLC Strongsville, Ohio  
[woodpeck.com](http://woodpeck.com)  
© 2021 Woodpeckers, LLC



**At Woodpeckers we are constantly reviewing & improving our tools. The most current version of our instruction manuals are always available to download/print at [woodpeck.com](http://woodpeck.com) via the tool's page.**  
*(Located in the bottom section of the tool page under the "Additional Information" or "Instructions" tabs.)*



**Be the first to know all the new products & sales by subscribing to our eClub.**  
*(Located at the top center of our webpage [woodpeck.com](http://woodpeck.com).)*



**Subscribe to our YouTube channel to stay up-to-date on all the latest tool tips & tricks.**



**Interact with us! Follow us on Facebook & Instagram!**



**WARNING!**

This product can expose you to chemicals, including chromium, which is known to the State of California to cause cancer and birth defects or other reproductive harm. For more information go to [www.P65Warnings.ca.gov](http://www.P65Warnings.ca.gov)