

Woodpeckers®

PRECISION TAPER JIG

OWNER'S MANUAL

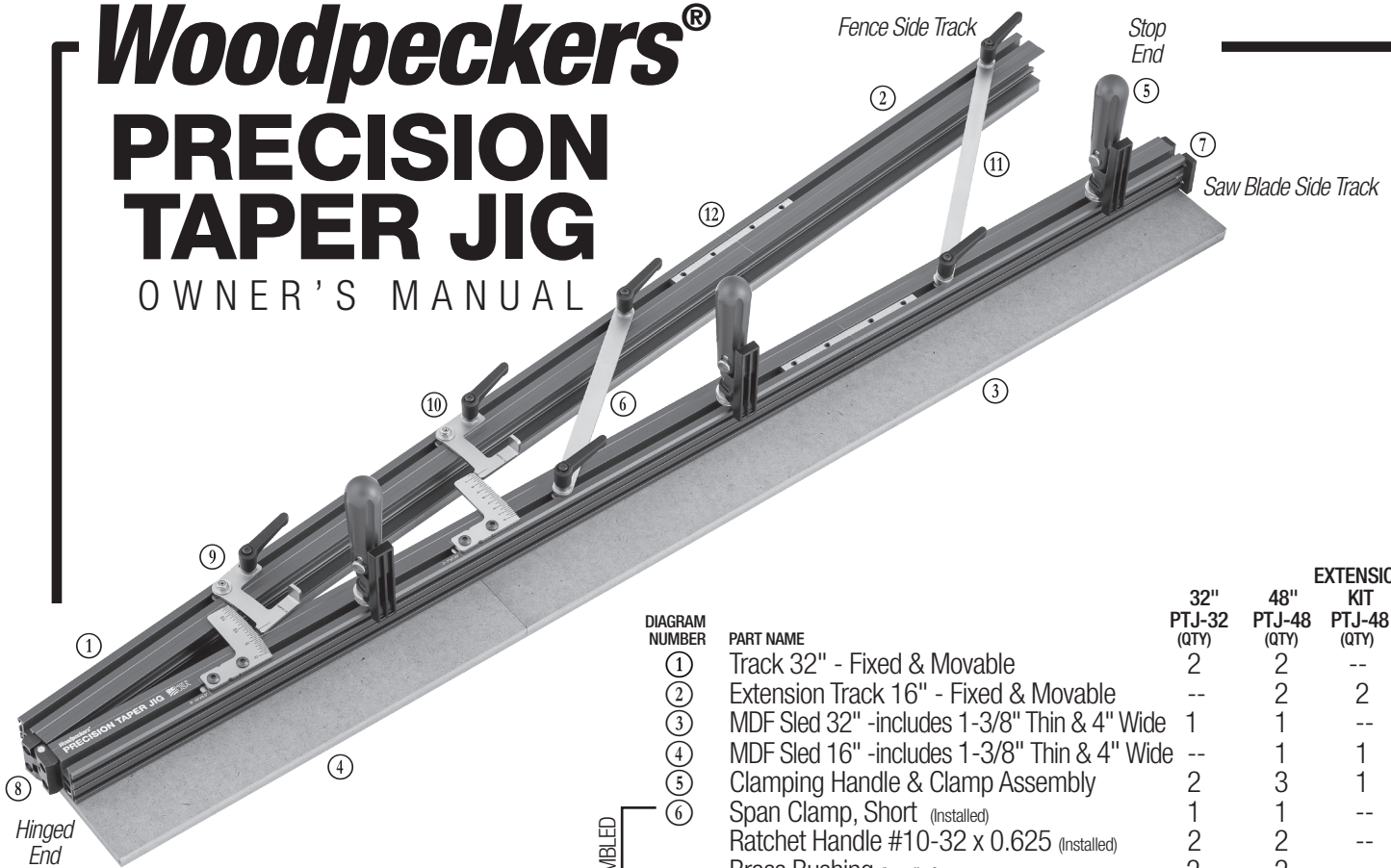

Precision Taper Jig 48"
Model Shown.

DIAGRAM NUMBER	PART NAME	EXTENSION KIT			
		32" PTJ-32 (QTY)	48" PTJ-48 (QTY)	PTJ-48 (QTY)	
①	Track 32" - Fixed & Movable	2	2	--	
②	Extension Track 16" - Fixed & Movable	--	2	2	
③	MDF Sled 32" -includes 1-3/8" Thin & 4" Wide	1	1	--	
④	MDF Sled 16" -includes 1-3/8" Thin & 4" Wide	--	1	1	
⑤	Clamping Handle & Clamp Assembly	2	3	1	
ASSEMBLED	⑥	Span Clamp, Short (Installed)	1	1	--
		Ratchet Handle #10-32 x 0.625 (Installed)	2	2	--
		Brass Bushing (Installed)	2	2	--
		Brass Shim (Installed)	2	2	--
		Oval Nut #10-32	2	2	--
	⑦	Push Plate (Installed)	1	1	--
	⑧	Hinge (Installed)	1	1	1
		Push Plate/Hinge Screw M4 x 0.7, 16mm (Installed)	7	10	3
	Hardware Kit A		1	2	1
		Screws 1/4"-20 (6)			
	Oval Nuts 1/4"-20 (6)				
Hardware Bag B		1	1	--	
⑨	Scale 0°-15° x 0.5° & Index Lock (1)				
⑩	Scale 0°-7° x 0.25° & Index Lock (1)				
	Ratchet Handle #10-32 x 0.625 (2)				
	Brass Bushing (4)				
	Brass Shim (8)				
	Button Head Cap Screw 1/4"-20 x 5/8" (4)				
	Thin Nylock Nut #10-32 (2)				
	Cone Point Set Screw #10-32 x 1" (2)				
	Oval Nut #10-32 (4)				
	Oval Nut 1/4"-20 (4)				
	Allen Key 5/32" (1)				
	Allen Key 3/32" (1)				
	Plastic Shim (2)				
Hardware Bag C		--	1	1	
ASSEMBLED	⑪	Span Clamp, Long (1)			
		Ratchet Handle #10-32 x 0.625 (2)			
		Brass Bushing (2)			
		Brass Shim (2)			
ASSEMBLED	⑫	Track Connector (2)			
		Set Screw 1/4"-20 x 1/2" (8)			
		Allen Key 1/8" (1)			

You will also need (not included)
Phillips Head Screwdriver



Scan the QR code above
to watch the video
or visit woodpeck.com
under the video tab towards
the bottom of the product page.

If you think you're missing anything, email us at mailroom@woodpeck.com.
You can also call us at 800-752-0725 from 9:00 a.m. to 4:00 p.m. EST Monday - Friday.

I. MDF SLED INSTALLATION

AT THIS POINT YOU WILL NEED:

- ① Track 32" - Fence Side & Saw Blade Side
- ③ MDF Sled 32" (If assembling a 32" Precision Taper Jig)

- | | |
|-----------|--|
| ASSEMBLED | <ul style="list-style-type: none"> • ⑥ Span Clamp, Short (Installed) • Ratchet Handle #10-32 x 0.625 (Installed) (2) • Brass Bushing (Installed) (2) • Brass Shim (Installed) (2) • Oval Nut #10-32 (2) |
| ASSEMBLED | <ul style="list-style-type: none"> • ⑦ Push Plate (Installed) • ⑧ Hinge (Installed) • Push Plate/Hinge Screw M4 x 0.7, 16mm (Installed) |

• HARDWARE BAG A

Screws 1/4"-20 (6)

Oval Nuts 1/4"-20 (6)

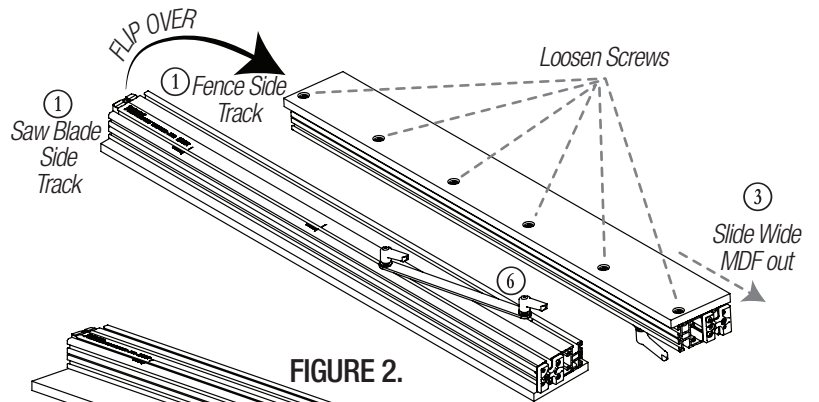

FIGURE 2.

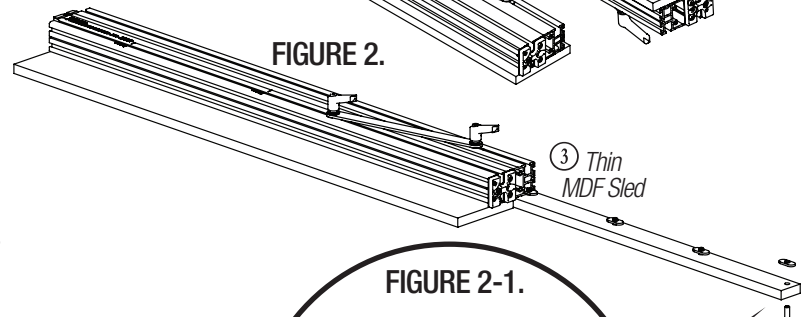

FIGURE 2-1.

NOTE: The Span Clamp ⑥ with the two Ratchet Handles comes pre-installed. Loosen both Ratchet Handles to allow the Precision Taper Jig Tracks ① to open and close.

NOTE: The Wide MDF Sled ③ is installed on the Fence Side Track of the Precision Taper Jig for shipping purposes. Flip the Precision Taper Jig over and loosen (do not remove) the (6) Screws on the Wide MDF Sled, then slide the Wide MDF Sled out of the Fence Side Track. **FIGURE 1.**

1. Place (6) Screws through the Thin MDF Sled ③ then thread the (6) Oval Nuts onto the end of each Screw. **FIGURE 2-1.**

NOTE: The holes for these Screws are intentionally tight. Thread the Screws into the holes with light pressure and continue to spin once the head bottoms out in the countersink.

2. Slide the Oval Nuts into the Fence Side Track. **FIGURE 2.**
3. Secure the (6) Screws into the countersunk holes on the Thin MDF Sled.
4. Slide the Wide MDF Sled's Oval Nuts into the Saw Blade Side Track.
5. Secure the (6) Screws in the countersunk holes on the Wide MDF Sled.
6. Your Precision Taper Jig should look like **FIGURE 3** at this point.

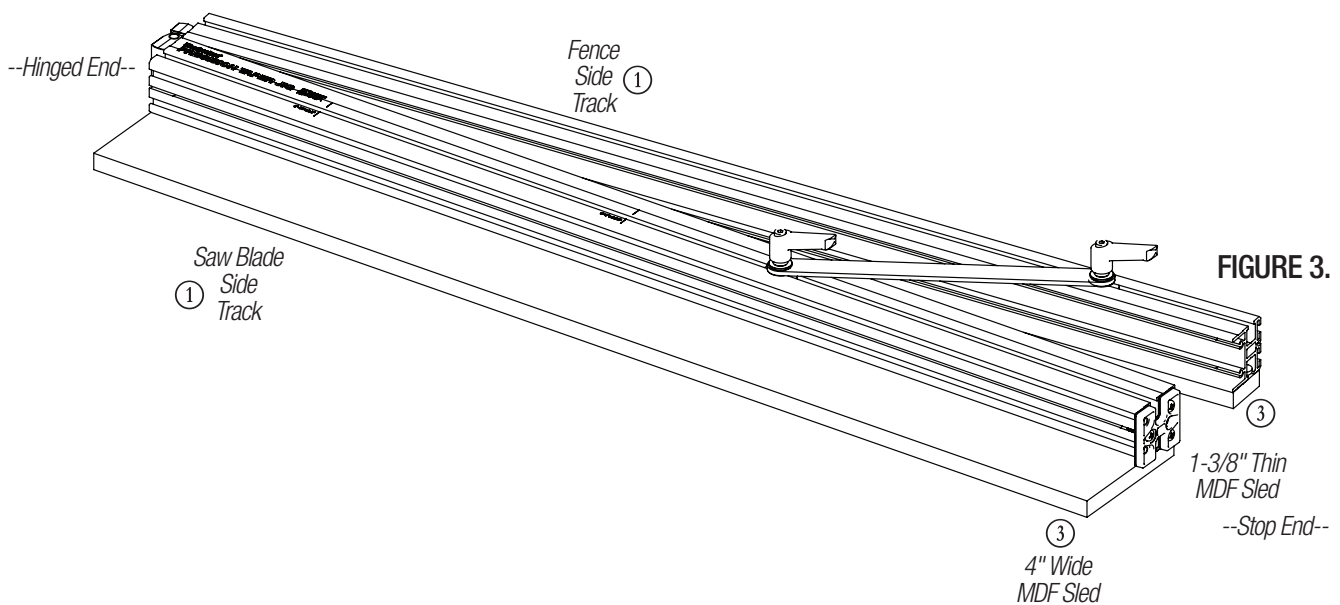

FIGURE 3.

II. SCALE INSTALLATION

AT THIS POINT YOU WILL NEED:

• HARDWARE BAG B

- ⑨ Scale 0°-15° x 0.5° & Index Lock
- ⑩ Scale 0°-7° x 0.25° & Index Lock
- Ratchet Handle #10-32 x 0.625 (2)
- Brass Bushing (4)
- Brass Shim (8)
- Button Head Cap Screw 1/4"-20 x 5/8" (4)
- Thin Nylock Nut #10-32 (2)
- Cone Point Set Screw #10-32 x 1" (2)
- Oval Nut #10-32 (4)
- Oval Nut 1/4"-20 (4)
- Allen Key 5/32"
- Allen Key 3/32"

NOTE: The Precision Taper Jig has two positive-locking angle scales. One adjusts from 0° to 7° in quarter-degree increments. The other adjusts from 0° to 15° in half-degree increments. Only one scale is needed at a time. You will probably want the 0° to 7° scale installed most of the time, unless your project calls for a larger angle. Both scales can remain installed at the same time, but having both on limits the range of motion you have for the Clamping Handles.

1. Remove the Span Clamp ⑥ from the Precision Taper Jig by loosening the two Ratchet Handles and sliding it out of the T-slot of the Track.
2. Pre-assemble the 0°-15° ⑨ or the 0°-7° ⑩ Scale & Index Lock following **FIGURE 4**.
3. Slide the Scale assembly into the Saw Blade Side Track, ensure that the Brass Shims span over the T-slot. **FIGURES 5 & 5-1**.
4. Slide the coordinating Index Lock assembly into the Fence Side Track, also ensuring the Brass Shims span over the T-slot.
5. Slide the paired-up Scale and Lock close to the corresponding laser engraved index mark on the Saw Blade Side Track. **NOTE:** Do not secure the Scales at this time. **FIGURE 6**.

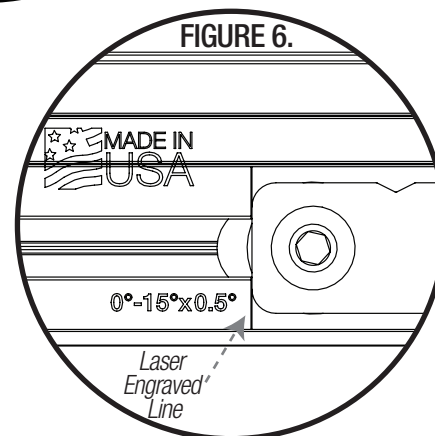
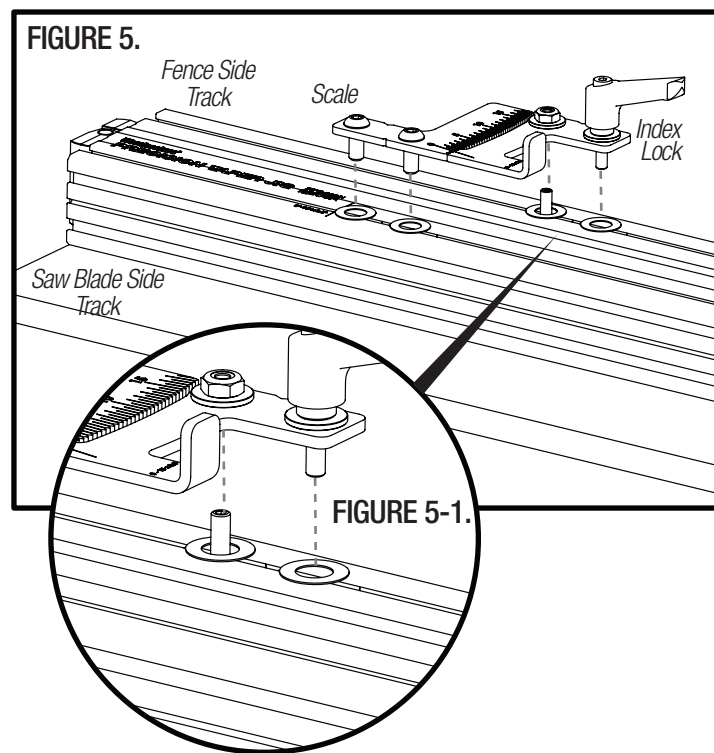
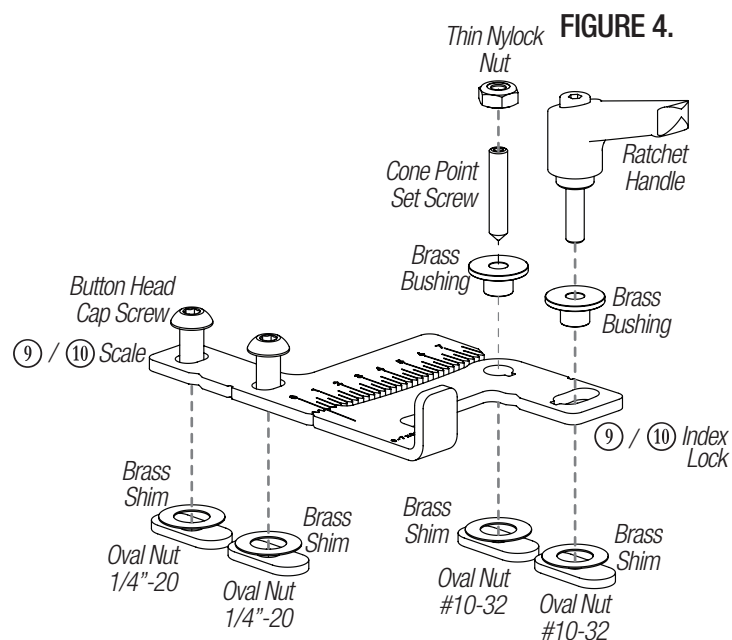

III. SCALE CALIBRATION

AT THIS POINT YOU WILL NEED:

- **HARDWARE BAG B**

Plastic Shim (2)

1. Loosen the Ratchet Handles on the Span Clamp and close the Precision Taper Jig to set to 0°.

2. Ensure that the gap between the Fence Side Track and Saw Blade Side Track at the Hinge End of the Precision Taper Jig matches the gap at the Stop End using the included Plastic Shims. **FIGURE 7.**

3. To set the gap at the Hinged End, loosen the Screws in one side of the Hinge ⑧, then squeeze the two Tracks together with the Plastic Shim in between. Re-tighten the Screws in the Hinge and the gap is now set. **FIGURE 7-1.**

4. Once the gap is made equal, lock down the Ratchet Handles on the Span Clamp to ensure the gap is maintained. You can remove the Plastic Shims.

5. With the Scale on its designated laser engraved line on the Saw Blade Side Track, (**FIGURE 6.**) set the Index Lock at "0". The Scale and Index Lock are to be parallel to the Saw Blade Side Track edge.

6. Secure the Scale by tightening the Button Head Cap Screws using the 5/32" Allen Key.

7. Secure the Index Lock by tightening the Ratchet Handles.

8. Tighten the Cone Point Set Screw with an 3/32" Allen Key. Tighten the Cone Point Set Screw so that it digs into the bottom of the Fence Side Track leaving an indentation. *This is intentional and provides you with a positive stop so that if the Scales are ever removed and reinstalled, recalibrating the Precision Taper Jig to the exact setting as before may be done.*

9. Tighten the Thin Nylock Nut on the Index Lock until it stops. The Cone Point Set Screw pivot should NOT be turning at all if properly installed.

10. Loosen the Ratchet Handle on the Index Lock and check for free movement. If the Index Lock is locked completely or too loose, adjust the Thin Nylock Nut to your personal preference.

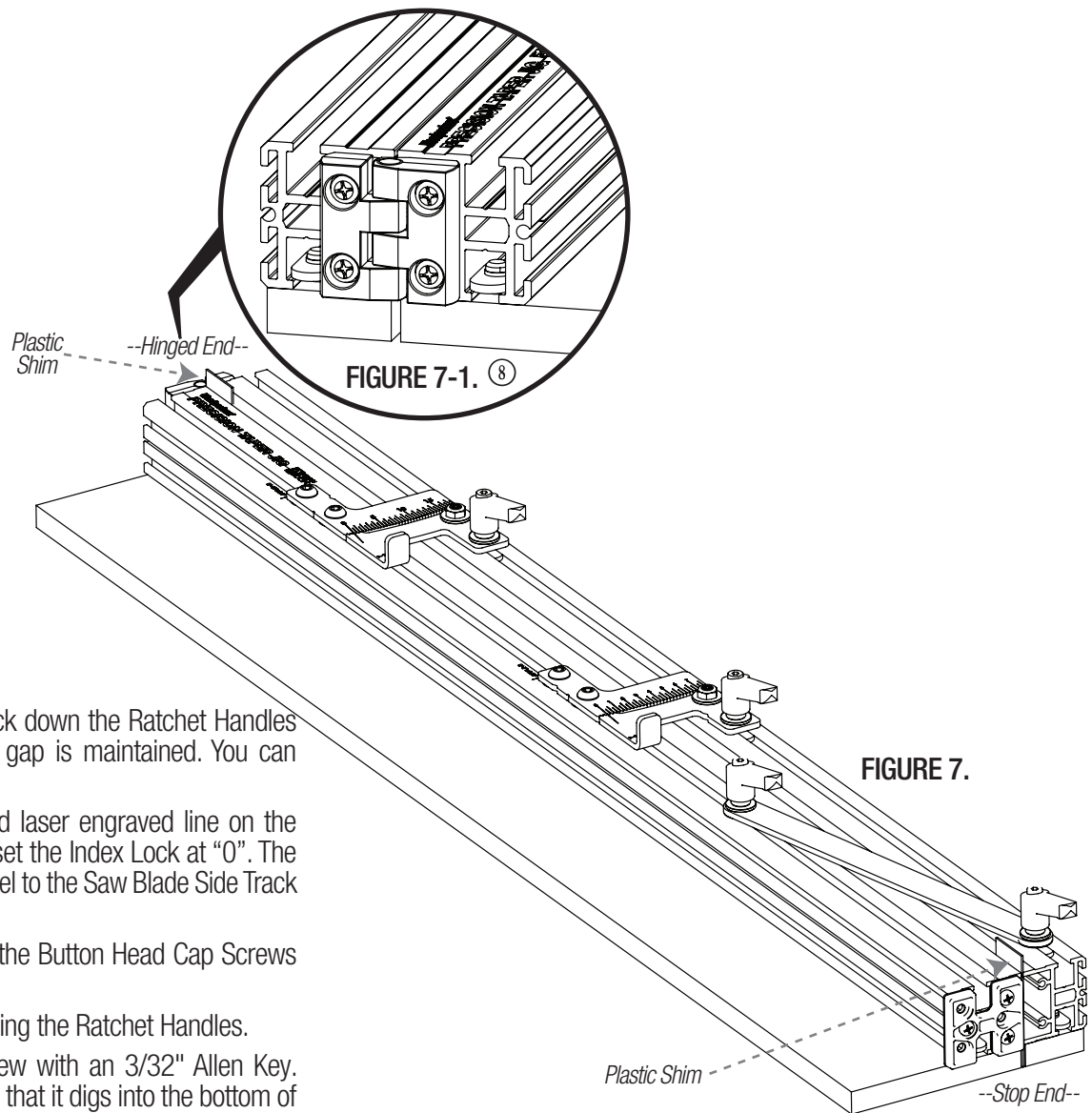

FIGURE 7.

IV. OPTIONAL EXTENSION KIT INSTALLATION

AT THIS POINT YOU WILL NEED:

- ② Extension Track 16" (2)
- ③ MDF Sled 16" -includes 1-3/8" Thin & 4" Wide
- ⑤ Clamping Handle & Clamp Assembly

• HARDWARE BAG C

- ⑪ Span Clamp, Long (1)
Ratchet Handle #10-32 x 0.625 (2)
Brass Bushing (2)
Brass Shim (2)
Oval Nut #10-32 (2)
- ⑫ Track Connector (2)
Set Screw 1/4"-20 x 1/2" (8)
Allen Key 1/8" (1)

• HARDWARE BAG A

- Screws 1/4"-20 (6)
- Oval Nuts 1/4"-20 (6)

1. Remove the Push Plate ⑦ from the end of the Saw Blade Side Track. **FIGURE 8.**

2. Loosen (do not remove) the Screws securing both MDF Sleds. Slide the MDF Sleds out away from the hinged side of the Precision Taper Jig so that roughly 16" of the MDF Sled is exposed. **FIGURE 9.**

3. Locate the 16" Extension Tracks ②. One end of the Extension Track will have 3 Screws installed where the Push Plate is to be installed. This Extension Track will attach to the left side of the Precision Taper Jig.

4. Starting with the Saw Blade Side Track side, install a Track Connector and the Set Screws for it. Then, slide the Extension Track over the exposed Oval Nuts of the 32" long Sled, until the Extension Track touches the 32" Track. **FIGURE 10 & 10-A.**

5. The Track Connector can then be adjusted so that it is evenly distributed between the 32" and 16" Tracks. Repeat for the fixed side 32" and 16" Extension Tracks.

6. Secure the Track Connectors with Set Screws using an 1/8" Allen Key.

7. On the underside of the now 48" long taper jig, ensure that the 32" long sleds are even with the end of the tracks, then tighten the screws.

8. In the 16" MDF extension sleds, install the Countersunk Screws and Oval Nuts (as in Section I. Page 2). Slide these Extension Sleds in from the Hinge end until they contact the 32" Long Sleds. Tighten the Screws. **FIGURE 11.**

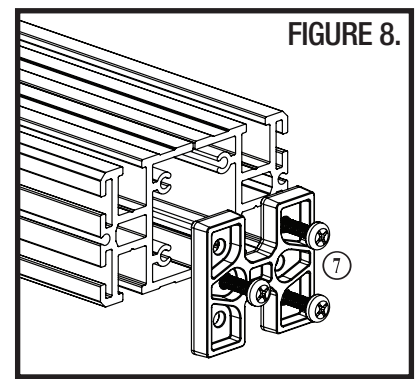

FIGURE 8.

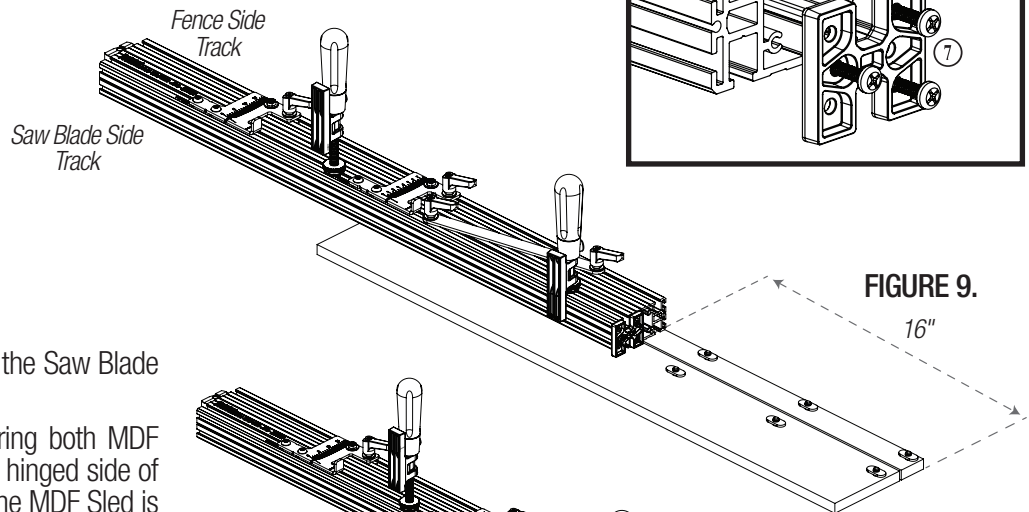

FIGURE 9.

16"

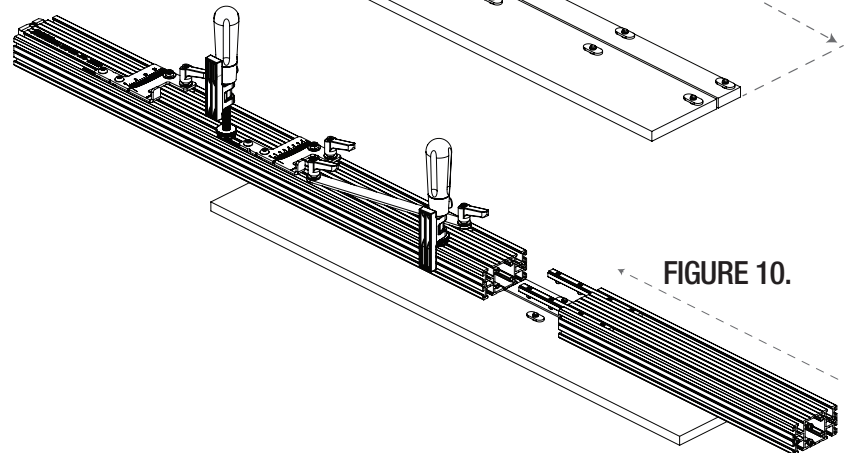

FIGURE 10.

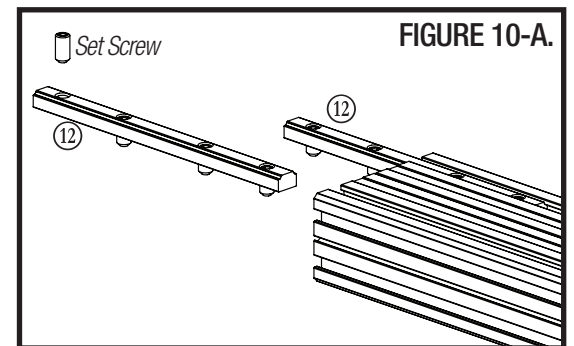

FIGURE 10-A.

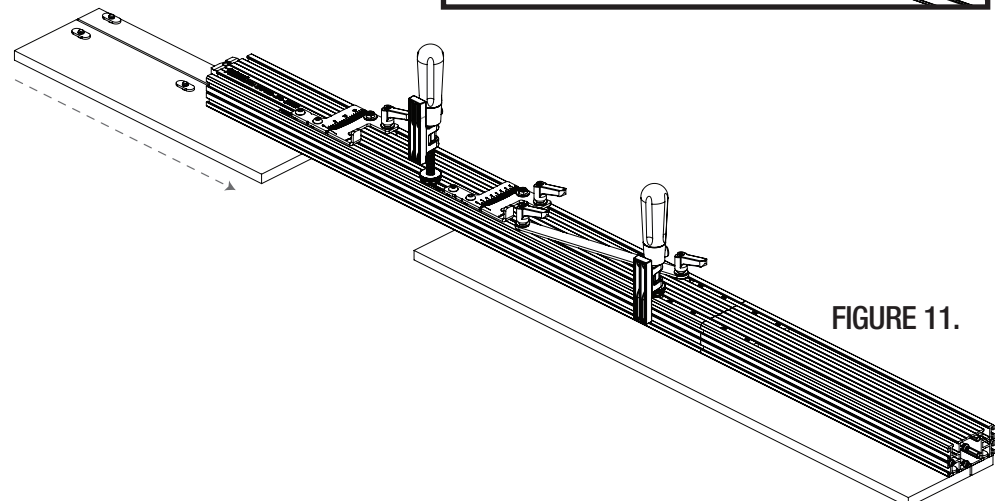

FIGURE 11.

9. Assemble the Long Span Clamp ⑪. **FIGURE 12.**
10. Install the Long Span Clamp into the Extension Track ensuring the Brass Shims are spanning the T-slot.
11. Slide the additional Clamping Handle ⑤ Clamping Stud into the Saw Blade Side Track from the end.
12. To secure the Clamping Handle, tighten the Brass Thumb Knob on the Clamping Stud.
13. Install the Push Plate ⑦ in the end of the Saw Blade Side Track. **FIGURE 8.**
14. When complete, your Precision Taper Jig should now be 48" long. **FIGURE 13.**



FIGURE 12.

Brass Bushing

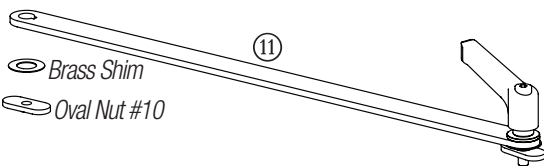

Brass Shim

Oval Nut #10

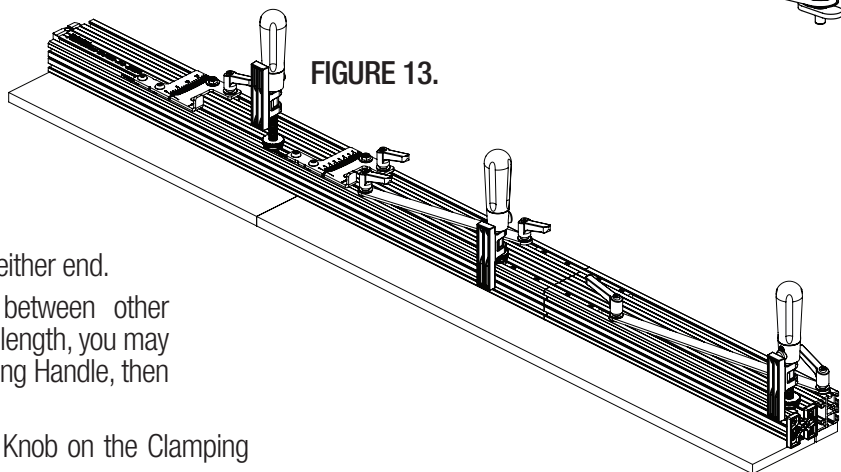

FIGURE 13.

V. CLAMPING HANDLE INSTALLATION AT THIS POINT YOU WILL NEED:

- ⑤ Clamping Handle & Clamp Assembly

1. Slide the Clamping Stud into the Saw Blade Side Track from either end.
NOTE: The Clamping Handle may become “trapped” between other components of the Precision Taper Jig. Based on work piece length, you may want to remove the Span Clamp temporarily, install a Clamping Handle, then reinstall the Span Clamp.
2. To secure the Clamping Handles, tighten the Brass Thumb Knob on the Clamping Stud. **FIGURE 14.**

VI. QUICK ADJUST CLAMPING HANDLE OPERATION

1. Push the Release Button on the Clamping Handle and lift up or slide down for quick position changes.
2. The Clamping Dogs can be reversed from the UP or DOWN position to support a clamping range from 3" down to 17/32". Smaller workpieces may require a simple wooden spacer. **FIGURE 15.**

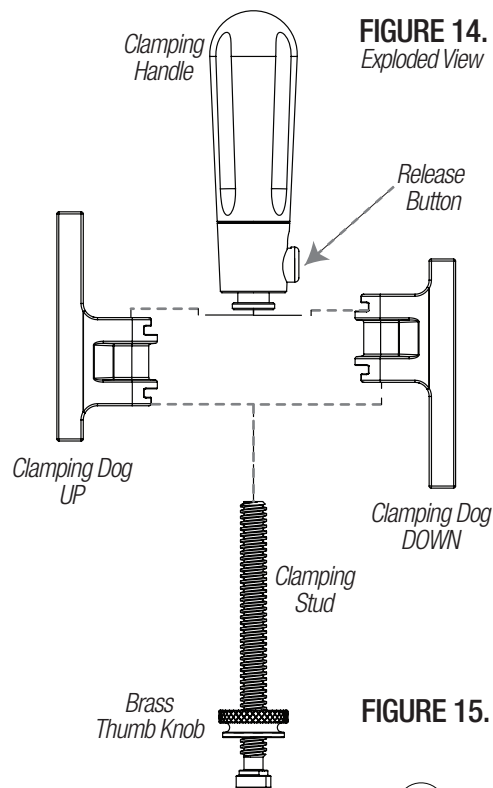

FIGURE 14.
Exploded View

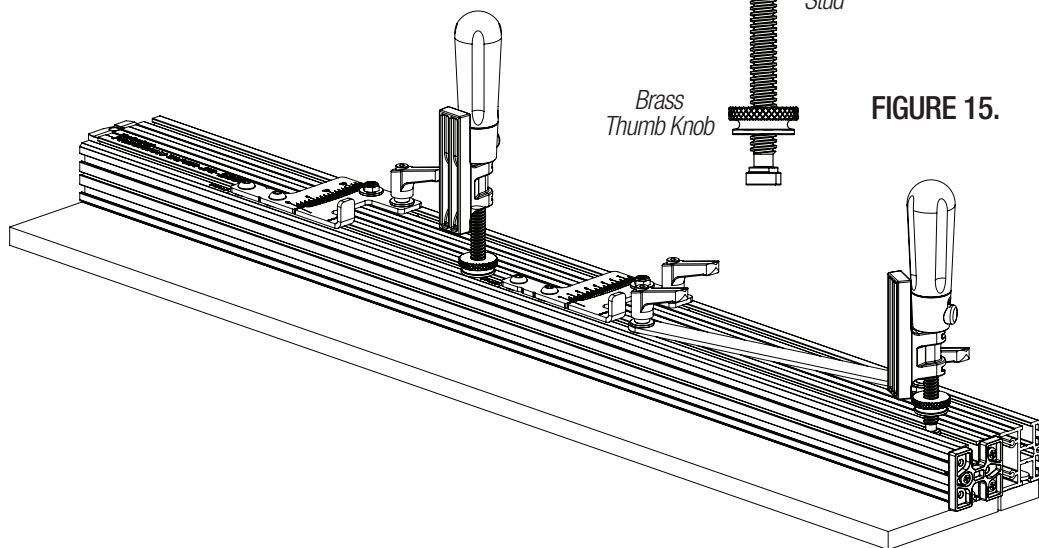

FIGURE 15.

VII. CUTTING TAPERS WITH THE MDF SLEDS INSTALLED

1. Set the Precision Taper Jig to 0°.
2. Place your workpiece on the Wide MDF Sled.
3. Press the right side of the workpiece against the fence of the Precision Taper Jig.
4. Make a pencil mark at the front of the MDF Sled where the left side of the workpiece ends.

FIGURE 16.

5. Remove the workpiece and cut off the excess MDF Sled where you made your pencil mark.

6. Mark your workpiece where you would like the taper to begin.

7. Set the desired angle of the Precision Taper Jig with the Scale and lock. Then tighten the Ratchet Handles on the Span Clamp.

8. Place the workpiece back on the Wide MDF Sled ensuring that the end is pressed firmly up against the Push Plate.

9. Use the Clamping Handles to clamp the workpiece in place.

10. With the right side of the Precision Taper Jig pressed firmly up against your table saw rip-fence, slide the fence over until your taper starting point kisses your table saw blade.

11. Lock your table saw rip-fence in place.

12. Slide the Precision Taper Jig back so that the workpiece is no longer contacting the blade.

FIGURE 19.

13. Turn the table saw on.

14. Using the Clamping Handles as gripping points, push the MDF Sled through the blade.

15. Ensure that the right side of the Precision Taper Jig maintains contact with your table saw rip-fence.

VIII. CUTTING TAPERS WITHOUT MDF SLEDS.

- If your workpiece is wider than the MDF Sled it may be easier to make the cut without the MDF Sleds installed.
- To remove the MDF Sled, flip the Precision Taper Jig over and loosen the Phillips head screws on the Thin and Wide MDF Sled. Remove the MDF Sleds by sliding them out of the Track.

NOTE: Clamping Handles cannot be used as clamps without the MDF Sleds installed. They still may be used as gripping points to push the sled.

- You may create your own wider sled to replace the standard 4" Wide MDF Sled to accommodate your workpiece.

IX. REPLACEMENT PARTS

If you would like replacement parts for the Push Plate, Clamping Dogs, or MDF Sleds, they are available at woodpeck.com.

NOTE: If the Push Plate gets nicked or damaged during operation, it may be rotated one time to get an additional clean stop.

FIGURE 16.

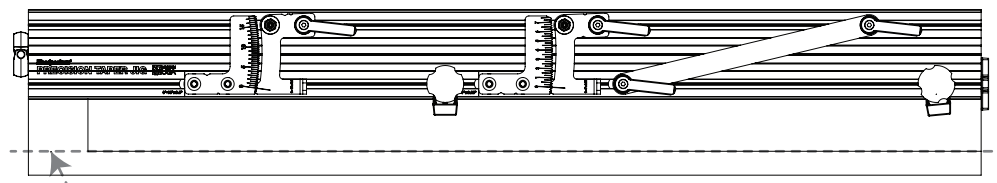

Mark the edge where the taper will start then rip off the excess MDF Sled, with MDF Sled at 0° setting.

FIGURE 17.

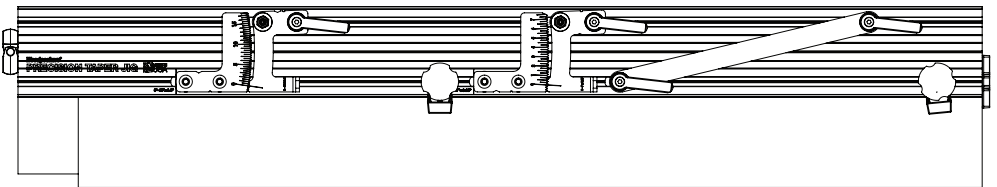

If the part to be cut hangs off the MDF Sled slightly, you don't need to pre-cut the MDF Sled to width.
NOTE: If your part hangs off the edge of the MDF Sled, you may see tear out on part of your finished piece.

FIGURE 18.

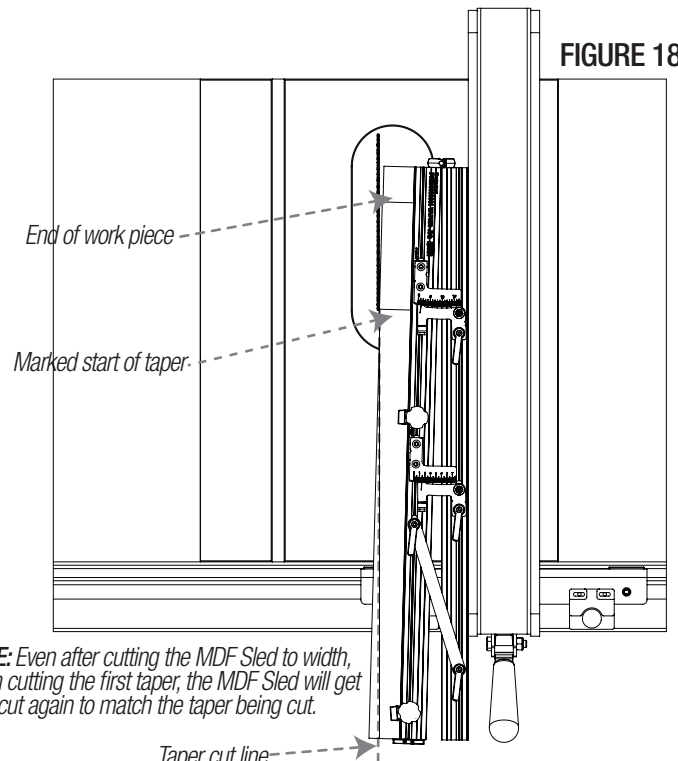

NOTE: Even after cutting the MDF Sled to width, When cutting the first taper, the MDF Sled will get cut again to match the taper being cut.

FIGURE 19.

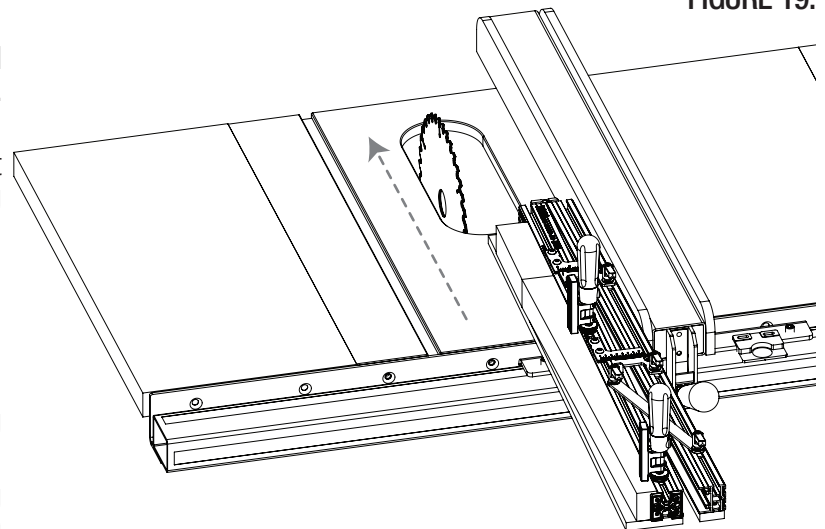

X. ANGLE CONVERSION CHART

Use these charts to help you precisely plan your precision taper.

Fractional Taper Per Inch (Inches per inch)	Decimal Taper Per Inch (Inches per inch)	Angle Degrees
1/32	0.031	1.79°
1/16	0.063	3.58°
3/32	0.094	5.36°
1/8	0.125	7.13°
5/32	0.156	8.88°
3/16	0.188	10.62°
7/32	0.219	12.34°
1/4	0.250	14.04°
9/32	0.281	15.71°

Fractional Taper Per Foot (Inches per foot)	Decimal Taper Per Foot (Inches per foot)	Angle Degrees
1/32	0.031	0.15°
1/16	0.063	0.30°
3/32	0.094	0.45°
1/8	0.125	0.60°
5/32	0.156	0.75°
3/16	0.188	0.90°
7/32	0.219	1.04°
1/4	0.250	1.19°
9/32	0.281	1.34°
5/16	0.313	1.49°
11/32	0.344	1.64°
3/8	0.375	1.79°
13/32	0.406	1.94°
7/16	0.438	2.09°
15/32	0.469	2.24°
1/2	0.500	2.39°
17/32	0.531	2.53°
9/16	0.563	2.68°
19/32	0.594	2.83°
5/8	0.625	2.98°
21/32	0.656	3.13°
11/16	0.688	3.28°
23/32	0.719	3.43°
3/4	0.750	3.58°
25/32	0.781	3.72°
13/16	0.813	3.87°
27/32	0.844	4.02°
7/8	0.875	4.17°
29/32	0.906	4.32°
15/16	0.938	4.47°
31/32	0.969	4.62°
1	1	4.76°

Angle Degrees	Taper Per Inch (Inches per foot)	Taper Per Foot (Inches per foot)	Angle Degrees	Taper Per Inch (Inches per foot)	Taper Per Foot (Inches per foot)
0.00°	0.000	0.000	6.00°	0.105	1.261
0.25°	0.004	0.052	6.25°	0.110	1.314
0.50°	0.009	0.105	6.50°	0.114	1.367
0.75°	0.013	0.157	6.75°	0.118	1.420
1.00°	0.017	0.209	7.00°	0.123	1.473
1.25°	0.022	0.262	7.25°	0.127	1.527
1.50°	0.026	0.314	7.50°	0.132	1.580
1.75°	0.031	0.367	8.00°	0.141	1.686
2.00°	0.035	0.419	8.50°	0.149	1.793
2.25°	0.039	0.471	9.00°	0.158	1.901
2.50°	0.044	0.524	9.50°	0.167	2.008
2.75°	0.048	0.576	10.00°	0.176	2.116
3.00°	0.052	0.629	10.50°	0.185	2.224
3.25°	0.057	0.681	11.00°	0.194	2.333
3.50°	0.061	0.734	11.50°	0.203	2.441
3.75°	0.066	0.787	12.00°	0.213	2.551
4.00°	0.070	0.839	12.50°	0.222	2.660
4.25°	0.074	0.892	13.00°	0.231	2.770
4.50°	0.079	0.944	13.50°	0.240	2.881
4.75°	0.083	0.997	14.00°	0.249	2.992
5.00°	0.087	1.050	14.50°	0.259	3.103
5.25°	0.092	1.103	15.00°	0.268	3.215
5.50°	0.096	1.155	15.50°	0.277	3.328
5.75°	0.101	1.208	16.00°	0.287	3.441



If you would like to learn how to cut three different styles of tapers using the Precision Taper Jig, scan this QR code to watch a YouTube Video or visit Woodpeck.com and search Precision Taper Jig .



WARNING! To reduce the risk of injury, always use featherboards, push sticks or push blocks with proper guarding. Keep hands away from moving parts. Refer to your saw manual for proper setup and use.



WARNING! To reduce the risk of injury, wear safety goggles or glasses with side shields, ear protection & a dust mask.

Woodpeckers®

Woodpeckers, LLC Strongsville, Ohio
woodpeck.com
 © 2023 Woodpeckers, LLC



At Woodpeckers we are constantly reviewing & improving our tools. The most current version of our instruction manuals are always available to download at woodpeck.com.
 (Located in the bottom section of the tool's page under the "Additional Information" or "Instructions" tabs.)



Be the first to know all the new products, **OneTIME Tools & sales** by subscribing to our eClub. (Located at the top center of our webpage woodpeck.com.)



Subscribe to our YouTube channel to stay up-to-date on all the latest tool tips & tricks.



INTERACT WITH US! Follow us on Facebook, Instagram & TikTok!



Enjoy shop tips, project ideas, tool techniques & more in our Woodworking Resource Center/Blog. (Located at the bottom center of our webpage woodpeck.com.)



WARNING!
 This product can expose you to chemicals, including chromium, which is known to the State of California to cause cancer and birth defects or other reproductive harm. For more information go to www.P65Warnings.ca.gov