

Woodpeckers®

SLAB FLATTENING MILL

O W N E R ' S M A N U A L

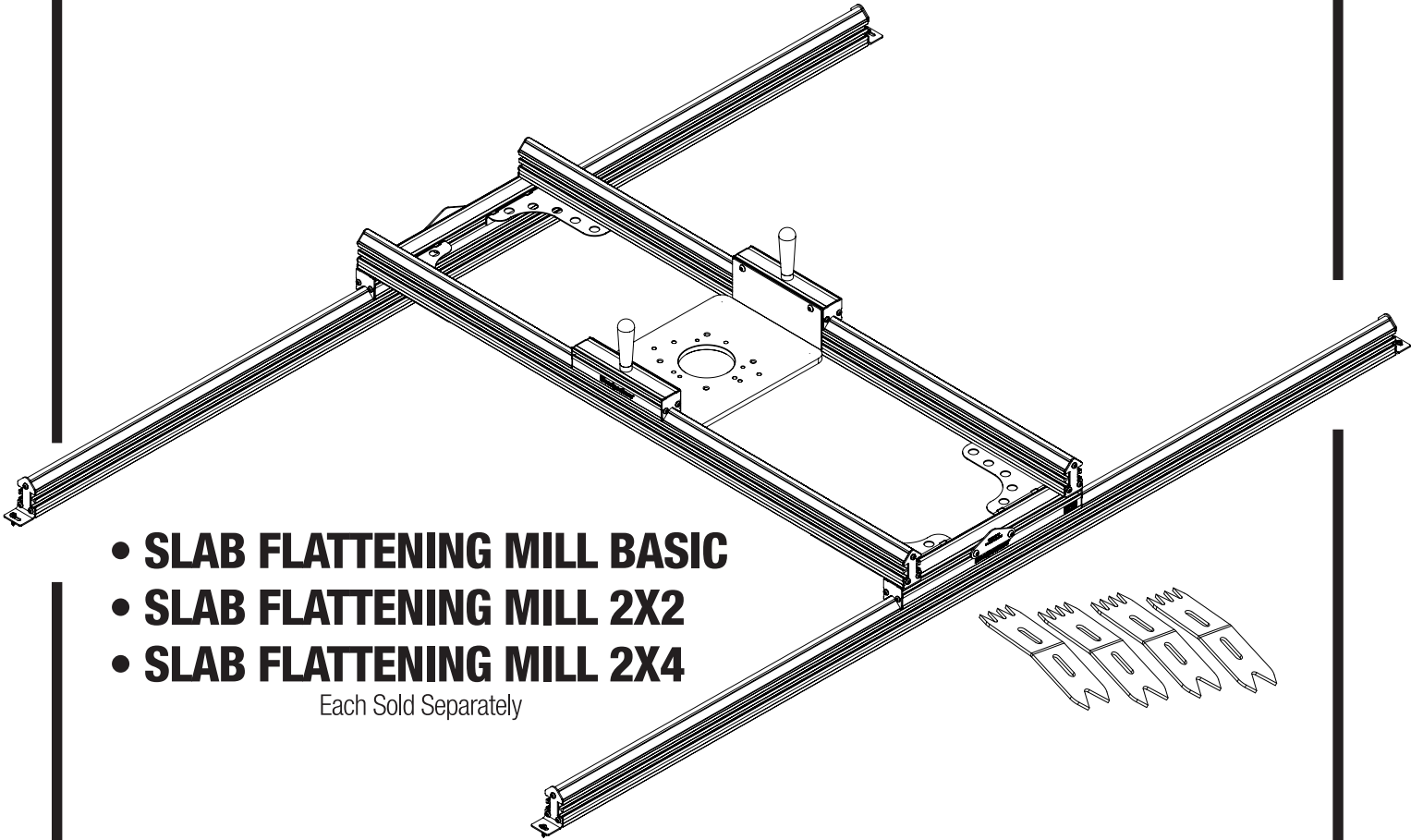

- **SLAB FLATTENING MILL BASIC**
- **SLAB FLATTENING MILL 2X2**
- **SLAB FLATTENING MILL 2X4**

Each Sold Separately

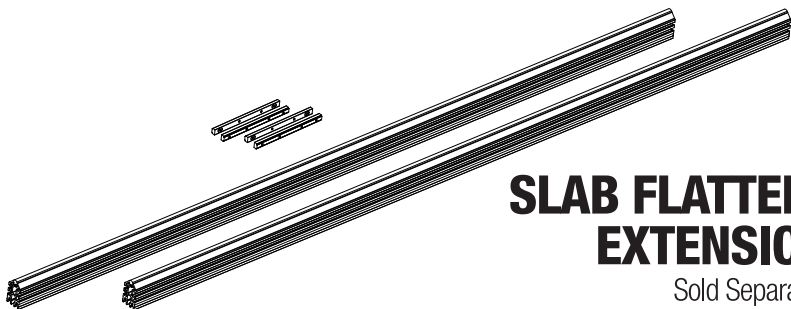
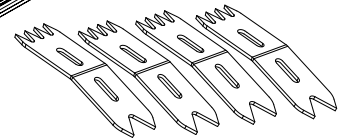

SLAB FLATTENING MILL EXTENSION KIT

Sold Separately



Scan the QR code above
to watch the video
or visit woodpeck.com
under the video tab towards
the bottom of the product page.

If you think you're missing anything, email us at mailroom@woodpeck.com.
You can also call us at 800-752-0725 from 9:00 a.m. to 4:00 p.m. EST Monday - Friday.

ITEM NO.	DESCRIPTION	QTY.
①	Short V-Rail <i>See chart below</i>	2
②	Long V-Rail <i>See chart below</i> <i>(4) V-Rails & (4) V-Rail Connectors included Extended Slab Flattening Mill</i>	2
③	Short Guide Block	2
④	Long Guide Block	2
⑤	Router Plate	1
⑥	Router Plate Hanger	2
⑦	V-Rail End Cap	4
⑧	V-Rail Mounting End Cap	4
⑨	Guide Block End Cap	8
⑩	Gusset Right	2
⑪	Gusset Left	2

Hardware Bag A		
⑫	Button Head Hex Screw 1/4"-20 x 1/2"	8
⑬	Track Nut 1/4"-20	16
⑭	Button Head Cap Screw 1/4"-20 x 1	8

Hardware Bag B		
⑮	Button Head Hex Screw 1/4"-20 x 1-1/2"	4
⑯	Lock Nut 1/4"-20	4

Hardware Bag C		
⑰	Safety Stop	2
⑱	Button Head Hex Screw 1/4"-20 x 5/8"	4
⑲	Lock Nut 1/4"-20	4

Hardware Bag D		
⑳	Thread Forming Screw Pan Head 10-32 x 1/2"	40
N/A	T25 Torx Bit - <i>For use with all torx screws</i>	1
N/A	5/32" Hex Key - <i>For use with all hex screws</i>	1

ITEM NO.	DESCRIPTION	QTY.
Hardware Bag E		
㉑	Pan Head Screw #10 x 3/4"	4
Hardware Bag F		
㉒	Tapered Handle	2
㉓	Black Nylon Washer	2
㉔	Hex Head Bolt 1/4"-20 x 1-1/2"	2
Hardware Bag G		
㉕	Button Head Hex Screw 1/4"-20 x 5/8"	4
㉖	Lock Nut 1/4"-20	4
Hardware Bag H		
㉗	Pan Head Screw 10-32 x 3/8"; <i>black</i>	4
㉗B	#10 Washer SAE	4
㉘	Roll of UHMW Tape	1
㉙	Track Connectors <i>Track Connectors included in Extended Slab Flattening Mill & Extension Kit Only</i>	4
㉚	Slab Clamping Dogs <i>Screws Not Provided</i>	4

Hardware Bag I - Router Screws <i>See page 6 for Router Chart</i>	
5/16"-18 (4), 1/4"-20 (4), 10-24 (3), 8-32 (3), M6 x 1.00" (3), M4 x 0.7" (3)	

Slab Flattening Mill Size	V-Rail Lengths	Maximum Slab Size
2' x 2'	33.25" x 39.5"	24" x 24"
2' x 4'	33.25" x 64"	24" x 48"
Basic	48" x 72"	38.75" x 56.5"
Extended (Configuration #1)	48" x 144"	38.725" x 128.5"
Extended (Configuration #2)	72" x 120"	62.75" x 104.5"

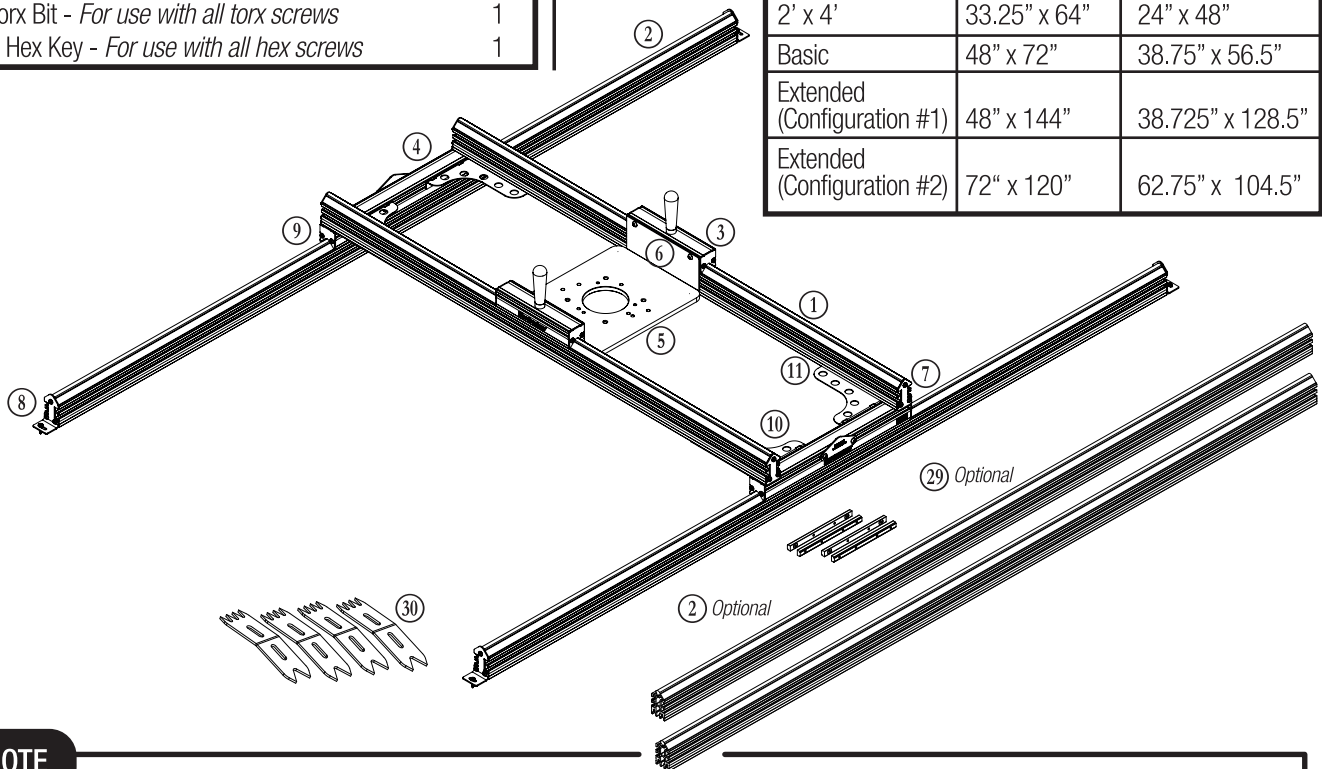

IMPORTANT NOTE

To deliver the most accurate results, your Slab Flattening Mill needs to be mounted to a surface that is well supported and flat in both directions. We recommend using a sheet of quality hardwood plywood or medium density fiberboard (MDF) resting on a workbench that supports the sheet nearly to its edges. Using a smaller bench, you can build a frame that extends support for the sheet. To verify that your surface is flat, adjust your workbench legs with shims so that the top is level in both directions, then check the worksurface with a straight edge. Once you have the surface both level and flat, you're ready to assemble your Slab Flattening Mill. Begin by assembling the Carriage Assembly.

REMOVE THE FOLLOWING TOOLS FROM HARDWARE BAG D

- T25 Torx Bit - For use with all torx screws
- 5/32" Hex Key - For use with all hex screws

I. AT THIS POINT YOU WILL NEED:

- ③ Short Guide Blocks, *one hole* (2)
- ④ Long Guide Blocks, *two hole* (2)
- ⑳ Roll of UHMW Tape

1. Cut eight 4" long strips from the roll of UHMW Tape. Peel off the backing and apply the strips to the two Long Guide Blocks. **Figure 1.** Align the long edge of the UHMW Tape with the edge of the groove as shown below in detail **1-A.** Align the end of the UHMW Tape with the end of the Guide Blocks as shown below in detail **1-B.**

2. Cut eight 2" long strips from the roll of UHMW Tape. Peel off the backing and apply the strips to the two Short Guide Blocks, **Figure 1.** Align the long edge of the UHMW Tape with the edge of the groove as shown below in detail **1-A.** Align the end of the UHMW Tape with the end of the Guide Blocks as shown below in detail **1-B.**

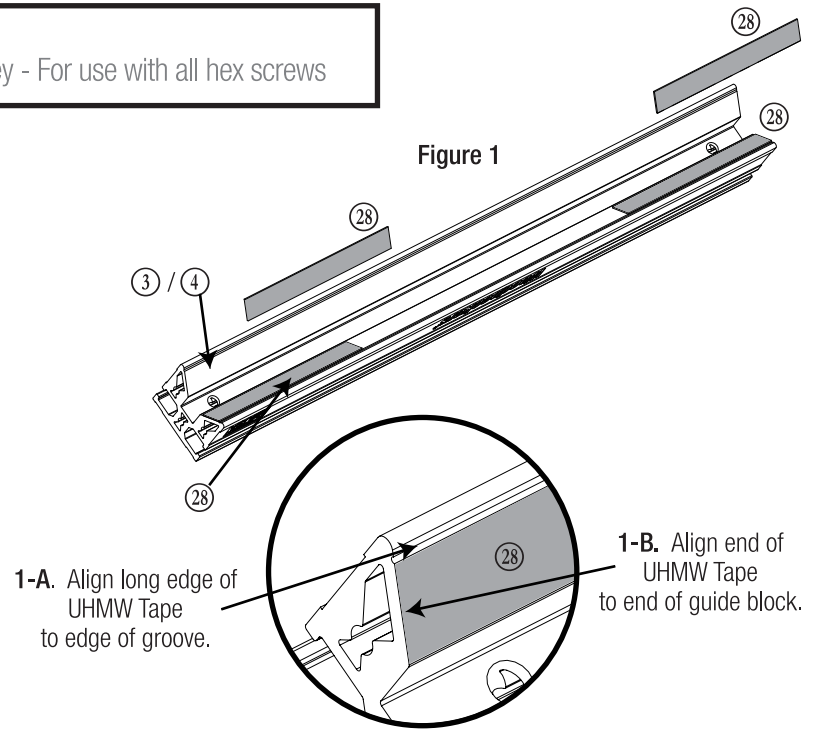

II. AT THIS POINT YOU WILL NEED:

- ⑩ Gusset Right (2)
- ⑪ Gusset Left (2)
- **HARDWARE BAG A**
 - ⑫ Button Head Hex Screw 1/4"-20 x 1/2" (8)
 - ⑬ Track Nut 1/4"-20 (16)
 - ⑭ Button Head Cap Screw 1/4"-20 x 1" (8)

3. Loosely install two Button Head Hex Screws and two Track Nuts in the folded edge of the four Gussets with the Track Nuts on the outside of the Gusset. **Figure 2.**

4. Loosely install two Button Head Cap Screws and two Track Nuts in the large flat section of the four Gussets with the Track Nuts on the side opposite the folded edge. **Figure 2.**

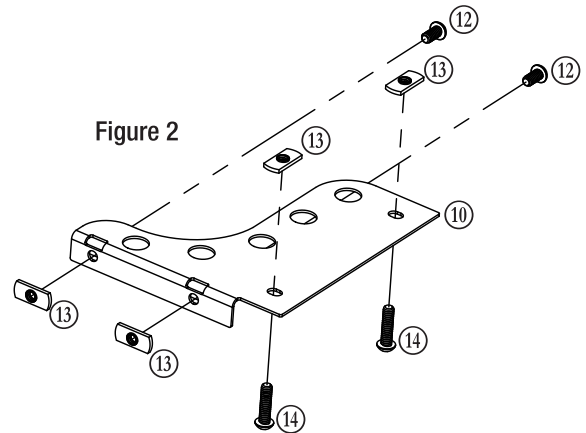

III. AT THIS POINT YOU WILL NEED:

- ④ Long Guide Block (2)
- **HARDWARE BAG B**
 - ⑮ Button Head Hex Screw 1/4"-20 x 1-1/2" (4)
 - ⑯ Lock Nut 1/4"-20 (4)

5. Mount the Gusset Assemblies to the Long Guide Blocks by sliding the Track Nuts located in the folded edge of the Gusset into the track on the Guide Blocks Long. **Figure 3.**

NOTE: There is a Right Gusset Assembly and Left Gusset Assembly for each Long Guide Block.

6. Install a Button Head Hex Screw and a Lock Nut in all four ends of the Long Guide Blocks. **Figure 3.**

7. Carriage End Assemblies should look like the fully assembled drawing in **Figure 4.** **DO NOT tighten bolts at this time.**

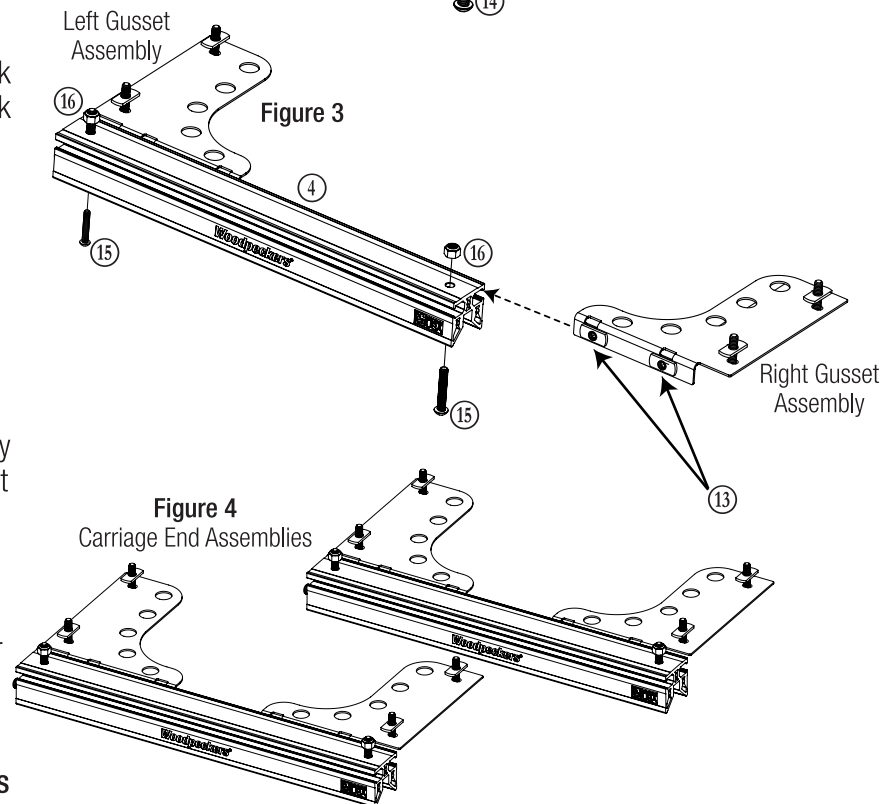

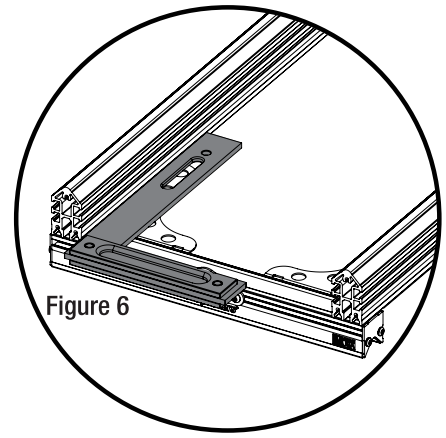
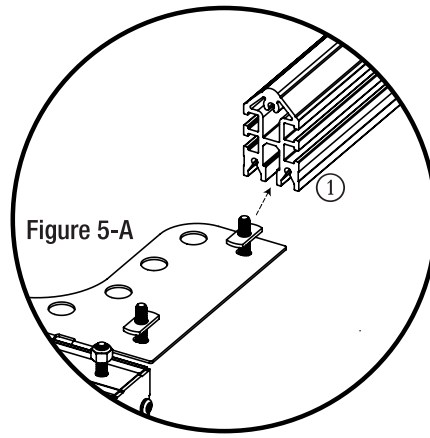
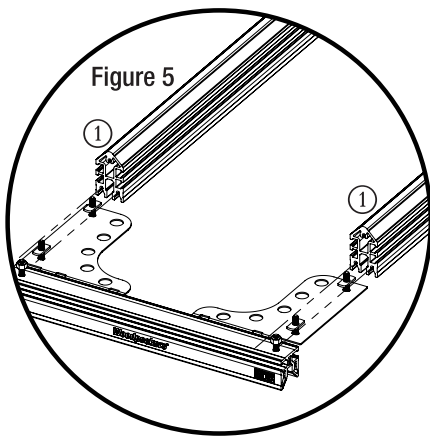

IV. AT THIS POINT YOU WILL NEED:

- ① Short V-Rails (2)

8. Slide the Carriage End Assemblies into both ends of both Short V-Rails with the Track Nuts and Lock Nuts of the Carriage End Assemblies sliding into the bottom groove of the V-Rails. **Figure 5/5-A.** Align the ends of the Short V-Rails with the outside surface of the Long Guide Blocks.

9. Square each corner with an accurate square and lock the Bolts. **Figure 6.**

NOTE: If working with a narrower slab, you can slide either end in to the appropriate width. Always check the assembly with a square when making adjustments.

V. AT THIS POINT YOU WILL NEED:

- **HARDWARE BAG C**
 - ⑰ Safety Stop (2)
 - ⑱ Button Head Hex Screw 1/4"-20 x 5/8" (4)
 - ⑲ Lock Nut 1/4"-20 (4)

10. Install the Safety Stops to both ends of the Carriage Assembly with two Button Head Hex Screws and two Lock Nuts. Position both Safety Stops at the center of the Long Guide Blocks. **Figure 7.** The Safety Stops prevent you from running your router bit into the Guide Blocks. **DO NOT LEAVE THESE OFF!**

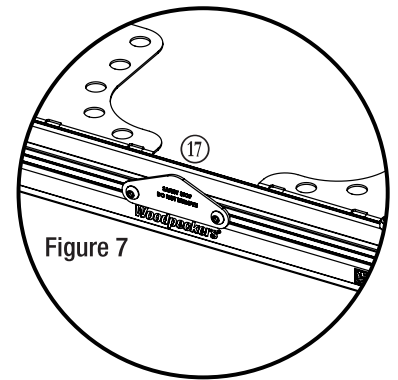

VI. AT THIS POINT YOU WILL NEED:

- ⑧ V-Rail Mounting End Cap (4)
- ② Long V-Rail (2)
- **HARDWARE BAG D**
 - ⑳ Thread Forming Screw Pan Head 10-32 x 1/2" (12)
- **HARDWARE BAG E**
 - ㉑ Pan Head Screw #10 x 3/4" (4)

11. Install the V-Rail Mounting End Caps to both ends of two Long V-Rails using 3 Thread Forming Screws. **Figure 8/8-A.** Use a handheld screwdriver to install the thread forming screws. **NOTE: It is very easy to strip out the aluminum extrusion if you use a power driver.**

12. Install one Long V-Rail Assembly along one edge of your work surface using Pan Head Screws through the V-Rail Mounting End Caps. **Figure 9.**

13. Based on the width of the slab you're going to mill, cut a piece of scrap stock to your slab width dimension, plus 7". Use the stock as a gauge block to position the second Long V-Rail parallel to the installed V-Rail. To simply set up for maximum width, make your gauge block 45". **Figure 10.**

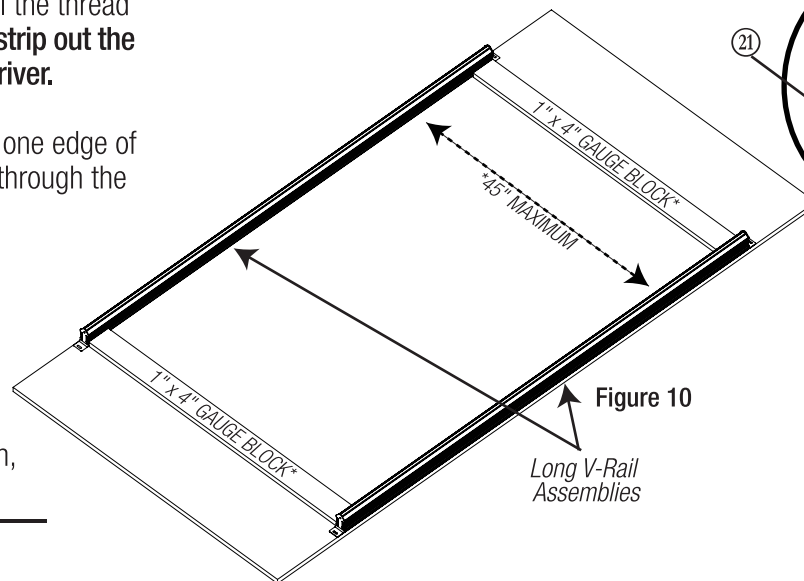
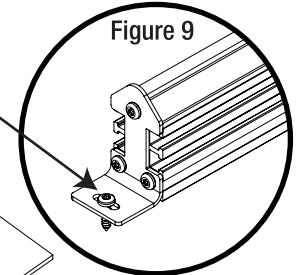
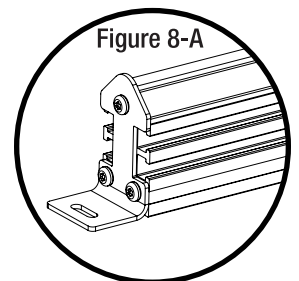
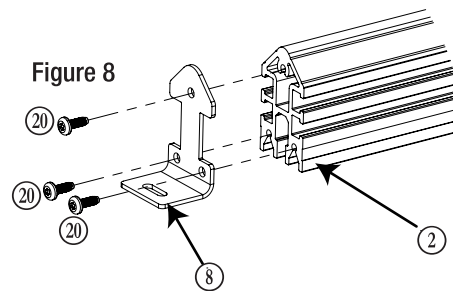

VII. AT THIS POINT YOU WILL NEED:

- ③ Short Guide Block (2)
- ⑥ Router Plate Hanger (2)
- **HARDWARE BAG F**
 - ② Tapered Handle (2)
 - ③ Black Nylon Washer (2)
 - ④ Hex Head Bolt 1/4"-20 x 1-1/2" (2)
- **HARDWARE BAG G**
 - ⑤ Button Head Hex Screw 1/4"-20 x 5/8" (4)
 - ⑥ Lock Nut 1/4"-20 (4)

14. Install the Tapered Handles with Black Nylon Washers to the Short Guide Blocks with Hex Head Bolt. Attach the Router Plate Hangers with two Button Head Hex Screws and two Lock Nuts. **Figure 11.**

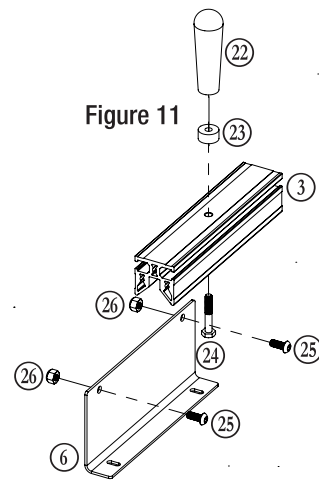

15. Repeat this process for the other side.

VIII. AT THIS POINT YOU WILL NEED:

- ⑤ Router Plate (1)
- **Hardware Bag H**
 - ⑦ Pan Head Screw 10-32 x 3/8"; black (4)
 - ⑦B #10 Washers SAE (4)

16. Attach the Router Plate to the Router Plate Hangers using four Pan Head Screws and #10 Washers finger-tight only at this point. **Figure 12.**

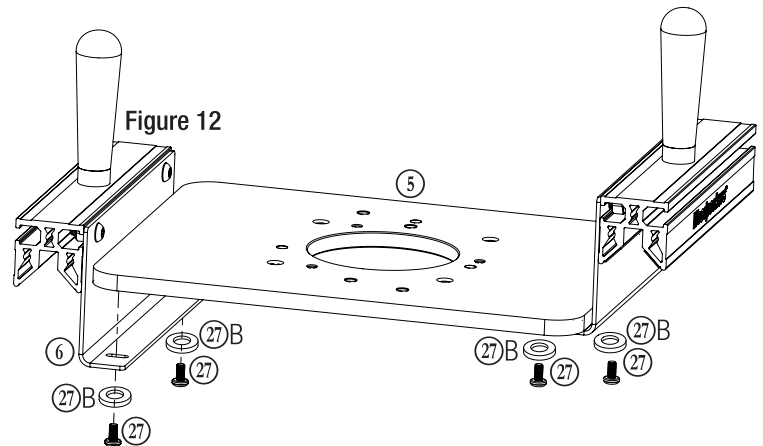

17. Set the Router Base Assembly on the Carriage Assembly and slide the Carriage Assembly over the edge of your work surface to gain access to the Pan Head Screws attaching the Router Plate to the Router Plate Hangers. **Figure 13.**

18. Use light-duty "F" style clamps with plastic or wood clamping pads (Not Included) to GENTLY clamp the Router Base Assembly to the Carriage Assembly. **Figure 13 "X"**.

19. Inspect and adjust the Router Plate to be centered between and parallel with the Router Plate Hangers. Tighten the four Pan Head Screws.

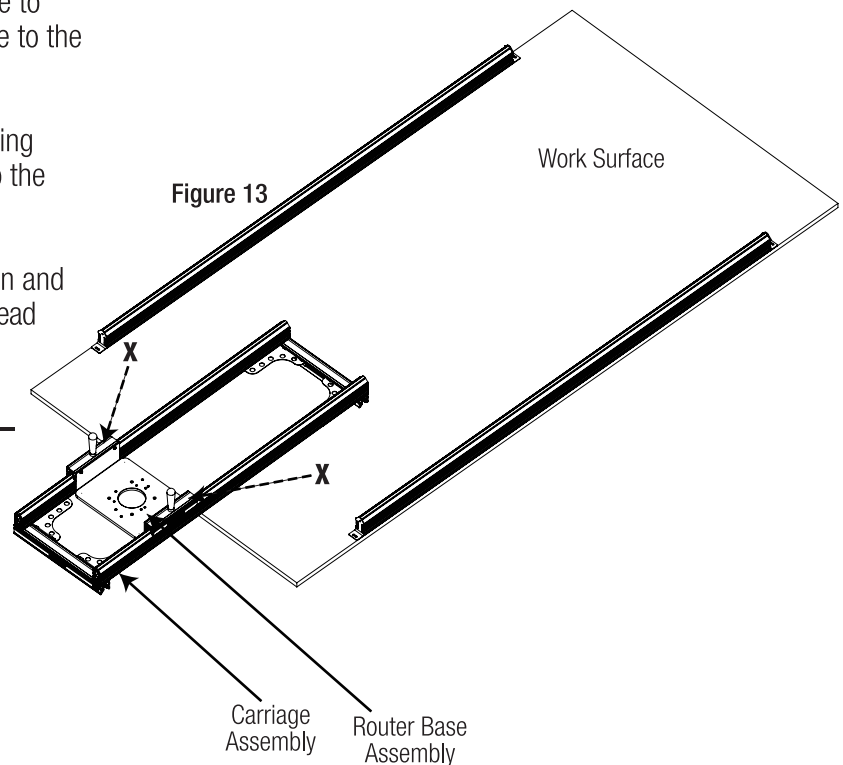

IX. AT THIS POINT YOU WILL NEED:

- ⑦ V-Rail End Cap (4)
- ⑨ Guide Block End Cap (8)
- **HARDWARE BAG D**
- ⑳ Thread Forming Screw Pan Head 10-32 x 1/2 (28)

20. Install the four V-Rail End Caps to the four ends of the two Short V-Rails using twelve Thread Forming Screws. **Figure 14.** Use a handheld screwdriver to install the thread forming screws.

NOTE: It is very easy to strip out the aluminum extrusion if you use a power driver.

21. Install the eight Guide Block End Caps to the eight ends of the Guide Blocks using sixteen Thread Forming Screws. **Figure 14.** Use a handheld screwdriver to install the thread forming screws.

NOTE: It is very easy to strip out the aluminum extrusion if you use a power driver.

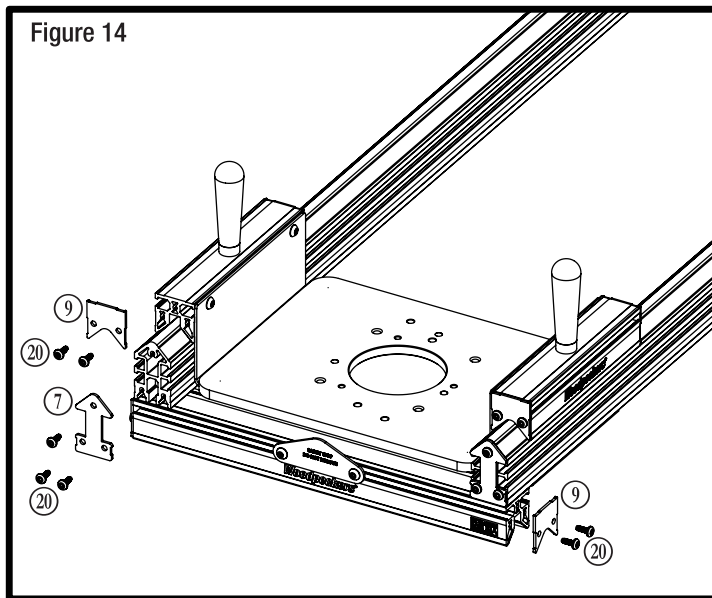

X. AT THIS POINT YOU WILL NEED:

- **HARDWARE BAG I**
- Assorted Router Screws

22. From the chart below, **Figure 15**, select the screws and hole pattern which matches your router. Remove the screws and the face plate from your router. (Festool 1400 – leave faceplate on!) Use the Router Screws provided to attach your router to the Router Plate ensuring that the handles on your router do not interfere with your grip on the Router Sled Handles.

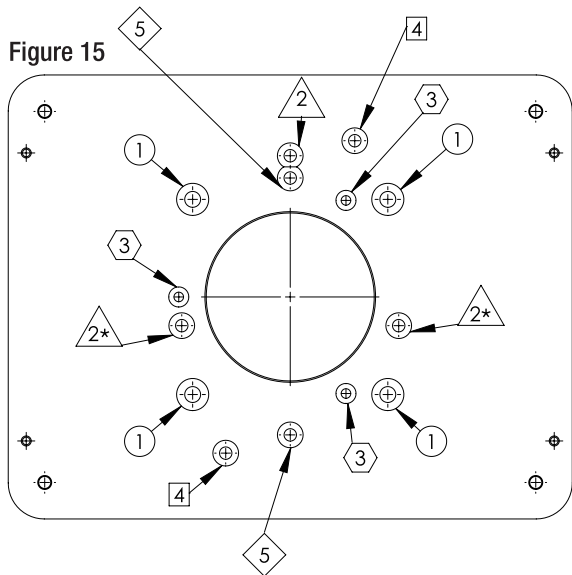

Compatible Router	Hole #	Screws	Qty
Porter Cable 7518/7519/7539	1	5/16-18	4
Porter Cable 890	3	10-24	3
Festool 2200	4	M6 X 1.00	2
Festool 1400	5	M6 X 1.00	2
Triton TRA001	1	1/4-20	4
Triton MOF001	1	1/4-20	4
BOSCH 1617EVS (FIXED BASE ONLY)	3	10-24	3
BOSCH MRC23EVSK	3	M4 X 0.7	3
Milwaukee 5625	1	5/16-18	4
Milwaukee 5616	3	10-24	3
DeWalt 618B3	3	8-32	3
DeWalt 625/621	2	M6 X 1.00	3/2*
Makita RF1101	3	10-24	3

Hardware Bag I - Router Screws

DESCRIPTION	QTY.
5/16"-18	4
1/4"-20	4
10-24	3
8-32	3
M6 x 1.00"	3
M4 x 0.7"	3

USING YOUR SLAB FLATTENING MILL

1. Remove the Router Base and Carriage Assembly.
2. Position your slab roughly centered between the Long V-Rails and no closer than 7" from the ends. Typically, start by cutting what will be the bottom of the finished slab first.
3. Replace the Carriage Assembly and Router Base.
4. Use the Router Base as a reference point to locate the high and low points on the slab. Shim the slab to eliminate rocking and to level out crowns and twists. There is some "art" involved in this step. Try to shim and brace the slab to maximize the finished thickness and minimize the amount of cutting you must do. When the slab is properly adjusted and stable, install the Slab Clamping Dogs (30). Put one screw behind the Slab Clamping Dog to position it, then a second through it to lock the slab in place.

Figure 17. Make sure the ends of the Slab Clamping Dogs are well below the cutting plane of the router bit.

5. We recommend a "spoilboard" style router bit. Follow the router bit manufacturer's recommendations for router speed and depth of cut.
6. Set your router bit on the highest point in the slab. Adjust the depth of cut to remove a conservative amount from that point. It's a good idea to take a light cut and traverse the entire slab carefully to ensure you correctly identified to highest point.
7. Typically work from right to left, taking approximately one half the router bit width per pass, pushing the router across and back, then stepping to the left again.

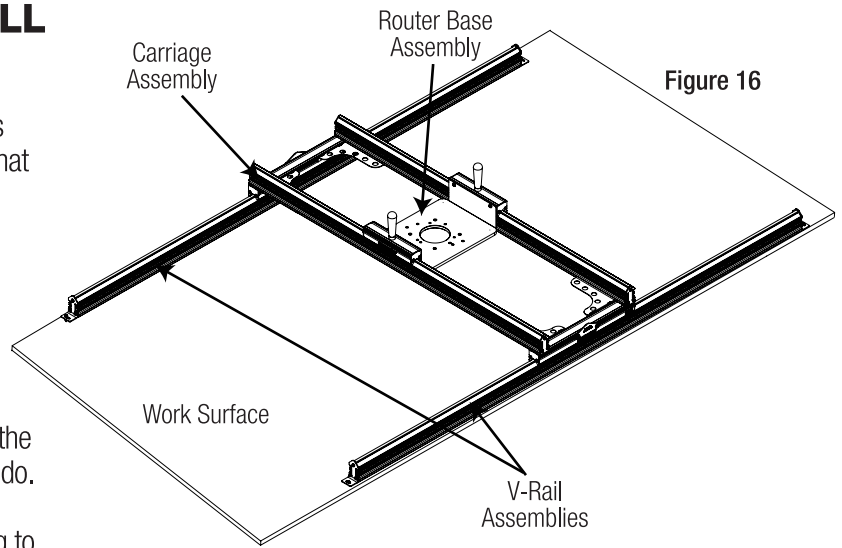

Figure 16

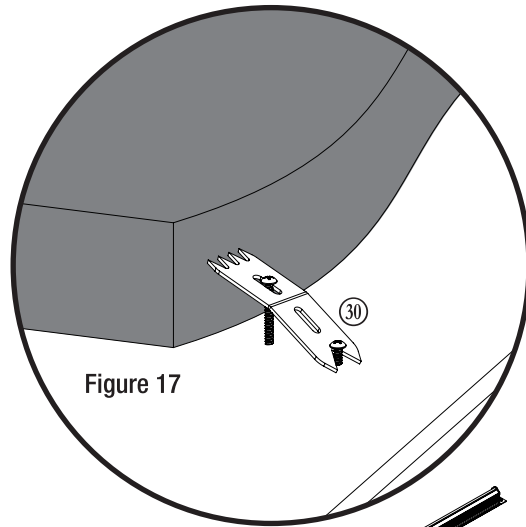

Figure 17

NARROWER SLABS *OPTIONAL*

When working on narrow slabs, you may want to move one of the Long V-Rails closer. Use the same gauge block procedure outlined previously (See Steps 12-14, Page 4). Once the Long V-Rails are parallel and screwed down, unlock the six machine screws (See Figure 3, Page 3) that secure the end of the Carriage Assembly and slide it in. Position both ends of the Carriage Assembly on the Long V-Rails, making sure the Long guide blocks are resting completely on the Long V-Rails, then tighten the machine screws.

LONGER OR WIDER SLABS *OPTIONAL*

The Long V-Rails can be repositioned down the length of a longer slab. Alternatively, you can extend the Long V-Rails with another pair of V-Rails and the V-Rail Connectors (29). **Use the connectors to extend the length of the main V-Rails only!** You can use the Long V-Rails in the Extension Kit to replace the Short V-Rails in the Carriage Assembly, but, **do not use connected V-rails in the Carriage Assembly.**

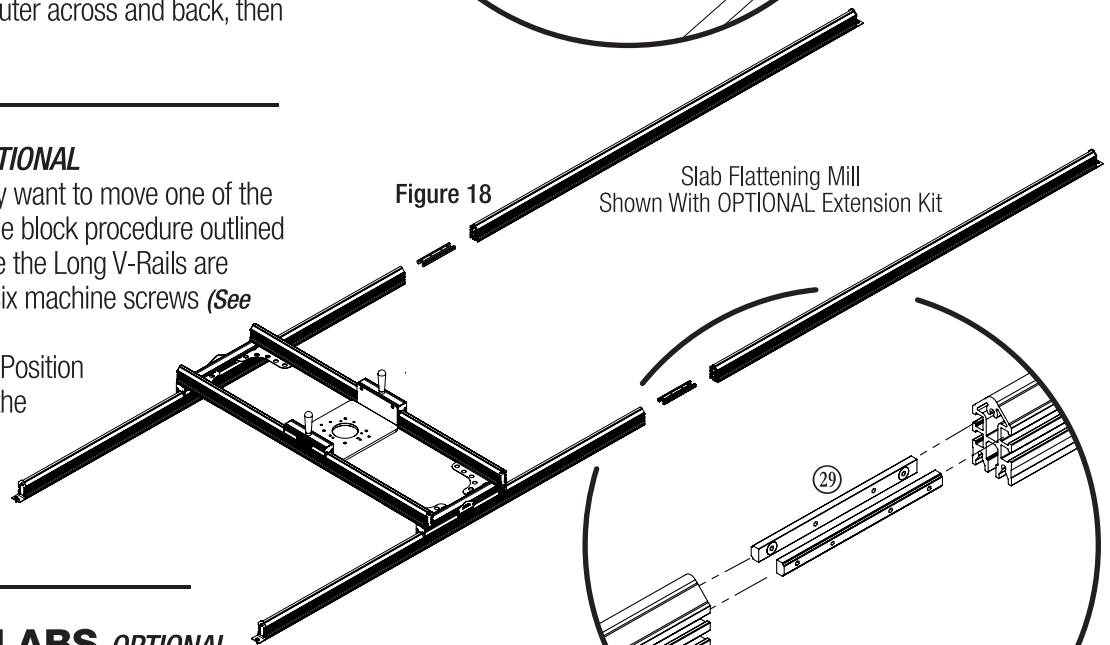

Figure 18

Slab Flattening Mill
Shown With OPTIONAL Extension Kit

Figure 18-A

Woodpeckers®

Woodpeckers, LLC Strongsville, Ohio

woodpeck.com

© 2022 Woodpeckers, LLC



woodpeck.com

At Woodpeckers we are constantly reviewing & improving our tools. The most current version of our instruction manuals are always available to download at **woodpeck.com.**

(Located in the bottom section of the tool's page under the "Additional Information" or "Instructions" tabs.)



Be the first to know all the new products, *OneTIME Tools* & sales by subscribing to our eClub. *(Located at the top center of our webpage woodpeck.com.)*



YouTube

Subscribe to our YouTube channel to stay up-to-date on all the latest tool tips & tricks.



INTERACT WITH US! Follow us on Facebook, Instagram & TikTok!



Enjoy shop tips, project ideas, tool techniques & more in our Woodworking Resource Center/Blog. *(Located at the bottom center of our webpage woodpeck.com.)*



WARNING!

This product can expose you to chemicals, including chromium, which is known to the State of California to cause cancer and birth defects or other reproductive harm.

For more information go to www.P65Warnings.ca.gov