

Woodpeckers®

SPLINE JIG

OWNER'S MANUAL

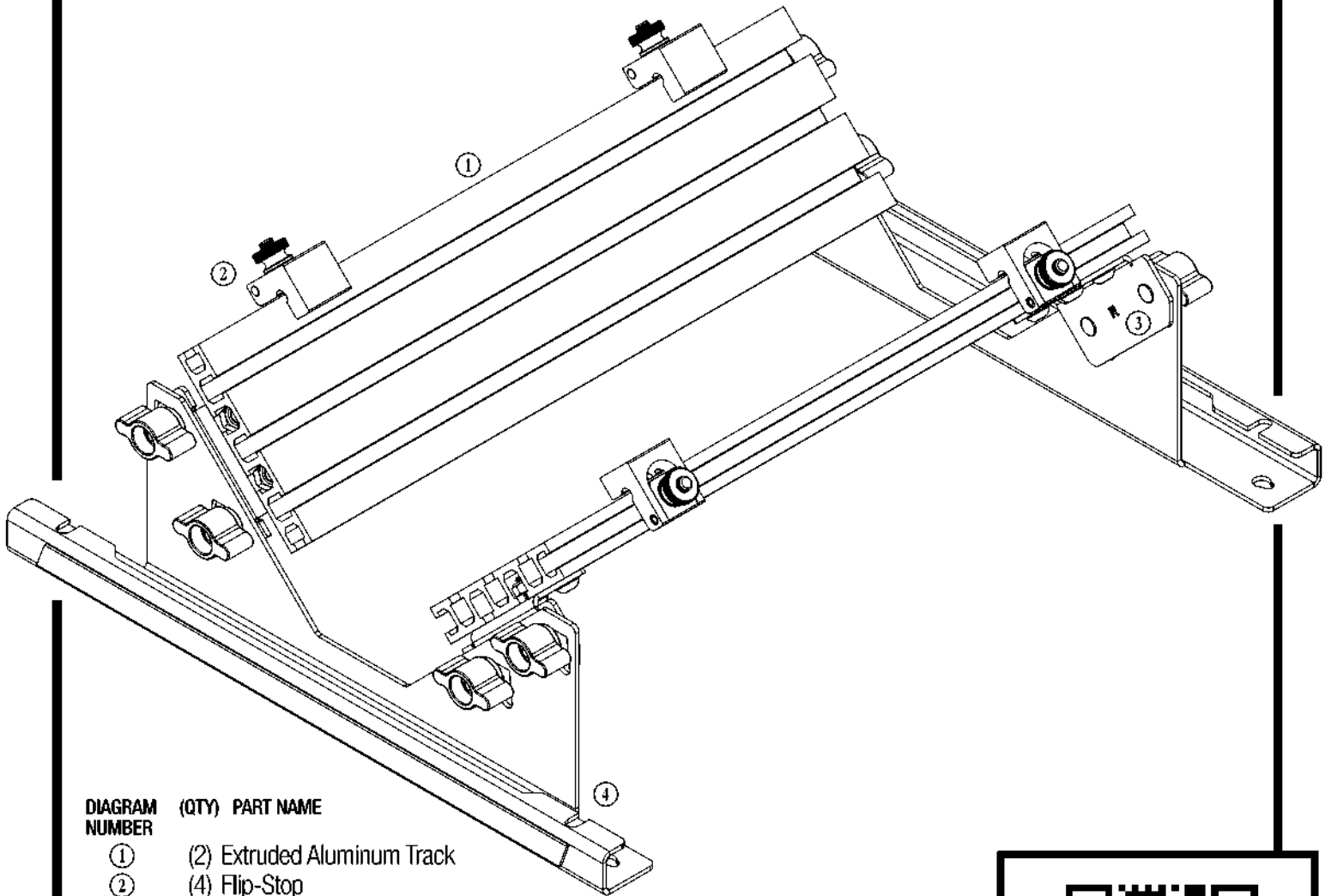

DIAGRAM NUMBER (QTY) PART NAME

- ① (2) Extruded Aluminum Track
- ② (4) Flip-Stop
- ③ (4) Angle Bracket
- ④ (2) Leg

HARDWARE BAG A

- (4) Self-Adhesive Glide Strip
- (8) Lock Knob
- (16) 1/4" - 20 x 5/8" Button Head Cap Screw
- (16) 1/4" - 20 Hex Nut



Scan the QR code above to watch the video or visit woodpeck.com under the video tab towards the bottom of the product page.

If you think you're missing anything, email us at rma.lroom@woodpeck.com.
You can also call us at 800-752-0725 from 9:00 a.m. to 4:00 p.m. EST Monday - Friday.

ASSEMBLY

1. Place a 1/4"-20 x 5/8" Button-Head Cap Screw in each of the 4 holes in the 4 Angle Brackets ③. The heads of the Cap Screws should be on the same side as the bent flange. Start a 1/4"-20 Hex Nut on each Cap Screw.

Figure A

2. Slide the Angle Brackets onto the Extruded Aluminum Tracks ①, placing the Hex Nuts into the tracks. The brackets align with the chamfered end of the flange facing up and the flange on the outside of the track. Snug, but do not tighten, the Button-Head Cap screws. **Figure B**

3. Stand one of the Tracks on end on a flat reference surface (your table saw top, for instance) with the studs of the angle brackets hanging just off the edge. Tighten the Button-Head Cap Screws, locking the Angle Brackets to the track. Repeat for both ends of both tracks. **Figure C**

4. Slide the studs on the Angle Brackets through the outside slots in the ④ Legs and install 1/4"-20 Lock Knobs on each. **Figure D**

5. Rest a square between the 2 tracks and confirm that it rests solidly on both track surfaces. Make any slight adjustments needed and lock the Knobs securing the Tracks to the Legs.

6. Install the Self-Adhesive Glide Strips onto the bottom and sides of both legs. Ensure the strips do not overhang edges of the Legs. **Figure E**

7. Install the ② Flip-Stops into the top edge of the tracks. **Figure G**

FIGURE A

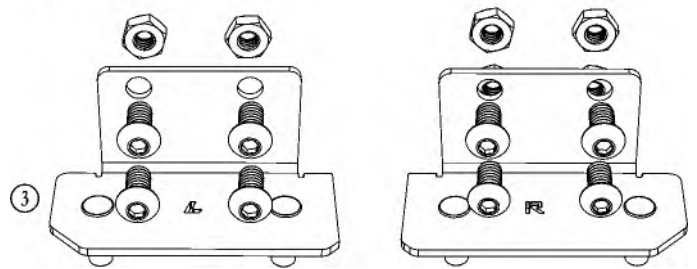

FIGURE B

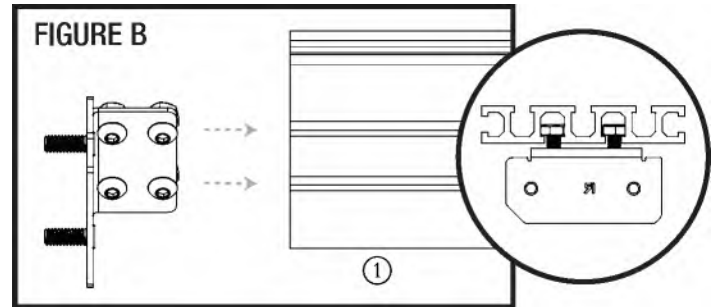

FIGURE C

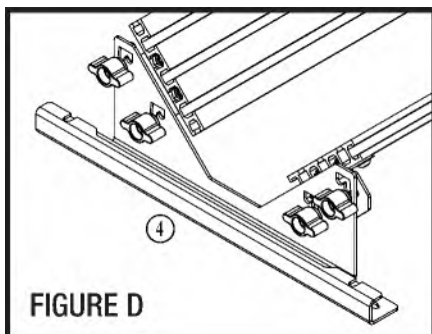
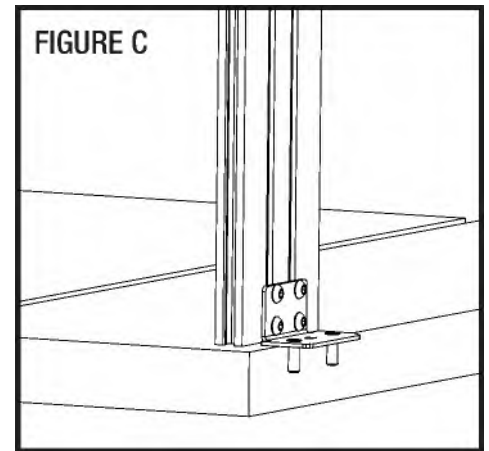

FIGURE D

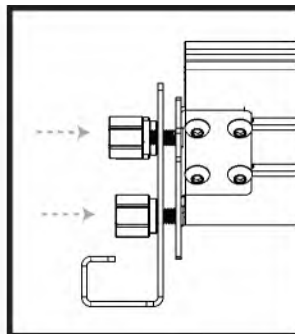

FIGURE E

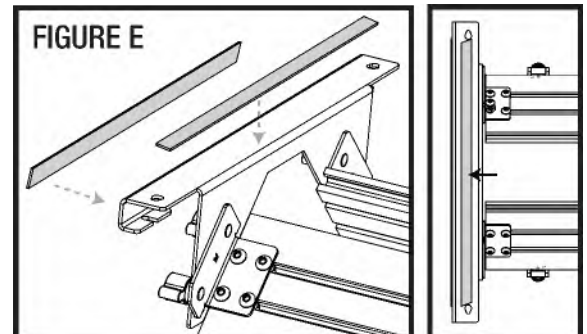
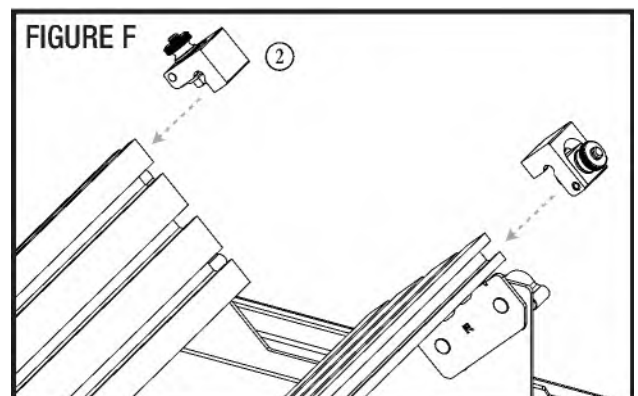

FIGURE F



USING YOUR SPLINE JIG

1. To use the laser-engraved scales, adjust your rip fence so that the "0" mark of the scales aligns with the center of your saw blade or router bit. Now you can set the location of the spline grooves using the scale and the flip-stops. **Figure G**

Alternatively, you can position the spline grooves by adjusting your rip fence. The method you choose depends on the accuracy of your saw and the ease of adjusting the rip fence. If it is difficult to align and lock consistently, keeping the fence fixed and moving the stops works best. If you have a fence that adjusts reliably and locks easily, you may find it easier to make adjustments using the fence.

2. To set the depth of cut, place your mitered corner in the jig and adjust your machine fence so the joint is just to the side of your saw blade or router bit. Adjust the machine depth of cut to give you the desired depth for your spline. $\frac{2}{3}$ the thickness of the joint is a good starting point. You can adjust up or down to get the aesthetic look you want. **Figure H**

3. While cutting, apply pressure to keep the jig firmly against the rip fence as you push through the cutting tool. You may find it helpful to use a hold-down clamp in the track to secure the workpiece... particularly when working on a router table. **Figure I**

4. You will likely use the Spline Jig most of the time with the tracks in the wide setting. This holds your mitered corner just off the surface of the machine table. **Figure J**

5. If you have a project longer than 16", moving the tracks to the narrow setting raises the mitered corner above the Legs, allowing the project to extend outside the Spline Jig. **Figure K**

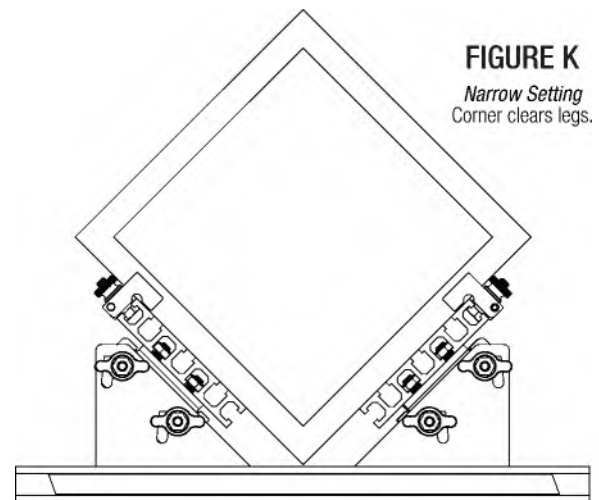
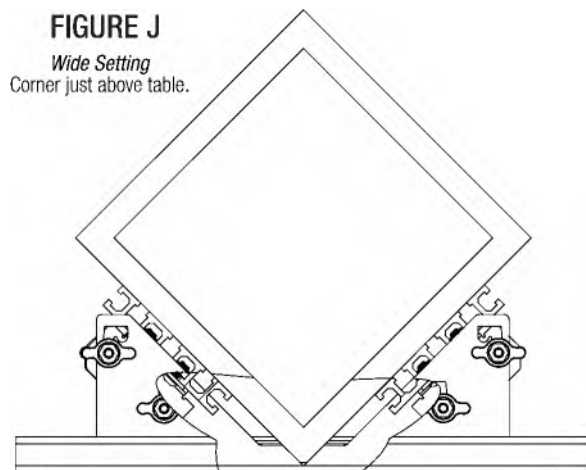
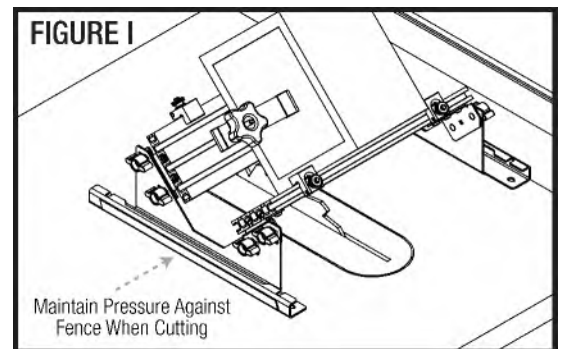
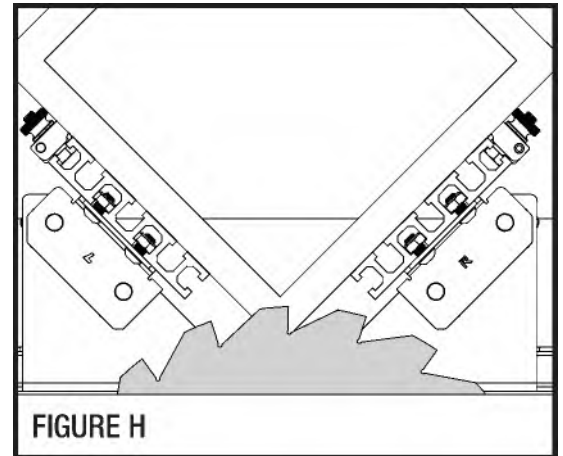
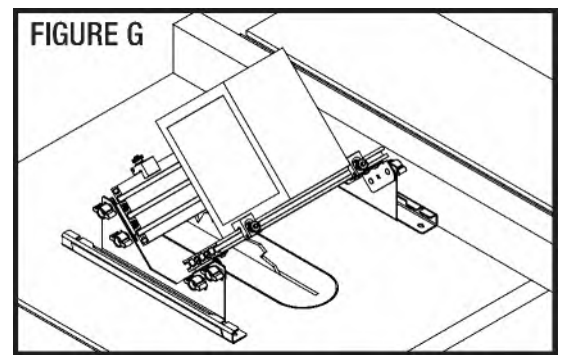

Woodpeckers®

Woodpeckers, LLC Strongsville, Ohio

woodpeck.com

© 2023 Woodpeckers, LLC



woodpeck.com

At Woodpeckers we are constantly reviewing & improving our tools. The most current version of our instruction manuals are always available to download at woodpeck.com.

(Located in the bottom section of the tool's page under the "Additional Information" or "Instructions" tabs.)



Be the first to know all the new products, OneTIME Tools & sales by subscribing to our eClub. *(Located at the top center of our webpage woodpeck.com.)*



Subscribe to our YouTube channel to stay up-to-date on all the latest tool tips & tricks.



INTERACT WITH US! Follow us on Facebook, Instagram & TikTok!



Enjoy shop tips, project ideas, tool techniques & more in our Woodworking Resource Center/Blog. *(Located at the bottom center of our webpage woodpeck.com.)*



WARNING!

This product can expose you to chemicals, including chromium, which is known to the State of California to cause cancer and birth defects or other reproductive harm.

For more information go to www.P65Warnings.ca.gov